

olivetti

d-Copia 3501 / 3501MF **d-Copia 4501 / 4501MF**

Operation Manual

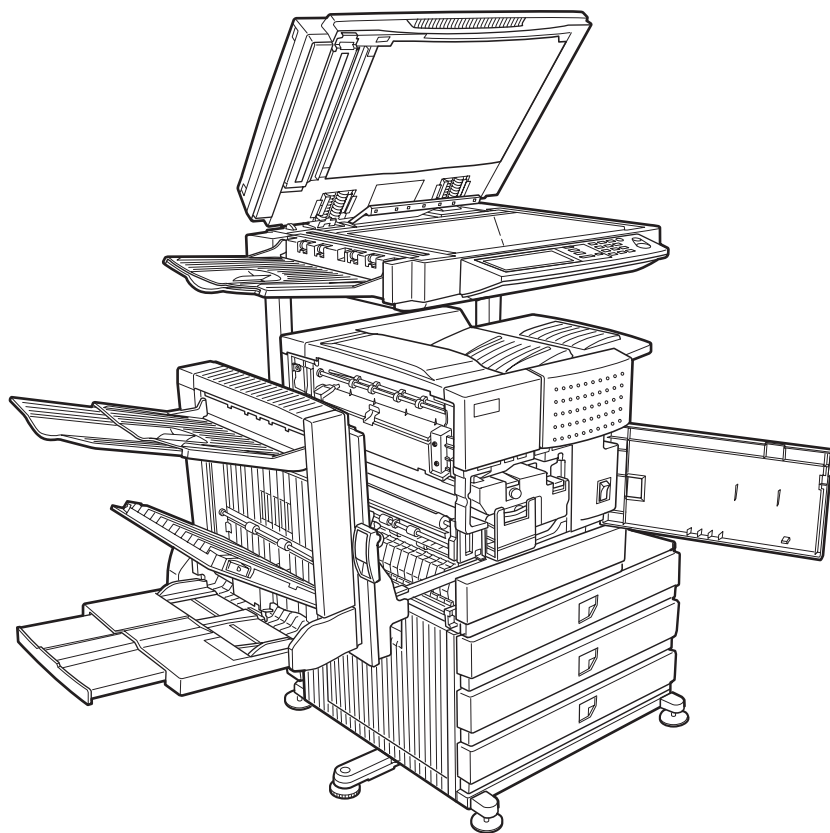

Be sure to become thoroughly familiar with this manual to gain the maximum benefit from the product. **Before installing this product, be sure to read the installation requirements and cautions sections.**

Be sure to keep all operation manuals handy for reference including this manual, the "Operation manual (for general information and copier operation)" and operation manuals for any optional equipment which has been installed.

PUBLICATION ISSUED BY:

Olivetti S.p.A.

Gruppo Telecom Italia

Via Jervis, 77 - 10015 Ivrea (ITALY)

www.olivetti.com

Copyright © 2006, Olivetti

All rights reserved

The  mark affixed to the product certifies that the product satisfies the basic quality requirements.



The manufacturer reserves the right to carry out modifications to the product described in this manual at any time and without any notice.



ENERGY STAR is a U.S. registered mark.

The ENERGY STAR program is an energy reduction plan introduced by the United States Environmental Protection Agency in response to environmental issues and for the purpose of advancing the development and utilization of more energy efficient office equipment.

Your attention is drawn to the following actions which could compromise the conformity attested to above, as well as the characteristics of the product:

- incorrect electrical power supply;
 - incorrect installation, incorrect or improper use or use not in compliance with the warnings provided in the User's Manual supplied with the product;
 - replacement of original components or accessories with others of a type not approved by the manufacturer, or performed by unauthorised personnel.
-

All rights reserved. No part of this material may be reproduced or transmitted in any form or by any means, electronic or mechanical, including photocopying, recording or by any information storage and retrieval system, without permission in writing from the Publisher.

In some areas, the "POWER" switch positions are marked "I" and "⏻" on the copier instead of "ON" and "OFF".

The symbol "⏻" denotes the copier is not completely de-energized but in a stand-by condition at this "POWER" switch position.

If your copier is so marked, please read "I" for "ON" and "⏻" for "OFF".

Caution!

For a complete electrical disconnection, pull out the main plug.



The socket-outlet shall be installed near the equipment and shall be easily accessible.

Required in IEC-950 (EN 60 950) - Europe

- The equipment should be installed near an accessible socket outlet for easy disconnection.

Required in Appendix ZB of BS 7002 (En 60 950) — United Kingdom

MAINS PLUG WIRING INSTRUCTIONS

The mains lead of this equipment is already fitted with a mains plug which is either a non-rewireable (moulded) or a rewireable type. Should the fuse need to be replaced, a BSI or ASTA approved fuse to BS1362 marked  or  and of the same rating as the one removed from the plug must be used.

Always refit the fuse cover after replacing the fuse on the moulded plug. Never use the plug without the fuse cover fitted.

In the unlikely event of the socket outlet in your home not being compatible with the plug supplied either cut-off the moulded plug (if this type is fitted) or remove by undoing the screws if a rewireable plug is fitted and fit an appropriate type observing the wiring code below.

DANGER: The fuse should be removed from the cut-off plug and the plug destroyed immediately and disposed of in a safe manner. Under no circumstances should the cut-off plug be inserted elsewhere into a 13A socket outlet as a serious electric shock may occur.

To fit an appropriate plug to the mains lead, follow the instructions below:

IMPORTANT: The wires in this mains lead are coloured in accordance with the following code:

GREEN-AND-YELLOW:	Earth
BLUE:	Neutral
BROWN:	Live

As the colours of the wires in this mains lead may not correspond with coloured markings identifying the terminals in your plug, proceed as follows:

The wire which is coloured **GREEN-AND YELLOW** must be connected to the terminal in the plug which is marked with the letter **E**, or by the safety earth symbol  , or coloured green or green-and-yellow.

The wire which is coloured **BLUE** must be connected to the terminal which is marked with the letter **N** or coloured black.

The wire which is coloured **BROWN** must be connected to the terminal which is marked with the letter **L** or coloured red.

If you have any doubt, consult a qualified electrician.

WARNING: THIS APPARATUS MUST BE EARTHED.

Warning:

This is a Class A product. In a domestic environment this product may cause radio interference in which case the user may be required to take adequate measures.

Warranty

While every effort has been made to make this document as accurate and helpful as possible, Olivetti S.p.A. makes no warranty of any kind with regard to its content. All information included herein is subject to change without notice. Olivetti is not responsible for any loss or damages, direct or indirect, arising from or related to the use of this operation manual. © Copyright Olivetti S.p.A. 2006. All rights reserved. Reproduction, adaptation or translation without prior written permission is prohibited, except as allowed under copyright laws.

DIRECTIVE 2002/96/CE ON THE TREATMENT, COLLECTION, RECYCLING AND DISPOSAL OF ELECTRIC AND ELECTRONIC DEVICES AND THEIR COMPONENTS

INFORMATION

1. FOR COUNTRIES IN THE EUROPEAN UNION (EU)

The disposal of electric and electronic devices as solid urban waste is strictly prohibited: it must be collected separately.

The dumping of these devices at unequipped and unauthorized places may have hazardous effects on health and the environment.

Offenders will be subjected to the penalties and measures laid down by the law.

TO DISPOSE OF OUR DEVICES CORRECTLY:

- a) Contact the Local Authorities, who will give you the practical information you need and the instructions for handling the waste correctly, for example: location and times of the waste collection centres, etc.
- b) When you purchase a new device of ours, give a used device similar to the one purchased to our dealer for disposal.



The crossed dustbin symbol on the device means that:

- when it to be disposed of, the device is to be taken to the equipped waste collection centres and is to be handled separately from urban waste;
- The producer guarantees the activation of the treatment, collection, recycling and disposal procedures in accordance with Directive 2002/96/CE (and subsequent amendments).

2. FOR OTHER COUNTRIES (NOT IN THE EU)

The treatment, collection, recycling and disposal of electric and electronic devices will be carried out in accordance with the laws in force in the country in question.

Part 1: General Information

NOTES

- Considerable care has been taken in preparing this manual. If you have any comments or concerns about the manual, please contact your nearest Olivetti Service Department.
- This product has undergone strict quality control and inspection procedures. In the unlikely event that a defect or other problem is discovered, please contact your dealer or nearest Olivetti Service Department.
- Aside from instances provided for by law, Olivetti is not responsible for failures occurring during use of the product or its options, or failures due to incorrect operation of the product and its options, or other failures, or for any damage that occurs due to use of the product.

The display screens, messages, and key names shown in the manual may differ from those on the actual machine due to product improvements and modifications.

PRODUCT CONFIGURATIONS

The table below shows the product models covered by this manual.

(As of March 2006)

Model	Product configuration
Olivetti d-Copia 3501/d-Copia 3501MF	Laser printer
Olivetti d-Copia 4501/d-Copia 4501MF	Laser printer

OPERATION MANUALS

The following operation manuals are provided for the machine. Please read the appropriate manuals as needed for the features you wish to learn about.

- Operation manual (for general information and copier operation) (this manual):
The first half of this manual provides general information about the machine, including safety information, loading paper, removing misfeeds, and regular maintenance.
The second half of the manual explains how to use the copy and document filing functions.
 - Key operator's guide:
This primarily explains key operator programs for machine management and copier related functions. Key operator programs for the fax, printer and network scanner functions are explained in the manuals for those functions.
Key operator programs are used by key operators to configure function settings to meet the needs of the customer.
 - Operation manual (for facsimile)
This manual explains the procedures for using the machine as a facsimile. To use the fax function, the facsimile expansion kit must be installed.
 - Software setup guide (for printer)
This explains how to connect the machine to your computer, install the printer driver for Windows, and configure the printer driver settings.
 - Operation manual (for printer)*
This manual explains the procedures for using the machine as a printer.
 - Operation manual (for network scanner)*
This manual explains the procedures for using the machine as a network scanner when connected to a computer. To use the network scanner function, the NS3 network scanner expansion kit must be installed.
- * The operation manual (for printer) and the operation manual (for network scanner) are provided as PDF files in the CD-ROM.

This manual is not provided as printed manual.

INSTALLATION REQUIREMENTS

Improper installation may damage this product. Please note the following during initial installation and whenever the machine is moved.

1. The machine should be installed near an accessible power outlet for easy connection.



2. Be sure to connect the power cord only to a power outlet that meets the specified voltage and current requirements. Also make certain the outlet is properly grounded.

● For the power supply requirements, see the name plate on the back of the main unit.

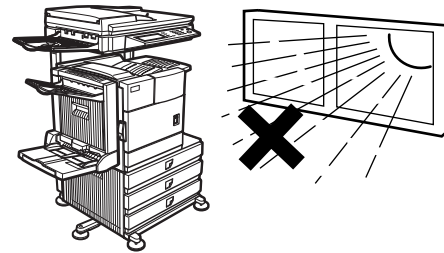

3. Do not install your machine in areas that are:

- damp, humid, or very dusty
- exposed to direct sunlight
- poorly ventilated
- subject to extreme temperature or humidity changes, e.g., near an air conditioner or heater.

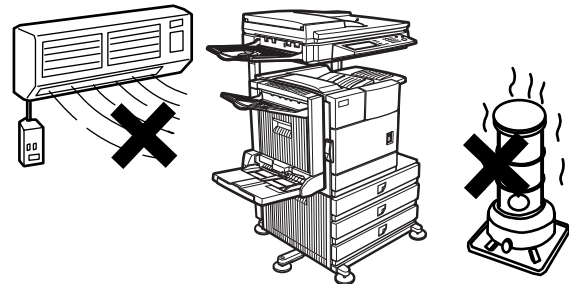
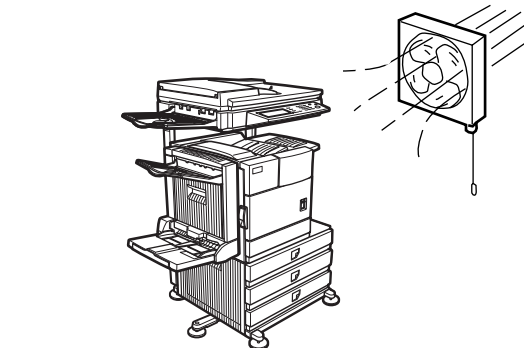

4. Be sure to allow the required space around the machine for servicing and proper ventilation.

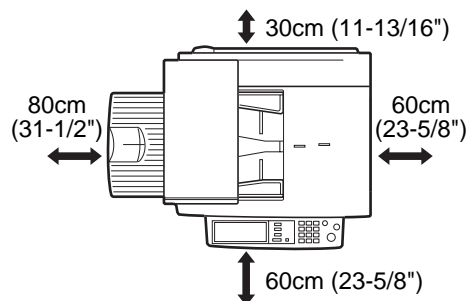

A small amount of ozone is produced within the machine during operation. The emission level is insufficient to cause any health hazard.

NOTE:

The present recommended long term exposure limit for ozone is 0.1 ppm (0.2 mg/m³) calculated as an 8 hr. time-weighted average concentration.

However, since the small amount that is emitted may have an objectionable odor, it is advisable to place the copier in a ventilated area.

CAUTIONS

1. Do not touch the photoconductive drum. Scratches or smudges on the drum will cause dirty prints.
2. The fusing unit is extremely hot. Exercise care in this area.
3. Do not look directly at the light source. Doing so may damage your eyes.
4. Five adjusters are provided on all optional stand/paper drawer units. These adjusters should be lowered until they contact the floor. When moving the machine with the optional stand/paper drawer, be sure to raise the adjusters. Also, unlock the two casters at the front of the optional stand/paper drawer. After moving the machine, lower the four adjusters until they reach the floor and lock the two casters.
5. Do not make any modifications to this machine. Doing so may result in personal injury or damage to the machine.
6. Since this machine is heavy, it is recommended that it be moved by more than one person to prevent injury.
7. When connecting this machine to a computer, be sure to first turn both the computer and the machine off.
8. Do not make copies of anything which is prohibited from copying by law. The following items are normally prohibited from printing by national law. Other items may be prohibited by local law.
 - Money • Stamps • Bonds • Stocks
 - Bank drafts • Checks • Passports • Driver's licences

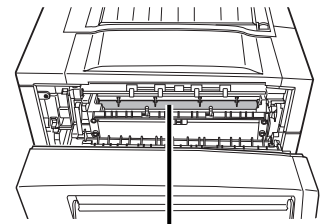

Fusing unit

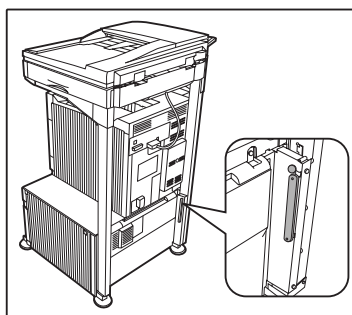
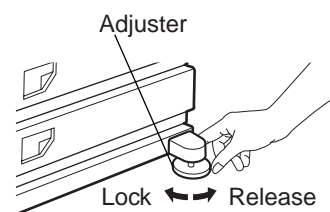
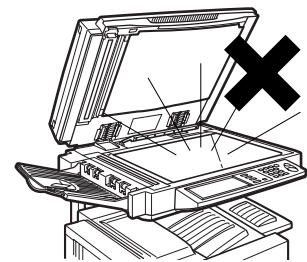

The part indicated in the illustration is only to be handled by a service technician. Absolutely do not touch this part.

Some models include the document filling function, which stores document image on the machine's hard disk. Stored documents can be called up and printed or transmitted as needed. If a hard disk failure occurs, it will no longer be possible to call up the stored document data. To prevent the loss of important documents in the unlikely event of a hard disk failure, keep the originals of important documents or store the original data elsewhere. With the exception of instances provided for by law, Olivetti S.p.A.: bears no responsibility for any damages or loss due to the loss of stored document data.

"BATTERY DISPOSAL"

THIS PRODUCT CONTAINS A LITHIUM PRIMARY MEMORY BACK-UP BATTERY THAT MUST BE DISPOSED OF PROPERLY. PLEASE CONTACT YOUR LOCAL OLIVETTI DEALER OR AUTHORISED SERVICE REPRESENTATIVE FOR ASSISTANCE IN DISPOSING OF THIS BATTERY.

This product utilizes tin-lead solder, and a fluorescent lamp containing a small amount of mercury. Disposal of these materials may be regulated due to environmental considerations.

For disposal or recycling information, please contact your local authorities or the Electronics Industries Alliance: www.eia.org

Laser Information

Wave length	785 nm +10 nm -15 nm
Pulse times	North America: 35 cpm model: (4.1 μs ± 4.1 ns)/7 mm 45 cpm model: (5.7 μs ± 5.7 ns)/7 mm Europe: 35 cpm model: (3.8 μs ± 3.8 ns)/7 mm 45 cpm model: (4.4 μs ± 4.4 ns)/7 mm
Output power	0.2 mW - 0.4 mW

At the production line, the output power of the scanner unit is adjusted to 0.4 MILLIWATT PLUS 8 % and is maintained constant by the operation of the Automatic Power Control (APC).

Caution

Use of controls or adjustments or performance of procedures other than those specified herein may result in hazardous radiation exposure.

For North America:

SAFETY PRECAUTIONS

This Digital Equipment is rated Class 1 and complies with 21 CFR 1040.10 and 1040.11 of the CDRH standards. This means that the equipment does not produce hazardous laser radiation. For your safety, observe the precautions below.

- Do not remove the cabinet, operation panel or any other covers.
- The equipment's exterior covers contain several safety interlock switches. Do not bypass any safety interlock by inserting wedges or other items into switch slots.

For Europe:

CLASS 1 LASER PRODUCT

LASER KLASSE 1

LUOKAN 1 LASERLAITE

KLASS 1 LASERAPPARAT

CAUTION
INVISIBLE LASER RADIATION
WHEN OPEN INTERLOCKS
DEFEATED. AVOID EXPOSURE
TO BEAM.

VORSICHT
UNSICHTBARE
LASERSTRAHLUNG WENN
ABDECKUNG GEÖFFNET UND
SICHERHEITSVERRIEGELUNG
ÜBERBRÜCKT. NICHT DEM
STRAHL AUSSETZEN.

ADVARSSEL
USYNLIG LASERSTRÅLNING
VED ÅBNING, NÅR
SIKKERHEDSBRYDERE ER
UDE AF FUNKTION. UNDGÅ
UDSAETTELSE FOR
STRÅLNING.

VAROITUS!
LAITTEEN KÄYTTÄMINEN
MUULLA KUIN TÄSSÄ
KÄYTTÖOHJEESSA
MAINITULLA TAVALLA SAATTAA
ALTISTAA KÄYTTÄJÄN
TURVALLISUUSLUOKAN 1
YLITTÄVÄLLE
NÄKYMÄTTÖMÄLLE
LASERSÄTEILYLLE.

VARNING
OM APPARATEN ANVÄNDS PÅ
ANNAT SÄTT ÄN I DENNA
BRUKSANVISNING
SPECIFICERATS, KAN
ANVÄNDAREN UTSÄTTAS FÖR
OSYNLIG LASERSTRÅLNING,
SOM ÖVERSKRIDER GRÄNSEN
FÖR LASERKLASS 1.

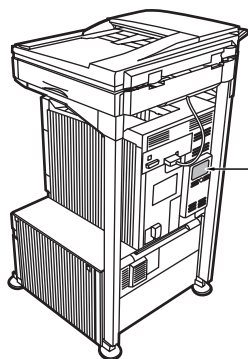

CLASS 1
LASER PRODUCT

LASER KLASSE 1

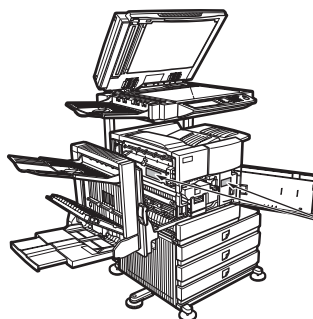



CAUTION INVISIBLE LASER RADIATION WHEN OPEN AND INTERLOCKS DEFEATED
OR EXPOSURE TO BEAM.
VORSICHT UNSICHTBARE LASERSTRAHLUNG WENN ABDECKUNG GEÖFFNET UND
SICHERHEITSVERRIEGELUNG ÜBERBRÜCKT. NICHT DEM STRAHL AUSSETZEN.
ADVARSSEL USYNLIG LASERSTRÅLNING VED ÅBNING, NÅR SIKKERHEDSBRYDERE ER
UDE AF FUNKTION. UNDGÅ UDSÆTTELSE FOR STRÅLNING.
VAROITUS! LAITTEEN KÄYTTÄMINEN MUULLA KUIN TÄSSÄ KÄYTTÖOHJEESSA
MAINITULLA TAVALLA SAATTAA ALTISTAA KÄYTTÄJÄN TURVALLISUUSLUOKAN 1
YLITTÄVÄLLE NÄKYMÄTTÖMÄLLE LASERSÄTEILYLLE.
VARNING OM APPARATEN ANVÄNDS PÅ ANNAT SÄTT ÄN I DENNA BRUKSANVISNING
SPECIFICERATS, KAN ANVÄNDAREN UTSÄTTAS FÖR OSYNLIG LASERSTRÅLNING,
SOM ÖVERSKRIDER GRÄNSEN FÖR LASERKLASS 1.

△ 注意 (サービスマン用)

カバーを開けてかつインターロックを無効にした場合にはレーザー光にさらされないようにしてください。

CONTENTS

	Page
PRODUCT CONFIGURATIONS	0-1
OPERATION MANUALS	0-1
INSTALLATION REQUIREMENTS	0-2
CAUTIONS	0-3
● Laser Information	0-4
CONTENTS	0-5

CHAPTER 1 BEFORE USING THE PRODUCT

INTRODUCTION	1-2
MAIN FEATURES	1-3
PART NAMES AND FUNCTIONS	1-9
● Exterior	1-9
● Interior	1-10
● Part names and functions of peripheral devices ..	1-11
● Operation panel	1-13
● Touch panel	1-14
TURNING THE POWER ON AND OFF	1-17
AUDITING MODE	1-18
● Using the machine when the auditing mode is enabled	1-18

CHAPTER 2 MANAGING THE MACHINE

LOADING PAPER	2-2
● Loading paper in paper tray 1	2-2
● Changing the paper size in paper tray 1	2-2
● Specifications of paper trays	2-3
● Setting the paper type and paper size	2-5
● Setting the paper size when a special size is loaded	2-6
● Programming and editing paper types	2-7
● Loading paper in the multi purpose drawer	2-8
● Specifications (multi purpose drawer)	2-10
● Loading paper in the stand/3 x 500 sheet paper drawer	2-10
● Specifications (stand/3 x 500 sheet paper drawer)	2-10
● Loading paper in the stand/MPD & 2000 sheet paper drawer	2-11
● Specifications (stand/MPD & 2000 sheet paper drawer)	2-11
CUSTOM SETTINGS	2-13
● General procedure for custom settings	2-13
● About the settings	2-15
REPLACING THE TONER CARTRIDGE	2-16
STORAGE OF SUPPLIES	2-17
MISFEED REMOVAL	2-18
● Misfeed removal guidance	2-18
● Misfeed in the transport area, fusing area, and exit area	2-19
● Misfeed in the duplex module	2-20
● Misfeed in the paper feed area	2-21
REMOVING AN ORIGINAL MISFEED	2-23
● Removing a misfed original from the automatic document feeder	2-23
TROUBLESHOOTING	2-24

CHAPTER 3 PERIPHERAL DEVICES

DUPLEX MODULE	3-2
● Part names	3-2
● Specifications	3-2
● Loading paper in the bypass tray	3-3
● Troubleshooting (concerning the duplex module) ..	3-4
MAIL-BIN STACKER	3-5
● Part names	3-5
● Specifications	3-5
● Misfeed in the mail-bin stacker	3-6
FINISHER	3-7
● Part names	3-7
● Specifications	3-7
● Finisher functions	3-8
● Using the finisher functions	3-9
● Staple cartridge replacement	3-10
● Misfeed in the finisher	3-12
● Troubleshooting finisher problems	3-13
SADDLE STITCH FINISHER	3-14
● Part names	3-14
● Specifications	3-14
● Saddle stitch finisher functions	3-15
● Using the saddle stitch finisher	3-18
● Staple cartridge replacement and staple jam removal	3-19
● Misfeed in the saddle stitch finisher	3-22
● Troubleshooting (concerning the saddle stitch finisher)	3-24

CHAPTER 4 MAKING COPIES

AUTOMATIC DOCUMENT FEEDER	4-2
● Acceptable originals	4-2
PLACING ORIGINALS	4-3
CHECKING THE SIZE OF A PLACED ORIGINAL	4-5
● Manually setting the scanning size	4-5
STORING, DELETING, AND USING ORIGINAL SIZES	4-6
● Storing or deleting an original size	4-6
NORMAL COPYING	4-7
● Making copies with the automatic document feeder	4-7
● Automatic two-sided copying using the automatic document feeder	4-10
● Copying from the document glass	4-11
● Automatic two-sided copying from the document glass	4-13
ADJUSTING THE EXPOSURE	4-14
REDUCTION/ENLARGEMENT/ZOOM	4-15
● Automatic selection (auto image)	4-15
● Manual selection (preset copy ratios/zoom)	4-16
● XY ZOOM	4-18
SPECIAL PAPERS	4-20

CHAPTER 5 CONVENIENT COPY FUNCTIONS

SPECIAL MODES	5-2
● General procedure for using special functions	5-2
● Margin shift	5-3
● Erase	5-4
● Dual page copy	5-5
● Pamphlet copy	5-6
● Job build	5-8
● Tandem copy	5-9
● Covers/inserts	5-11
● Transparency film with insert sheets	5-22
● Multi shot	5-23
● Book copy	5-25
● Card shot	5-26
● Mirror image	5-28
● B/W reverse	5-28
● Print menu	5-29
STORING, USING AND DELETING JOB PROGRAMS	5-41
● Storing a job program	5-41
● Calling up a job program	5-42
● Deleting a stored job program	5-42
INTERRUPTING A COPY RUN	5-43

CHAPTER 6 MACHINE MAINTENANCE (FOR COPYING)

USER MAINTENANCE	6-2
● Cleaning the document glass and the automatic document feeder	6-2
● Cleaning the main charger of the photoconductive drum	6-2
TROUBLESHOOTING	6-3

CHAPTER 7 DOCUMENT FILING FUNCTION

OVERVIEW	7-2
● Document filing function	7-2
TO USE THE DOCUMENT FILING FUNCTION	7-4
● A look at the operation panel	7-4
● Saving files	7-4
● Main screen of document filing	7-5
● Document filing icons	7-5
SAVING A DOCUMENT IMAGE FILE	7-6
● Quick File	7-6
● Filing	7-7
● Print jobs	7-9
● Scan Save	7-10
CALLING UP AND USING A FILE	7-13
● Searching for and calling up a saved file	7-13
● Calling up and using a saved file	7-15
CUSTOM SETTINGS	7-21
● Creating, editing, and deleting user names and folders	7-21
ENTERING CHARACTERS	7-26
TROUBLESHOOTING	7-28

CHAPTER 8 SPECIFICATIONS

SPECIFICATIONS	8-2
LIST OF COMBINATION OF PERIPHERAL DEVICES ..	8-4
INDEX	8-5



CHAPTER 1

BEFORE USING THE PRODUCT

This chapter contains basic information that should be read before using the product.

	Page
INTRODUCTION	1-2
MAIN FEATURES	1-3
PART NAMES AND FUNCTIONS	1-9
• Exterior	1-9
• Interior	1-10
• Part names and functions of peripheral devices	1-11
• Operation panel	1-13
• Touch panel	1-14
TURNING THE POWER ON AND OFF	1-17
AUDITING MODE	1-18
• Using the machine when the auditing mode is enabled	1-18

INTRODUCTION

Thank you for purchasing a Olivetti digital multifunction copier.

Please read this manual before using the machine. In particular, be sure to read "INSTALLATION REQUIREMENTS" before using the machine.

Please keep this manual close at hand for reference whenever necessary.

This manual provides general information on using the machine, such as routine maintenance and how to load paper and remove misfeeds. It also explains how to use the copier and document filing functions.

Separate manuals have been provided for the fax function, printer function, and network scanner function.

■ Original and paper sizes

This machine allows use of standard sizes in both the AB and inch systems.

These are shown in the tables below.

Sizes in the AB system
A3
B4
A4
B5
A5

Sizes in the inch system
11" x 17" (LEDGER)
8-1/2" x 14" (LEGAL)
8-1/2" x 13" (FOOLSCAP)
8-1/2" x 11" (LETTER)
7-1/4" x 10-1/2" (EXECUTIVE)
5-1/2" x 8-1/2" (INVOICE)

■ The meaning of "R" in original and paper size indications

Some original and paper sizes can be placed in either the portrait or landscape orientations. To differentiate between landscape and portrait, the landscape orientation size indication will contain an "R". These are indicated as A4R, B5R, 8-1/2" x 11"R, 5-1/2" x 8-1/2"R, etc. Sizes that can be placed only in the landscape orientation (A3, B4, 11" x 17", 8-1/2" x 14", 8-1/2" x 13") do not contain the "R" in their size indication.

Size indication
with "R"

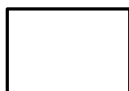

Landscape
orientation

Size indication
without "R"



Portrait orientation

MAIN FEATURES

The digital multifunction copier is capable of performing a variety of functions. This page shows features related to the copy function.

- Sort mode → See page 1-3
- Group mode → See page 1-3
- 2-sided Copy → See page 1-3
(When the duplex module is installed.)
- Exposure Adjustments → See page 1-3
- Reduction/Enlargement → See page 1-4
- XY Zoom → See page 1-4
- Margin Shift → See page 1-4
- Erase → See page 1-4
- Dual Page Copy → See page 1-4
- Pamphlet Copy → See page 1-4
- Job Build → See page 1-5
- Tandem Copy → See page 1-5
(Olivetti d-Copia 3501 / d-Copia 4501 version or when the document filling function has been added.)
- Covers/inserts → See page 1-5
- Transparency Insert → See page 1-5
- Multi Shot → See page 1-5
- Book Copy → See page 1-5
- Card Shot → See page 1-6
- Job programs → See page 1-6
- Mirror Image → See page 1-6
- B/W Reverse → See page 1-6
- Date → See page 1-6
- Stamp → See page 1-6
- Page numbering → See page 1-7
- Text → See page 1-7
- Interrupting a copy run → See page 1-7
- Offset mode → See page 1-7
(When the Finisher or Saddle stitch finisher is installed.)
- Staple sort mode → See page 1-7
(When the Finisher or Saddle stitch finisher is installed.)
- Saddle stitch → See page 1-7
(When the Saddle stitch finisher is installed.)
- Hole punching → See page 1-8
(When the Saddle stitch finisher and Punch Module are installed.)
- Document filing function → See page 1-8
(Olivetti d-Copia 3501/4501 version or when the document filling function has been added.)

Sort mode → See page 4-9

Copies can be collated.

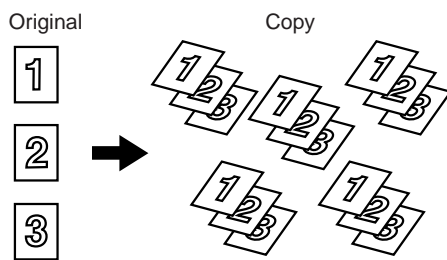

2-sided Copy → See pages 4-10, 4-13

Copy onto both sides of the paper using the document glass or the automatic document feeder.

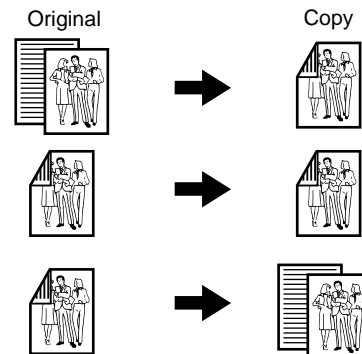

* When the duplex module is installed.

Group mode → See page 4-9

Copies can be grouped by page.

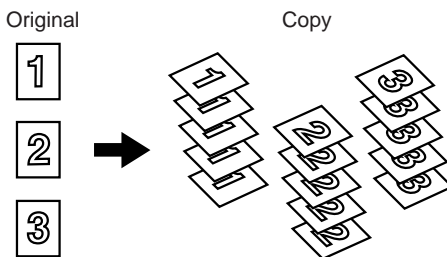

Exposure Adjustments → See page 4-14

The desired image type for the original can be selected.

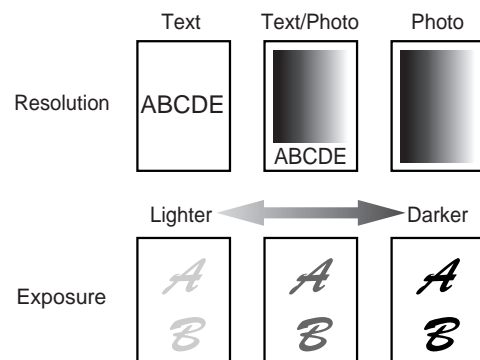

Reduction / Enlargement → See page 4-15

Copies can be enlarged or reduced to the desired size.

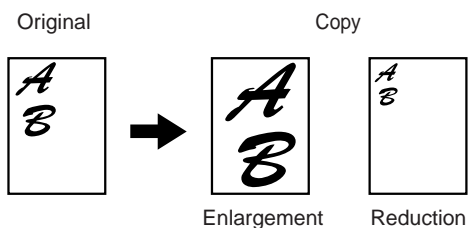

Erase → See page 5-4

Shadows that appear around the edges of copies of books or thick originals can be erased.

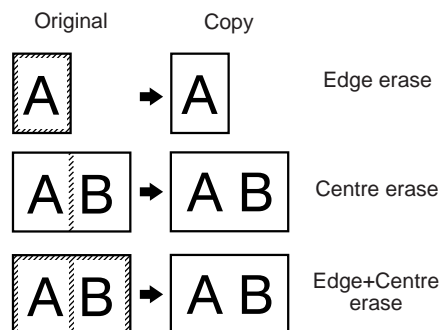

XY Zoom → See page 4-18

Separate ratio settings can be selected for the length and width of a copy.

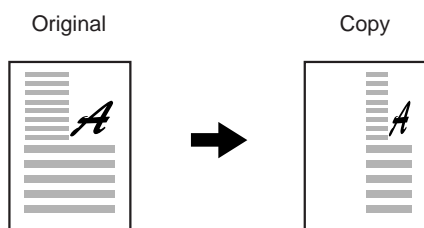

Dual Page Copy → See page 5-5

The left and right pages of a book can be successively copied onto separate sheets.

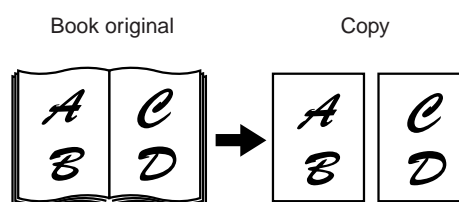

Margin Shift → See page 5-3

Margins can be added to copies.

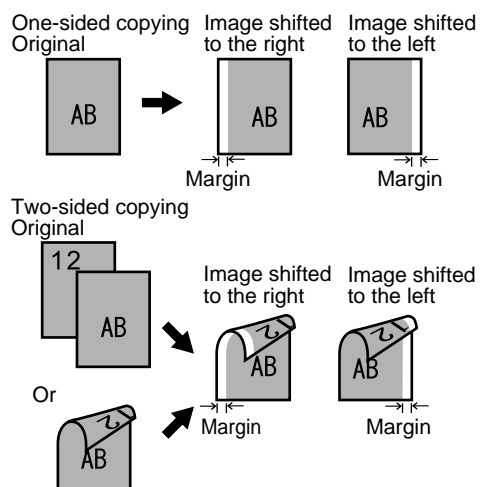

Pamphlet Copy → See page 5-6

One-sided or two-sided pamphlet style copies can be made.

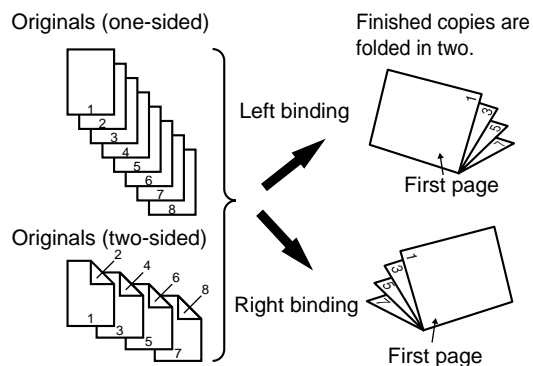

Job Build → See page 5-8

When you have a very large number of originals, the pages can be scanned in sets.

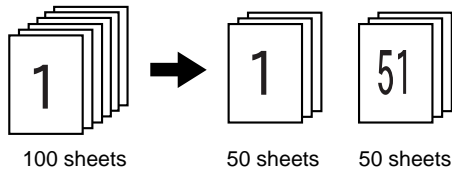

Transparency Insert → See page 5-22

Inserts can be automatically inserted between transparencies.

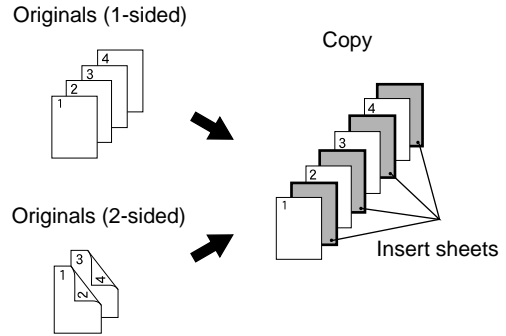

Tandem Copy → See page 5-9

Two machines can be used to run a large copy job in parallel.

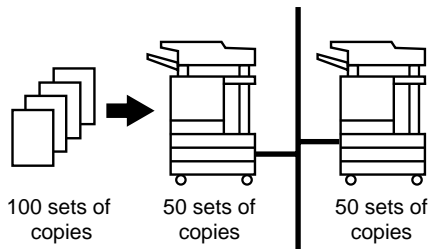

* Olivetti d-Copia 3501 / 4501 version or when the document filling function has been added.

Multi Shot → See page 5-23

Multiple original pages can be copied onto a single sheet of paper in a uniform layout.

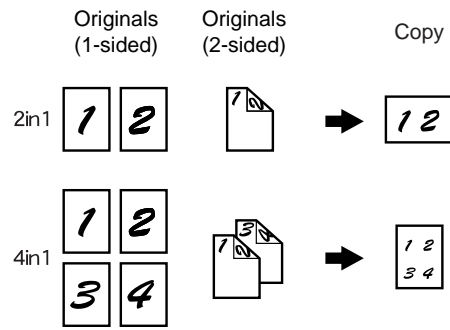

Covers/inserts → See page 5-11

Front covers, back covers, and inserts can be added. These can also be copied on.

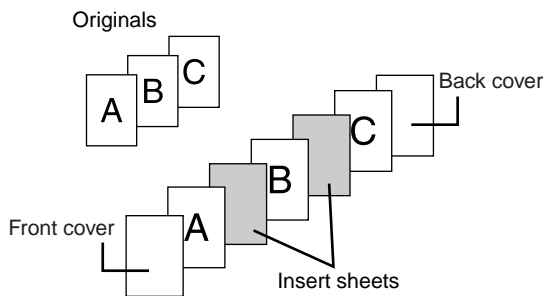

Book Copy → See page 5-25

Books and other bound originals can be copied pamphlet style.

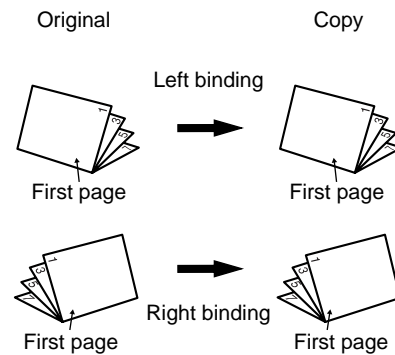

Card Shot → See page 5-26

The front and back of a card can be copied onto one sheet of paper.
 This function is convenient for making copies for certification purposes and helps save paper.

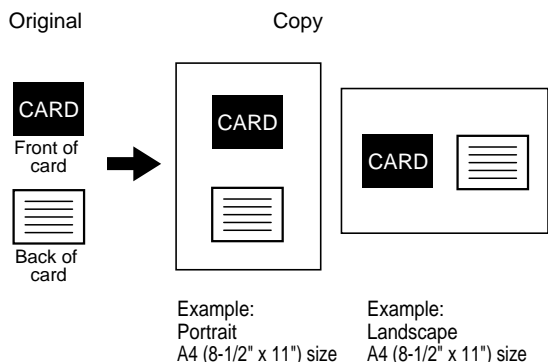

B/W Reverse → See page 5-28

White and black can be inverted on a copy to produce a negative image.

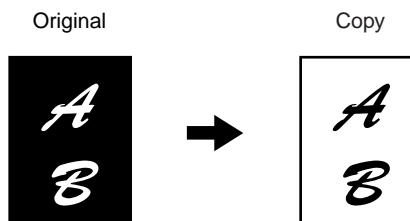

Job programs → See page 5-41

Various steps of a copy operation can be stored as a program, and up to 10 programs can be stored. Saving frequently used sets of settings in a program saves you the trouble of selecting those settings each time you wish to use them.

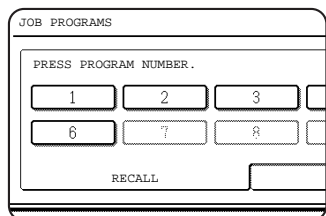

Date → See page 5-32

The date can be added to copies.

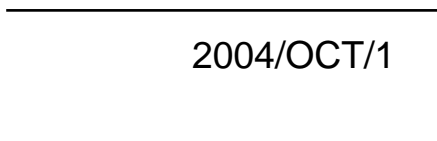

Mirror Image → See page 5-28

A mirror image copy can be made.

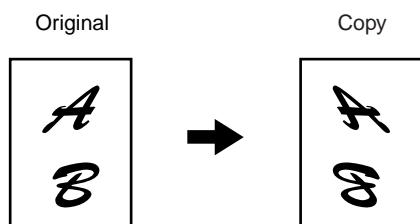

Stamp → See page 5-33

Reverse text can be added to copies ("stamp").



Page numbering → See page 5-34

Page numbers can be added to copies.

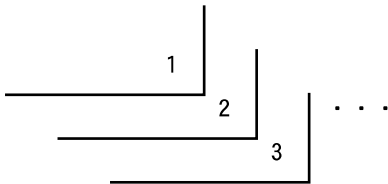

Text → See page 5-38

Entered text can be added to copies.



Interrupting a copy run → See page 5-43

A copy job in progress can be interrupted for a rush job.

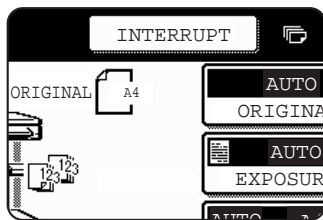

Offset mode → See page 3-8

Each set of output can be offset slightly from other sets for easy separation.

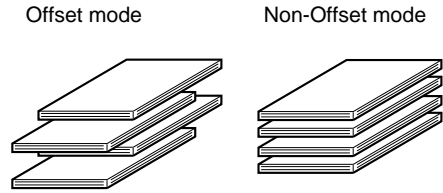

*When the Finisher or Saddle stitch finisher is installed.

Staple sort mode → See page 3-8, 3-16

Sets of copies can be automatically stapled.

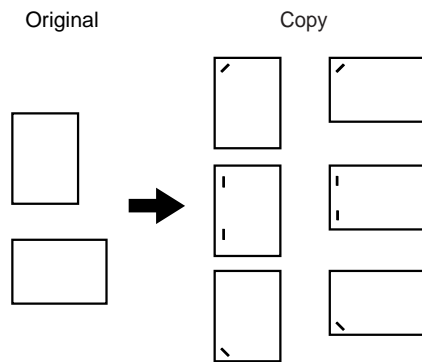

*When the Finisher or Saddle stitch finisher is installed.

Saddle stitch → See page 3-14

When a saddle stitch finisher is installed, copies can be automatically folded in half and stapled at the fold. (Use with the pamphlet function (see page 5-6) or book copy function (see page 5-25).)

Saddle stitch binding

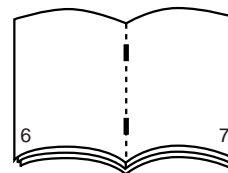

*When the Saddle stitch finisher is installed.

Hole punching → See page 3-17

Copies can be punched to add holes.

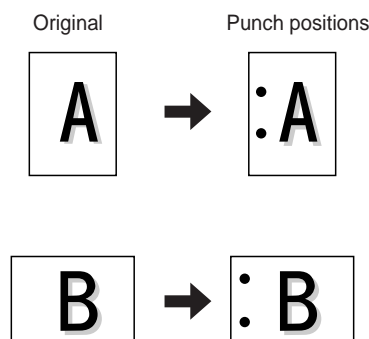

* When the saddle stitch finisher and punch module are installed.

Document filing function → See CHAPTER 7

A document image can be stored on the hard disk. A stored file can easily be called up and printed or transmitted.

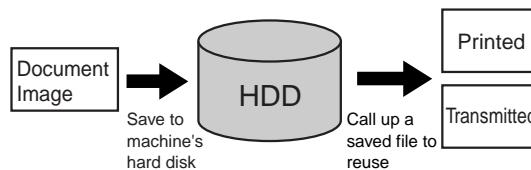

* Olivetti d-Copia 3501 / 4501 version or when the document filing function has been added.



ENERGY STAR is a U.S. registered mark.

The ENERGY STAR program is an energy reduction plan introduced by the United States Environmental Protection Agency in response to environmental issues and for the purpose of advancing the development and utilization of more energy efficient office equipment.

Energy saving features

This product has the following two power reducing modes to help conserve natural resources and reduce environmental pollution.

Preheat mode

When the machine remains in the standby state for the amount of time set in the key operator programs, preheat mode automatically reduces the temperature of the fusing unit to save power while the machine is on standby. When a fax or print job is received, or keys are pressed on the operation panel, or an original is placed for a copy, fax, or network scanner job, preheat mode automatically turns off.

Auto power shut-off mode

The auto power shut-off mode is the second level of power reduction. In this mode power is shut off to the fusing unit and the touch panel. In this state more energy is saved than in the preheat mode but the time to recover to the ready condition will be longer. The preset time to enter this mode can be set by a key operator program.

When this product is used as a printer, and either of the above modes is active, the mode will be deactivated automatically by an incoming job and the machine will automatically warm up and start to print when it has reached the ready temperature.

When this product is configured for multi-function operation, and either of the above modes is active, the mode will be deactivated as above by an incoming print job. Either mode will also be deactivated by operation of DOCUMENT FILING, IMAGE SEND or COPY mode key.

PART NAMES AND FUNCTIONS

Exterior

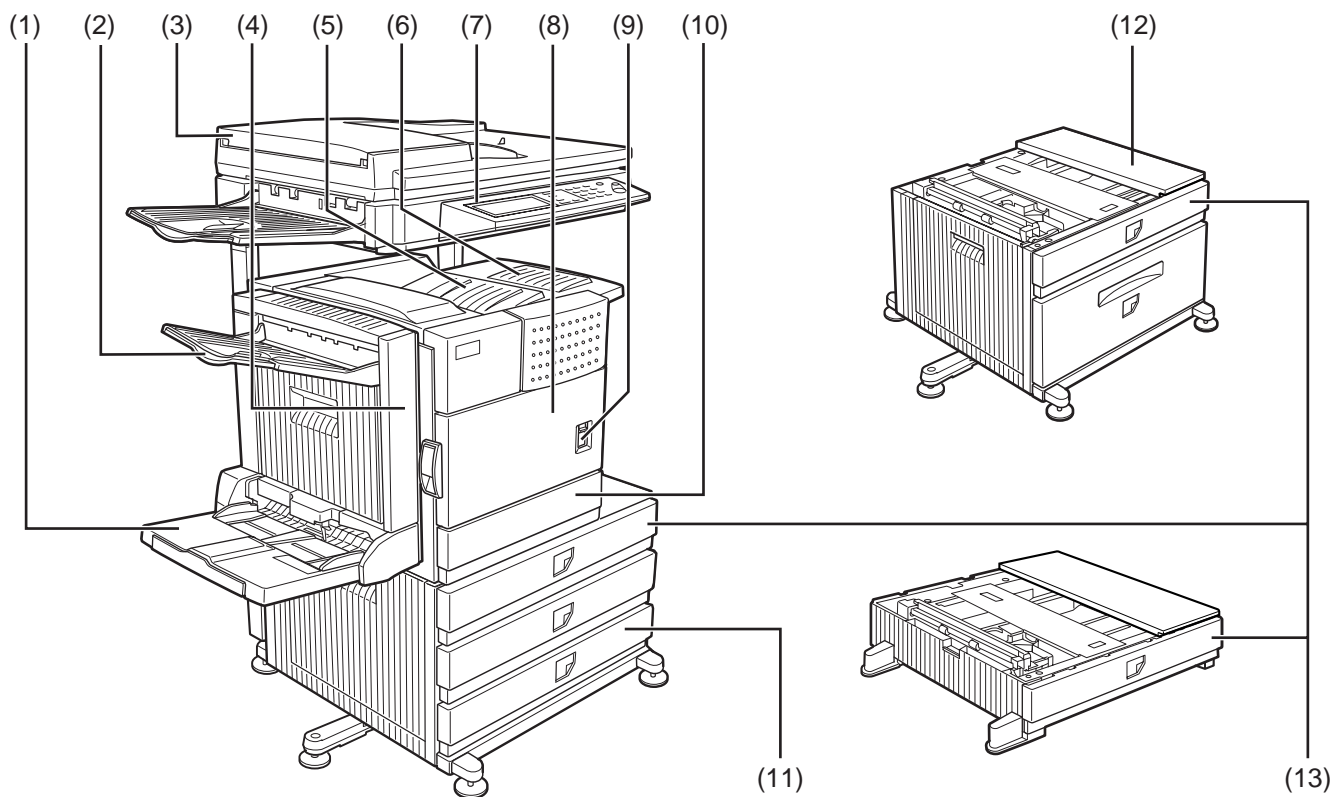

(1) Bypass tray*

(2) Exit tray*

(3) Automatic document feeder (See page 4-2.)

This automatically feeds and scans multiple sheet originals. Both sides of two-sided originals can be scanned at once.

(4) Duplex module*

Module for two-sided printing

(5) Upper paper output area (Centre tray)

Finished sheets are deposited here.

(6) Upper exit tray extension*

Provides support for large size paper.

(7) Operation panel

(8) Front cover

Open to add toner.

(9) Power switch

Press to turn power on and off.

(10) Paper tray 1

(11) Stand/3 x 500 sheet paper drawer*

(12) Stand/MPD & 2000 sheet paper drawer* (See page 2-11.)

(13) Multi purpose drawer* (See page 2-8.)

* (1), (2), (4), (6), (11), (12) and (13) are peripheral devices. For description of these devices, see page 1-11.

Interior

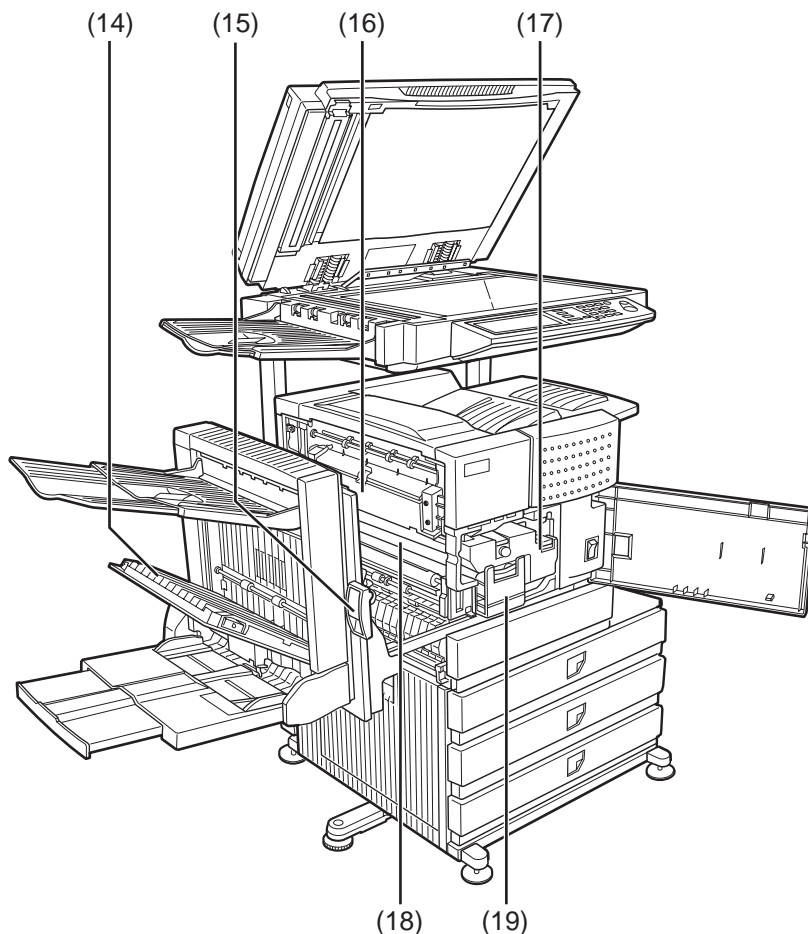

(14) Duplex module side cover

Open when a misfeed has occurred in the duplex module.

(15) Side cover latch

Push up to open the side cover when a misfeed has occurred in the main unit.

(16) Fusing unit

Lift up to open the side cover when a misfeed has occurred in the main unit.

CAUTION
The fusing unit is hot. Take care in removing misfed paper.

(17) Toner cartridge (drum/toner cartridge)

The toner cartridge must be replaced when indicated on the operation panel. (See page 2-15)

(18) Photoconductive drum

Images are formed on the photoconductive drum.

NOTE
Do not touch or damage the photoconductive drum.

(19) Cartridge lock lever

When replacing the drum, toner or developer cartridge, turn down this lever and pull it out.

Part names and functions of peripheral devices

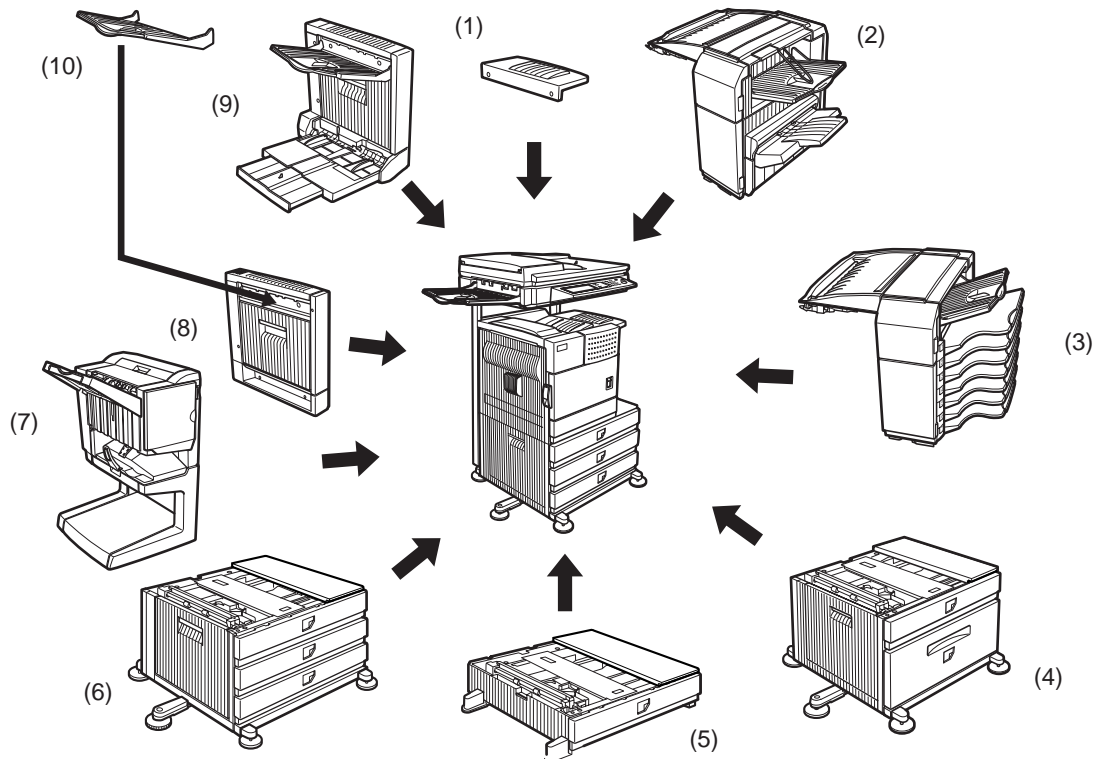

(1) Upper exit tray extension (AR-TE4)

Mount this unit to the upper paper exit tray. This extension is needed to support large size paper.

(2) Finisher (AR-FN6)

Output sheets can either be sorted in page order or grouped by page. Sorted sets or groups are offset stacked for easy separation when removed. Sorted sets can be delivered either stapled or unstapled.

(3) Mail-bin stacker (AR-MS1)

This unit is an output sorter that has seven receiving bins.

The bin to receive printed output can be selected in the printer driver. Each bin can be assigned to receive printed output by an individual person or by groups of people so that their prints are separated from other users making them easy to retrieve.

When this unit is installed, any copies or facsimile prints will be sent to the top tray and not into the mail bins.

(4) Stand/MPD & 2000 sheet paper drawer (AR-D28)

This paper feed unit contains an upper multi-purpose drawer (see item (6)) and a lower drawer which can hold a maximum of 2000 sheets of 80 g/m² (20 lbs.) paper.

(5) Multi purpose drawer (ARMU2)

Up to 500 sheets of 80 g/m² (20 lbs.) paper can be loaded. Also special papers such as envelopes (standard sizes only) and postcards can be set.

(6) Stand/3 x 500 sheet paper drawer (AR-D27)

This paper feed unit contains an upper multi-purpose drawer (see item (6)) and two lower drawers each of which can hold a maximum of 500 sheets of 80 g/m² (20 lbs.) paper.

(7) Saddle stitch finisher (AR-FN7)

The saddle stitch finisher can automatically place two staples for centreline binding of paper and fold them along the centreline.

An optional punch module is available for installation into the finisher.

(8) Duplex module (AR-DU3)

An optional duplex module must be installed for automatic two-sided printing.

(9) Duplex module/bypass tray (AR-DU4)

This module is basically the same as (9) above with the addition of a manual bypass paper feed unit.

(10) Exit tray (AR-TE3)

Mounted to the paper output port of a duplex module.

■ Other optional equipment

● Printer server card (AR-NC7)

This is an NIC card (Network Interface Card) that is required to use the network printer and network scanner functions.

● Printer server card (AR-NC8)

This is an NIC card (Network Interface Card) that is required to use the network printer and document filling functions, and the network scanner function.

● Barcode font kit (AR-PF1)

This kit adds bar code fonts to the machine.

● Data security kit (AR-FR21U, AR-FR22U)

The AR-FR21U is for models that have a hard disk drive, and the AR-FR22U is for models without a hard disk drive.

This kit is used to erase electronic data from the hard disk and memory immediately after a document is printed or transmitted.

● PS3 expansion kit (AR-PK6)

This kit provides compatibility of PostScript level 3 to the printer.

● Facsimile expansion kit (AR-FX12)

This kit is required to add fax function.

● Additional fax memory (8MB) (AR-MM9)

● Network scanner expansion kit (AR-EF3)

This kit is required to add the network scanning feature.

The network printer function is required to add on the network scanner function. On models that do not have the network printer function as a standard feature, the printer server card is required.

Some peripheral devices cannot be installed together while others may require the installation of one or more others to be functional. See page 8-4, "LIST OF COMBINATION OF PERIPHERAL DEVICES".

Peripheral devices are basically optional, but some are provided as standard equipment for some models.

Operation panel

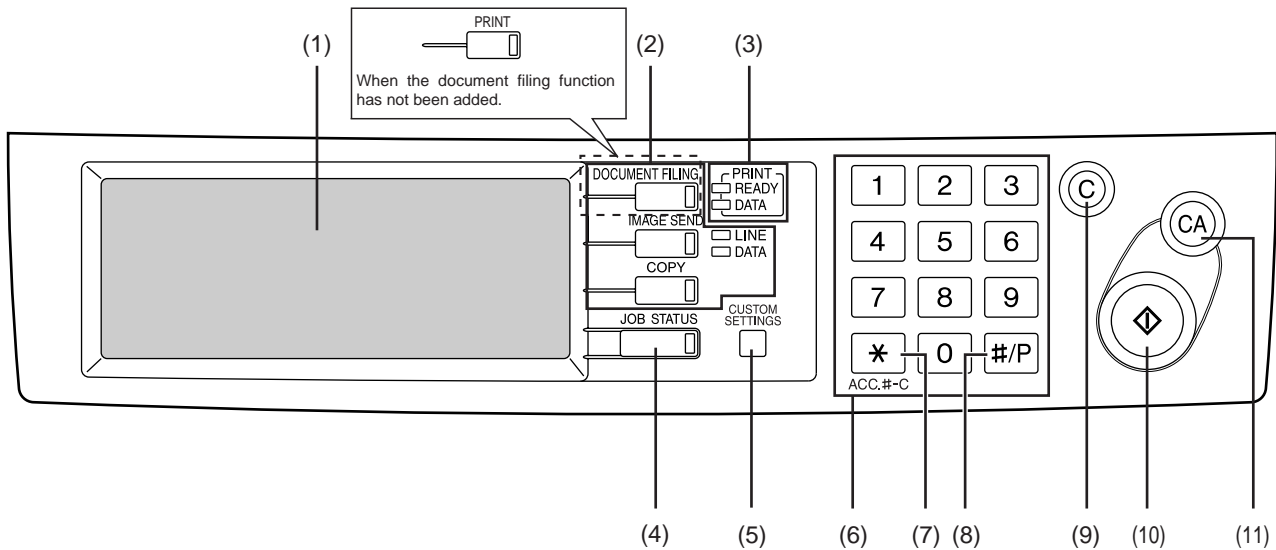

1

(1) Touch panel

The machine status, messages and touch keys are displayed on the panel. The document filing*¹, copy, network scanner*², and fax*³ functions are used by switching to the screen for the desired function. See the following page.

(2) Mode select keys and indicators

Use to change modes and the corresponding display on the touch panel.

[DOCUMENT FILING] key

Press to select the document filing mode*¹. (See page 7-5.)

When the document filing function has not been added, this key is the [PRINT] key. This key is pressed to change to the print mode screen when the printer function has been added.

[IMAGE SEND] key/LINE indicator/DATA indicator

Press to change the display to network scanner mode*² or fax mode*³. (See the "Operation manual (for network scanner)") and "Operation manual (for facsimile)".)

[COPY] key

Press to select the copy mode.

(3) PRINT mode indicators

READY indicator

Print data can be received when this indicator is lit.

DATA indicator

Lights up or blinks when print data is being received. Also lights up or blinks when printing is being performed.

*¹ When the document filing function has been added.

*² When the network scanner option is installed.

*³ When the fax option is installed.

(4) [JOB STATUS] key

Press to display the current job status. (See page 1-15.)

(5) [CUSTOM SETTINGS] key

This is used to store, edit, and delete user names and folder names for the document filing function*¹, and to configure the key operator programs and printer configuration settings. (See page 7-21)

(6) Numeric keys

Use to enter numeric values for various settings.

(7) [*] key ([ACC.#-C] key)

This key is used in copy mode, document filing mode*¹, network scanner mode*², and fax mode*³.

(8) [#]/P key

This is used as a program key when using the copy function, and to dial when using the fax function*³.

(9) [C] key (Clear key)

This key is used in copy mode, document filing mode*¹, network scanner mode*², and fax mode*³.

(10) [START] key

Use this key to start copying in copy mode, scan a document in network scanner mode*², or scan a document for transmission in fax mode*³.

(11) [CA] key (Clear all key)

This key is used in copy mode, document filing mode*¹, network scanner mode*², and fax mode*³. Use the key to cancel settings and perform an operation from the initial machine state.

Touch panel

The touch panel screens shown in this manual are printed images, and may appear different from the actual screens.

■ Using the touch panel

[Example 1]

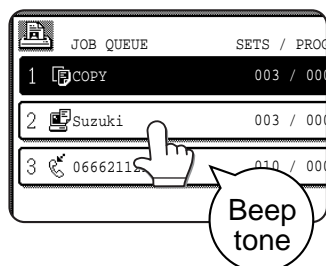

Items on the touch panel are easily selectable by touching the key associated with the item with a finger. Selection of an item will be accompanied with a beep tone* to confirm the item was selected.

Also, the key area for the item will be highlighted for visual confirmation.

* If a greyed out key is touched, double beeps will sound.

[Example 2]

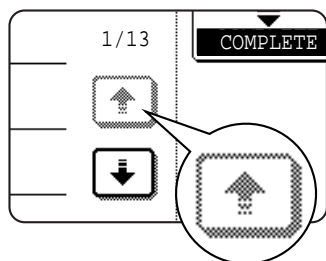

Keys which are greyed out on any screen are not selectable.

The confirmation beeps can be disabled by a key operator program. (See page 10 of the key operator's guide.)

■ Selecting a function

[Example 1]

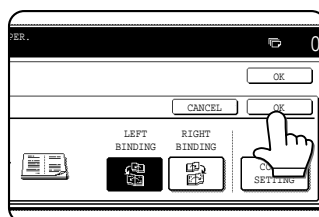

If a key is highlighted in a setting screen at the time the screen appears, the [OK] key can be pressed to store the selection without further operation.

[Example 2]

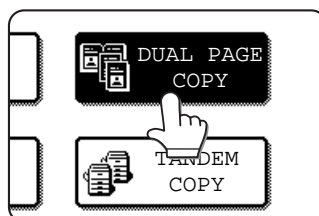

A function in the special functions screen is selected by touching the key so that it is highlighted. To cancel the selection, touch the highlighted key once again.

Copier feature

- Dual page copy
- Job build
- Tandem copy
- Mirror image
- B/W Reverse

[Example 3]

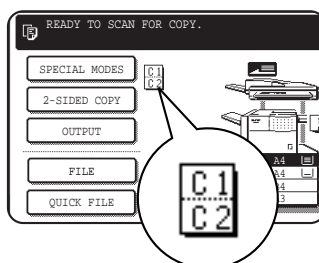

A corresponding icon representing the feature will appear on the touch panel and on the main screen of the mode selected. If this icon is touched, the setting screen of the function (or a menu screen) will appear, allowing the settings to be checked or adjusted and the function to be cancelled easily.

■ Job status screen (common to print, copy, fax, network scan and Internet fax)

This screen is displayed when the [JOB STATUS] key on the operation panel is pressed.

This screen can be used to display the "JOB QUEUE" (showing stored jobs and the current job) or the "COMPLETE" job list (showing finished jobs). This screen can be used to check jobs, interrupt a job in progress to perform another job, and cancel a job.

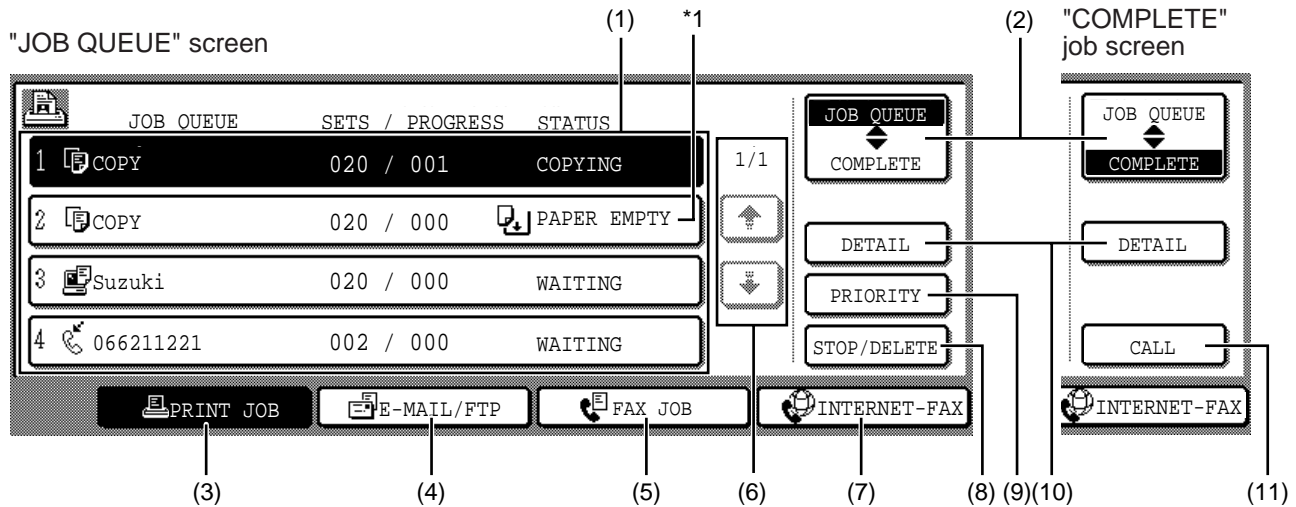

(1) Job list

The displayed jobs in the job list are themselves operation keys. To cancel printing or to give a job the highest print priority, touch the relevant job key to select the job and execute the desired operation using the keys described in (8) and (9).

This shows the current job and the jobs waiting to be run. The icons to the left of the jobs in the queue show the job mode. The document filing reprint job icon is highlighted.

Note that the icon does not become highlighted during retransmission of a fax/image transmission job.

*1 "PAPER EMPTY" in the job status display

When a job status display indicates "PAPER EMPTY", the specified paper size for the job is not loaded in any of the trays.

In this case, the job will be suspended until the required paper is loaded. Other stored jobs will be printed (if possible) until the required paper is loaded. (Other jobs will not be printed if the paper runs out during printing.) If you need to change the paper size because the specified paper size is not available, touch the current job key to select it and then touch the [DETAIL] key described in (10).

(2) Mode select key

This switches the job list display between "JOB QUEUE" and "COMPLETE".

"JOB QUEUE": Shows stored jobs and the job in progress.

"COMPLETE": Shows finished jobs.

Files saved using the "FILE"*2 and "QUICK FILE"*2 functions and finished broadcast transmission jobs appear as keys in the finished job screen. The "FILE"*2 or "QUICK FILE"*2 job keys in the finished job screen can be touched, followed by the [CALL] key*2, to call up a finished job and print or transmit it. A finished broadcast transmission job key can be touched followed by the [DETAIL] key to check the result of the transmission.

*2 Can only be used on the d-Copia 3501/4501 version, or when the document filling function has been added.

	Print mode		Copy mode
E-MAIL/FTP mode			
	Scan to e-mail job		Scan to FTP job
	Scan to Desktop job		
Fax mode			
	Fax send job		Fax reception job
	PC-Fax send job		
Internet Fax mode			
	i-Fax send job		i-Fax reception job
	PC-Internet Fax send job		

(3) [PRINT JOB] key

This displays the print job list of print mode (copying, printing, fax reception, Internet fax reception, and self printing).

(4) [E-MAIL/FTP] key

This displays the transmission status and finished jobs of scan mode (Scan to e-mail, Scan to FTP, and Scan to Desktop) when the network scanner option is installed.

(5) [FAX JOB] key

This displays the transmission/reception status and finished jobs of fax mode (fax and PC-Fax) when the fax option is installed.

(6) Display switching keys

Use to switch the page of the displayed job list.

(7) [INTERNET-FAX] key

This displays the transmission/reception status and finished jobs of Internet fax mode and PC Internet fax mode when the network scanner option is installed.

(8) [STOP/DELETE] key

Use to cancel or delete the current job or delete the stored job. Note that printing of received faxes and received Internet faxes cannot be cancelled or deleted.

(9) [PRIORITY] key

Touch this key after selecting a stored job in this [JOB QUEUE] list to print the job ahead of the other jobs.

Note that a job in progress cannot be interrupted if it is an interrupt copy job or if it is a list print job.

(10) [DETAIL] key

This shows detailed information on the selected job. Files saved using the "FILE"*² and "QUICK FILE"*² functions and finished broadcast transmission jobs appear as keys in the finished job screen. A Quick File in the finished job screen or the [Filing] key*² can be touched, followed by the [CALL] key*², to call up a finished job and print or transmit it. A finished broadcast transmission job key can be touched followed by the [DETAIL] key to check the result of the transmission.

(11) [CALL] key*²

When this key is touched after selecting a job in the COMPLETE job status screen (a job stored using the FILE or QUICK FILE keys of the document filing function), the "JOB SETTINGS" menu screen appears to let you resend or reprint the finished job. (See "Document filing function" on page 7-2.)

*² Can only be used on the Olivetti d-Copia 3501 / 4501 version or when the document filing function has been added.

TURNING THE POWER ON AND OFF

Use the power switch on the front of the machine to turn the power on or off.

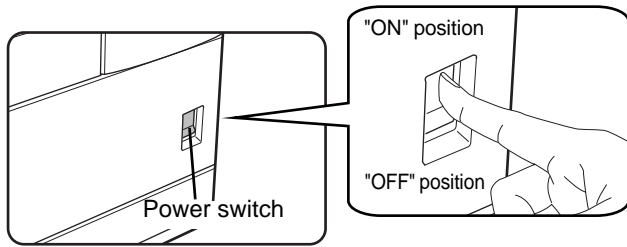

CAUTION

Before turning off the main power switch, make sure that the communication and data indicators are not blinking on the operation panel. Turning off the main power switch or unplugging the power cord while the lights are blinking may damage the hard disk and cause the data being stored or received to be lost.

1

NOTES

- Turn both switches off and unplug the power cord if you suspect a machine failure, if there is a bad thunderstorm nearby, or when you are moving the machine.
- If the fax function has been added, always keep the fax power switch turned on. Faxes cannot be received if the fax power switch is turned off. (Faxes can be received when the main power switch is turned off.)

AUDITING MODE

Auditing mode can be enabled to keep track of the number of pages printed and transmitted (scanned) by each account (up to 500 accounts can be established). The page counts can be viewed and totaled as needed.

<This mode is enabled in the key operator programs separately for the copy, printer, fax, Internet fax, network scanner, document filing functions. (Page 7 of the key operator's guide)>

Using the machine when the auditing mode is enabled

The procedure for making copies when auditing mode has been enabled for the copy function is explained below.

NOTES

- When auditing mode is enabled for document filing and fax/image transmission, a message will appear asking you to enter your account number each time you switch to the main screen of one of those functions in the touch panel. Enter your account number in the same way as for copy mode, and then begin the scanning procedure.
- When the account counter is turned on for the printer function, you must enter your account number in the setting screen of the printer driver on your computer in order to print.

When the auditing mode is turned on, the right message appears on the touch panel.

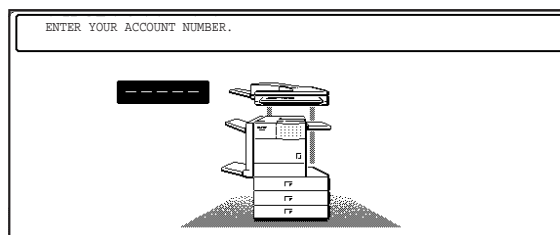

When the above screen appears, enter your 5-digit account number and then begin the copying procedure.

1 Enter your account number (5 digits) with the numeric keys.

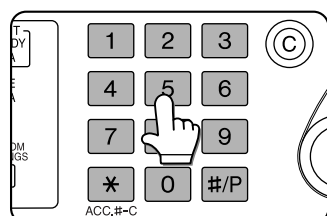

As you enter your account number, the hyphens (-) change to asterisks (*). If you enter an incorrect digit, press the [C] (Clear) key and re-enter the correct

digit.

When a correct account number is entered, the following message will appear.

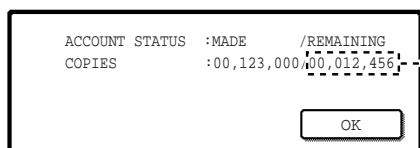

If a limit has been set by a key operator program for the number of copies that can be made by the account, the remaining number that can be made is displayed.

Check the number in the display and touch the [OK] key.

NOTE

If "ACCOUNT NUMBER SECURITY" is enabled in the key operator programs and an incorrect account number is entered three times in a row, "PLEASE SEE YOUR KEY OPERATOR FOR ASSISTANCE." will appear. (Page 8 of the key operator's guide.) Operation is not possible while this message appears (about one minute).

2 Follow the appropriate steps to perform the copy job.

When copying is begun, the following message will appear.

READY TO SCAN FOR COPY.
PRESS [ACC.#-C] WHEN FINISHED.

To perform an interrupt copy job (page 5-43), touch the [INTERRUPT] key and then enter your account number as explained in step 1. The following message will appear.

COPY INTERRUPT MODE.
READY TO SCAN FOR COPY.

3 When the copy job is finished, press the [*] key ([ACC.#-C] key)

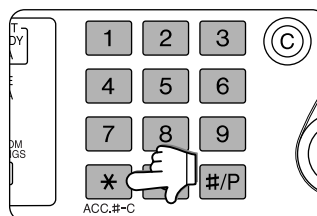



CHAPTER 2

MANAGING THE MACHINE

This chapter explains how to load paper, replace the toner cartridge, and remove paper misfeeds. It also contains information about supplies.

	Page
LOADING PAPER	2-2
• Loading paper in paper tray 1	2-2
• Changing the paper size in paper tray 1	2-2
• Specifications of paper trays	2-3
• Setting the paper type and paper size	2-5
• Setting the paper size when a special size is loaded	2-6
• Programming and editing paper types	2-7
• Loading paper in the multi purpose drawer	2-8
• Specifications (multi purpose drawer)	2-10
• Loading paper in the stand/3 x 500 sheet paper drawer	2-10
• Specifications (stand/3 x 500 sheet paper drawer)	2-10
• Loading paper in the stand/MPD & 2000 sheet paper drawer	2-11
• Specifications (stand/MPD & 2000 sheet paper drawer)	2-11
CUSTOM SETTINGS	2-12
• General procedure for custom settings	2-12
• About the settings	2-14
REPLACING THE TONER CARTRIDGE	2-15
STORAGE OF SUPPLIES	2-16
MISFEED REMOVAL	2-17
• Misfeed removal guidance	2-17
• Misfeed in the transport area, fusing area, and exit area	2-18
• Misfeed in the duplex module	2-19
• Misfeed in the paper feed area	2-20
REMOVING AN ORIGINAL MISFEED	2-22
• Removing a misfed original from the automatic document feeder ..	2-22
TROUBLESHOOTING	2-23

LOADING PAPER

If the paper runs out during printing, a message will appear in the display. Follow the procedure below to load paper.

NOTES

- Do not use curled or folded paper. Doing so may cause a misfeed.
 - For best results use paper supplied by Olivetti. (See page 2-4.)
 - When you change the paper type and size in paper tray 1, set the paper type and size referring to "Setting the paper type and paper size" (page 2-5).
 - Do not place heavy objects or press hard on any tray which is pulled out.
 - Load paper with the print side face up. However, when the paper type is set to "PRE-PRINTED", "PRE-PUNCHED" or "LETTER HEAD", load the paper face down*.
- * If the two-sided function is disabled using "DISABLING OF DUPLEX" in the key operator programs (page 11 of the key operator's guide), load the paper face up.

Loading paper in paper tray 1

1 Pull out paper tray 1.

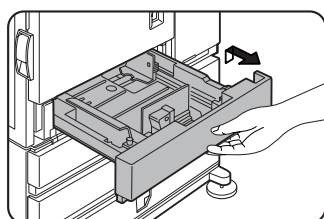

Gently pull the tray out until it stops.

2 Load paper into the tray.

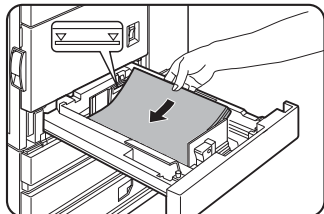

Do not load paper above the maximum height line (approximately 500 sheets of 80 g/m² (20 lbs.) paper).

3 Gently push tray 1 into the machine.

Push the tray firmly all the way into the machine.

4 Set the paper type.

If you change the paper type setting if the paper type is changed in either paper tray, refer to "Setting the paper type and paper size" (page 2-5).

5 Loading paper in paper tray 1 is now complete.

Changing the paper size in paper tray 1

For paper tray 1, A4, B5 or 8-1/2" x 11" size paper can be set. Use the following procedure to change the size as needed.

1 Pull out paper tray 1.

If paper remains in the tray, remove it.

2 Adjust the guide plates A and B in the tray to the length and width of the paper.

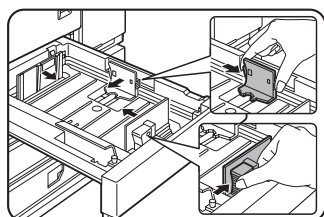

The guide plates A and B are slidable. Adjust them to the paper size to be loaded while squeezing their lock levers.

4 Gently push tray 1 into the machine.

Push the tray firmly all the way into the machine.

5 Set the paper size.

Be sure to set the paper size and paper type referring to "Setting the paper type and paper size" (page 2-5).

If this is not done, paper misfeeds will occur.

6 Changing paper size in paper tray 1 is now complete.

3 Load paper into the tray.

Specifications of paper trays

The specifications for types and sizes of paper that can be used in each tray are shown below.

Tray	Tray No. (tray name)	Applicable paper types	Applicable paper sizes	Paper weight	
Paper tray 1	Tray 1	Plain paper (Refer to the next page for applicable plain papers.)	● A4, B5, 8-1/2" x 11"	60 to 105 g/m ² or 16 to 28 lbs.	
Multi purpose drawer /bypass tray	Tray 2 /bypass tray	Plain paper (Refer to the next page for applicable plain papers.)	<ul style="list-style-type: none"> ● If "AUTO-AB" is selected in setting the paper type and paper size (page 2-5), the following paper sizes can be used with the automatic detection function: A3, B4, A4, A4R, B5, B5R, A5R, 8-1/2 x 13" ● If "AUTO-INCH" is selected in setting the paper type and paper size (page 2-5), the following paper sizes can be used with the automatic detection function: 11" x 17", 8-1/2" x 14", 8-1/2" x 11", 8-1/2" x 11"R, 7-1/4" x 10-1/2", 5-1/2" x 8-1/2"R ● Non-standard sizes 	60 to 128 g/m ² or 16 to 34 lbs.	
		Special paper (Refer to the next page for applicable special papers.)	<ul style="list-style-type: none"> ● Thick paper ● Labels, transparency film 	<ul style="list-style-type: none"> ● If "AUTO-AB" is selected in setting the paper type and paper size (page 2-5), the following paper sizes can be used with the automatic detection function: A4, A4R, B5, B5R ● If "AUTO-INCH" is selected in setting the paper type and paper size (page 2-5), the following paper sizes can be used with the automatic detection function: 8-1/2" x 11", 8-1/2" x 11"R ● Non-standard sizes 	See the remarks for special paper on the next page.
		Postcard	● Japanese official postcard		
		Envelopes can only be fed from the multi-purpose drawer. Applicable stock weight for envelopes is 75 to 90 g/m ² or 20 to 23 lbs.	<ul style="list-style-type: none"> ● Applicable standard size envelopes: COM-10, Monarch, DL, C5, ISO B5 CHOKEI 3 ● Non-standard size 		
Stand /3 x500 sheet paper drawer	Upper	Tray 2	Same as multi purpose drawer		
	Middle	Tray 3	Plain paper (Refer to the next page for applicable plain papers.) <ul style="list-style-type: none"> ● If "AUTO-AB" is selected in setting the paper type and paper size (page 2-5), the following paper sizes can be used with the automatic detection function: A3, B4, A4, A4R, B5, B5R, 8-1/2" x 13" ● If "AUTO-INCH" is selected in setting the paper type and paper size (page 2-5), the following paper sizes can be used with the automatic detection function: 11" x 17", 8-1/2" x 14", 8-1/2" x 11", 8-1/2" x 11"R, 7-1/4" x 10-1/2"R 	60 to 105g/m ² or 16 to 28 lbs.	
	Lower	Tray 4			
Stand /MPD & 2000 sheet paper drawer	Upper	Tray 2	Same as multi purpose drawer		
	Lower	Tray 3	Plain paper (Refer to the next page for applicable plain papers.)	● A4, 8-1/2" x 11" 60 to 105g/m ² or 16 to 28 lbs.	

■ Applicable plain paper

For satisfactory results, plain paper must conform to the following requirements.

	Paper in AB system	Paper in inch system
	A5 to A3	5-1/2" x 8-1/2" to 11"x17"
Plain paper	60 to 105 g/m ² or 16 to 28 lbs.	
Recycled, coloured, pre-punched, pre-printed and letterhead papers must conform to the same conditions as above.		

■ Applicable special paper

For satisfactory results, special paper must conform to the following requirements.

	Type	Remarks
Special paper	Thick paper	<ul style="list-style-type: none"> ● For A5 to A4 or 5-1/2" x 8-1/2" to 8-1/2" x 11" sizes, thick paper ranging from 60 to 128 g/m² or 16 to 34 lbs. can be used. ● For sizes larger than A4 or 8-1/2" x 11", thick paper ranging from 60 to 105 g/m² or 16 to 28 lbs. can be used. ● Other thick papers Index stock (176 g/m² or 65 lbs.) can be used. Cover stock (200 to 205 g/m² or 110 lbs.) can be used but only for A4, 8-1/2" x 11" paper in the portrait orientation. ● For A5 or 5-1/2" x 8-1/2" paper, the orientation must be landscape.
	Transparency film, labels, and tracing paper	<ul style="list-style-type: none"> ● Use Olivetti recommended paper. Do not use labels other than Olivetti recommended labels. Doing so may leave adhesive residue in the machine, causing paper misfeeds, smudges on prints or other machine trouble.
	Postcards	<ul style="list-style-type: none"> ● Japanese official postcards can be used.
	Envelopes	<ul style="list-style-type: none"> ● Applicable standard envelopes: COM-10, Monarch, DL, C5, ISO B5, CHOKEI 3 ● Envelopes can only be fed from the tray 2. Applicable paper stock weight for envelopes is 75 to 90 g/m ² or 20 to 23 lbs..

■ Paper that can be used for automatic two-sided printing

Paper used for automatic two-sided printing (paper that can be fed through the duplex module) must meet the following conditions:

Paper type :Plain paper as specified above.

Paper size :Must be one of the following standard sizes: A3, B4, A4, A4R, B5, B5R or A5R (11" x 17", 8-1/2" x 14", 8-1/2" x 13", 8-1/2" x 11", 8-1/2" x 11"R or 5-1/2" x 8-1/2"R)

Paper weight:64 to 105 g/m² (16 to 28 lbs.)

NOTES

- Special papers (explained above) cannot be used for automatic two-sided printing.
- Various types of plain paper and special paper are sold. Some of these cannot be used in the machine. Please consult your retailer or your dealer when buying paper.
- The image quality and toner fusibility of special papers may change due to ambient conditions, operating conditions, and paper characteristics, resulting in image quality inferior to that of Olivetti standard paper.

Setting the paper type and paper size

Follow these steps to change the paper type setting if the paper type is changed in either paper tray. For the paper types that can be used in each tray, see page 2-3.

1 Press the [CUSTOM SETTINGS] key.

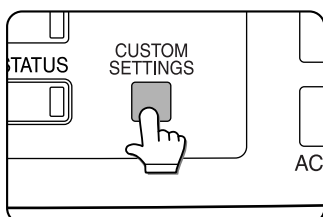

The custom setting menu screen will appear.

2 Touch the [PAPER TRAY SETTINGS] key.

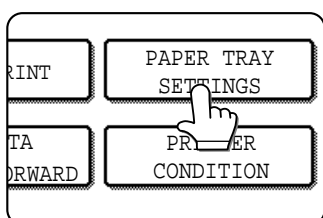

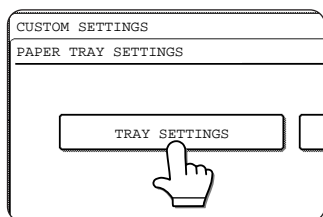

The paper tray selection screen will appear.

3 Touch the [TRAY SETTINGS] key.

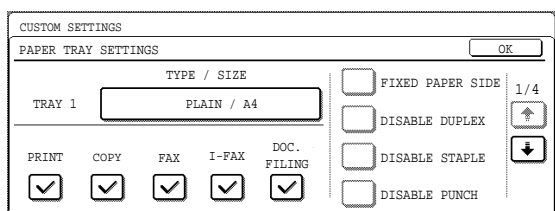

4 Display the setting screen of the desired paper tray.



Touch the  key or  key to display the setting screen of the desired paper tray.

NOTE

To automatically switch to a tray with the same size and type of paper (if there is one) in the event that the paper tray runs out of paper, display the last screen with the  key and select [AUTO TRAY SWITCHING].

5 Touch the [TYPE / SIZE] key.

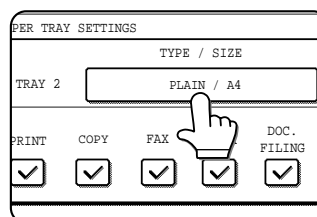

6 Select the type of paper that was loaded in the tray.

Example: The paper type of tray 2 is selected

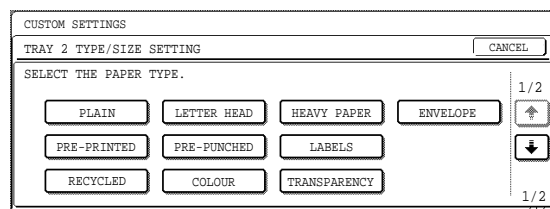

Touch the desired paper type to select it. The paper size setting screen will appear.

NOTE

Heavy paper, label sheets and transparency film cannot be used in trays 1, 3, and 4. Envelopes can only be placed in tray 2.

■ User type

Set a user type when a paper type is not available as an option. To select a user type, touch the  key in the screen of step 6 to display the user type selection screen. To store or edit a user type name or set tray attributes, see "Programming and editing paper types" on page 2-7.

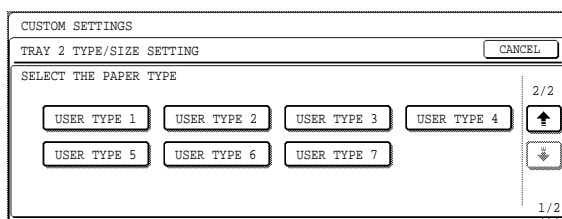

7 Select the size of paper that was loaded in the tray.

Touch the appropriate keys (checkboxes).

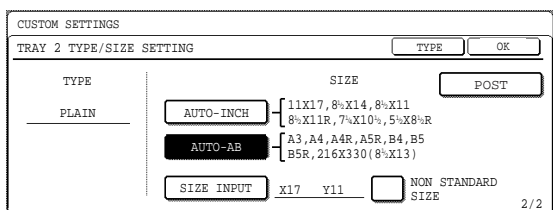

- [AUTO-INCH] key : Select when you have loaded an inch-based size of paper.
- [AUTO-AB] key : Select when you have loaded an AB size of paper.
- [SIZE INPUT] key : Select to directly enter a paper size (see page 2-6).
- [NON STANDARD SIZE] checkbox : Select when you have loaded a non-standard size of paper (see page 2-6).
- [POST] key : Select this when you have loaded postcards.

NOTE
 Sizes that can be selected vary depending on the selected paper type.

8 Touch the [OK] key in the size setting screen.

You will return to the tray setting screen of step 4.

9 Select output functions that can be used with the selected tray.

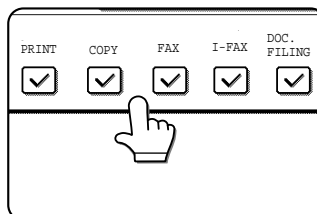

Touch the checkboxes under the desired items to select them. Checkboxes that can be selected will vary depending on the options that are installed.

10 Configure paper settings for each tray and then touch the [OK] key to exit.

NOTE
 The type and size of paper loaded in the bypass tray can also be set from the paper selection screen. Touch the [PAPER SELECT] key at the top of the base screen to display the paper selection screen, touch the [PAPER SELECT] key for the bypass tray, and then go to step 6.

Setting the paper size when a special size is loaded

NOTE
 Special sizes of paper cannot be loaded in trays 1, 3 and 4.

Tray 2 and the bypass tray

1 Perform steps 1 through 6 of "Setting the paper type and paper size" (see page 2-5).

2 Touch the [SIZE INPUT] key and then touch the [AB] tab.

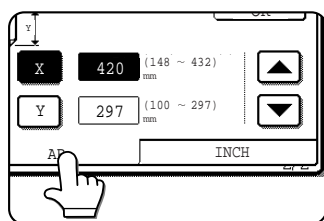

The size entry palette appears.

3 Touch the [▲] key or the [▼] key to enter the X (width) and Y (length) dimensions of the paper.

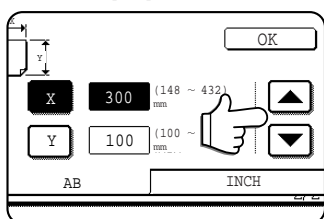

Entry of the X dimension (width) is initially selected. Touch the [Y] key and enter the Y dimension (length) in the same way as the X dimension.

4 Touch the [OK] key.

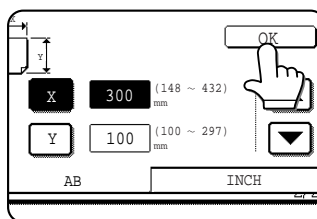

You will return to the size setting screen of step 2.

5 If the paper is a non-standard size, select the [NON STANDARD SIZE] checkbox.

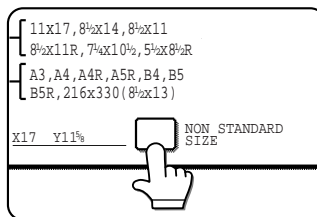

6 Perform steps 8 through 10 of "Setting the paper type and paper size" (see page 2-6).

Programming and editing paper types

To program or edit the name of a paper type or set paper attributes, follow the steps below.

1 Follow steps 1 and 2 of "Setting the paper type and paper size" (page 2-5)

2 Touch the [PAPER TYPE REGISTRATION] key.

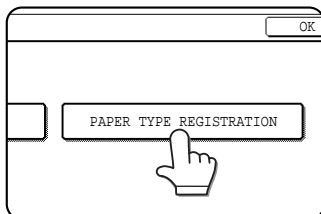

3 Select the paper type that you wish to program or edit.

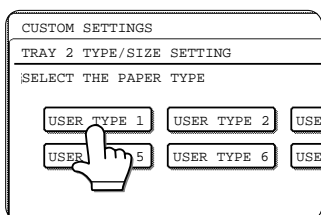

4 Touch the [TYPE NAME] key.

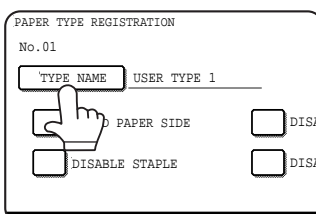

A character entry screen appears.

Enter a type name (maximum of 14 characters). (See page 7-26 to enter characters.)

5 Set the attributes of the paper tray.

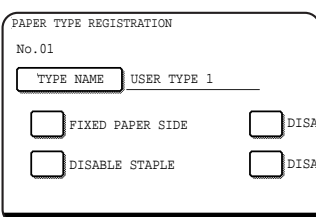

Touch the checkboxes to the left of the items to select them.

"FIXED PAPER SIDE" : Select when paper is to be loaded print side down in the tray. Make sure a checkmark does not appear when paper is to be loaded print side up.

- If the two-sided function is prohibited in "DISABLING OF DUPLEX" in the key operator programs (page 11 of the Key operator's guide), do not use this setting.

"DISABLE DUPLEX" : Prohibits two-sided printing. Enable when the back side of the paper cannot be printed on.

"DISABLE STAPLE" : Prohibits stapling. Enable when using special papers such as transparency film and label sheets.

"DISABLE PUNCH" : Prohibits punching. Enable when using special papers such as transparency film and label sheets.

NOTE

"FIXED PAPER SIDE" and "DISABLE DUPLEX" cannot be simultaneously enabled.

6 Touch the [EXIT] key to exit the programming/editing procedure.

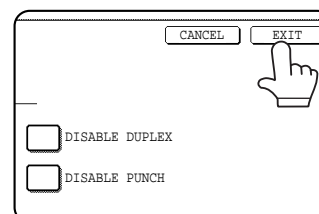

2

Loading paper in the multi purpose drawer

The method of loading paper into the multipurpose drawer is the same as for paper tray 1 described on page 2-2. For specifications of paper, see page 2-3. When loading envelopes, postcards or transparency film, follow the descriptions below.

- Two maximum height lines are indicated: one for plain paper and one for special paper.

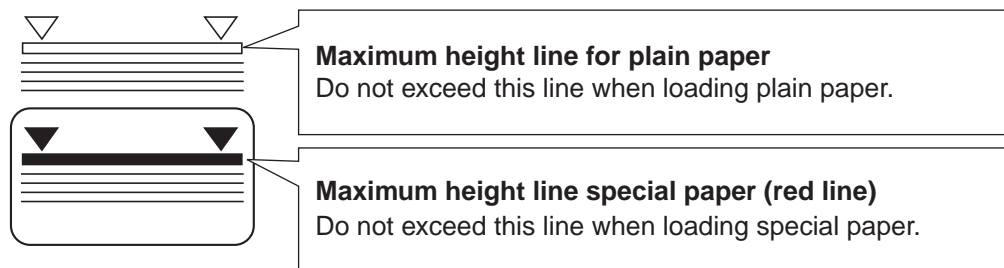

■ How to change the paper size

To change the paper size or paper type when paper is loaded into the multi purpose drawer, refer to page 2-5 for details.

■ Setting envelopes or postcards

When setting envelopes or postcards in the multi purpose drawer, set them in the orientation shown below.

Loading postcards

Load postcards print side up to the rear left of the tray as shown.

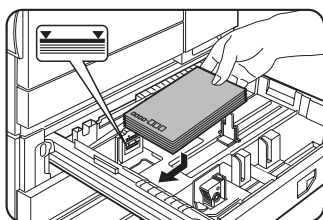

Loading envelopes

Envelopes can only be printed on the address side. Be sure to place envelopes with the address side up and the top of the envelope to the rear.

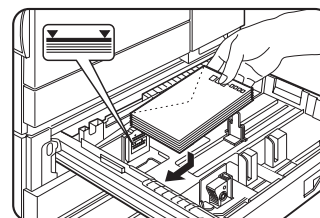

Printing onto envelopes or postcards

- Attempting to print onto both sides of envelopes or postcards may result in misfeeds or poor prints.
- Do not use paper that has already been printed on by a thermal transfer or inkjet printer. In particular, paper that has been printed on by a thermal transfer printer (such as a word processor that uses a cassette) may cause missing characters and smudges.
- To avoid wrinkling, misfeeds or poor printing, make sure the postcard or envelopes stock is not curled.

Printing onto envelopes

- Do not use envelopes that have metal clasps, plastic snaps, string closures, windows, linings, self-adhesive patches or synthetic materials. Attempting to print on these may cause misfeeds, inadequate toner adherence or other trouble.
- Creases or smudging may occur. This is especially true of embossed surfaces and other irregular surfaces.
- Under high humidity and temperature conditions the glue flaps on some envelopes may become sticky and be sealed closed when printed.
- Use only envelopes which are flat and crisply folded. Curled or poorly formed envelopes may be poorly printed or may cause misfeeds.

Fusing unit pressure adjusting levers

When feeding envelopes from the multi purpose drawer, damage to the envelopes or smudges on prints may occur even if envelopes within specification are used. In this case, the problem may be reduced by shifting the fusing unit pressure adjusting levers from the normal position to the lower pressure position. Follow the procedure below.

NOTE

Be sure to return the lever to the normal position when finished feeding envelopes. If not, inadequate toner adherence, paper misfeeds or other trouble may occur.

1 Unlatch the duplex module and slide it to the left.

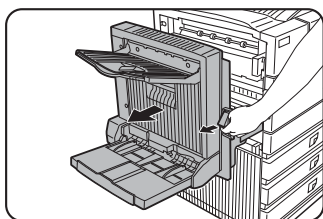

Unlatch the module and gently move the module away from the machine. If the machine is not equipped with a duplex module, open the side cover similarly.

3 Gently close the duplex module.

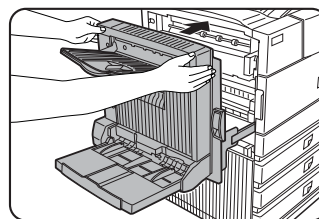

If the machine is not equipped with a duplex module, close the side cover.

2 Lower the two fusing unit pressure adjusting levers marked A and B in the illustration.

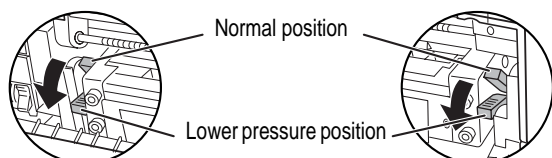
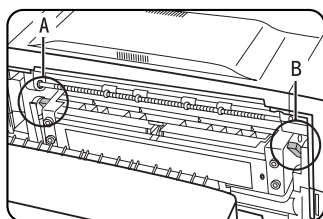

A: Rear side of fusing unit

B: Front side of fusing unit

■ Loading transparency film

Be sure to load the transparency film with the white label side up. Make sure no image will be printed on the label. Printing on the label may cause smudges on prints. Transparency film must be set in the portrait orientation.

Specifications (multi purpose drawer)

Name	Multi purpose drawer
Paper size/weight	See specifications of paper trays on page 2-3.
Paper capacity	500 sheets (80 g/m ² (20 lbs.)) of paper, 40 envelopes, 40 postcards, 40 sheets of transparency film
Dimensions	654 mm (W) x 567 mm (D) x 144 mm (H) (25-3/4" (W) x 22-21/64" (D) x 5-43/64" (H))
Weight	Approximately 11 kg or 24.3 lbs.

Specifications are subject to change for improvement without notice.

Loading paper in the stand/3 x 500 sheet paper drawer

Upper paper tray:

The upper tray is the same as the multi-purpose drawer. Use the upper tray according to the instructions for the multi-purpose drawer on page 2-8.

Middle and lower paper trays:

Up to 500 sheets of Olivetti recommended plain paper can be loaded in these trays. The method of loading paper is the same as for paper tray 1 in the main unit. See the description (page 2-2).

NOTE

If the paper size or paper type is changed in either paper tray, the tray settings must be changed in custom settings. Refer to "Setting the paper type and paper size" on page 2-5.

Specifications (stand/3 x 500 sheet paper drawer)

Name	Stand/3 x 500 sheet paper drawer
Paper size/weight	See specifications of paper trays on page 2-3.
Paper capacity (ordinary paper)	500 sheets (80 g/m ² (20 lbs.) each
Dimensions	589 mm (W) x 630 mm (D) x 404 mm (H) (23-3/16" (W) x 24-51/64" (D) x 15-29/32" (H))
Weight	Approximately 32.9 kg or 70.6 lbs.

Loading paper in the stand/MPD & 2000 sheet paper drawer

Upper paper tray:

The upper paper tray is equivalent to the multi purpose drawer. The method of loading paper and the paper that can be used are the same as for the multi purpose drawer. Refer to the description of the multi purpose drawer (see page 2-8).

Lower paper tray:

The lower paper tray is a large capacity tray that holds 2,000 sheets of A4 or 8-1/2" x 11" paper (80 g/m² (20 lbs.)). Use the following procedure to load paper in the large capacity tray.

NOTE

If the paper size or paper type is changed in either paper tray, the tray settings must be changed in custom settings. Refer to "Setting the paper type and paper size" on page 2-5.

1 Pull out the large capacity tray.

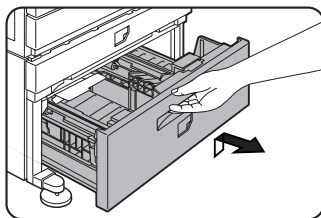

Gently pull the tray out until it stops.

3 Gently push the large capacity paper tray into the machine.

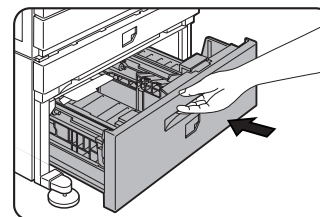

Push the tray firmly all the way into the machine.

2 Load paper onto the right and left paper feed tables.

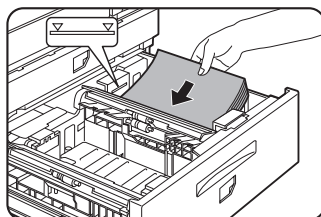

Load paper onto the right paper feed table. The right table holds approximately 1,200 sheets.

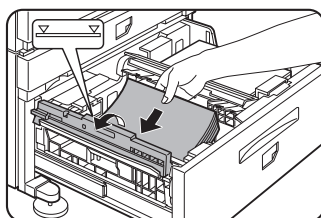

Raise the paper guide and load paper onto the left paper feed table. The left table holds approximately 800 sheets. After loading paper, be sure to return the paper guide.

4 Set the paper type.

If you have changed the paper size from the AB system to the inch system or vice versa, select the relevant type referring to "Setting the paper type and paper size" on page 2-5.

5 Loading paper in the stand/MPD & 2000 sheet paper drawer is now complete.

Specifications (stand/MPD & 2000 sheet paper drawer)

Name	Stand/MPD & 2000 sheet paper drawer
Paper size/weight	See specifications of paper trays on page 2-3.
Paper capacity (ordinary paper)	Upper tray: 500 sheets (80 g/m ² (20 lbs.)), Lower tray: 2,000 sheets (80 g/m ² (20 lbs.))
Dimensions	589 mm (W) x 630 mm (D) x 404 mm (H) (23-3/16" (W) x 24-51/64" (D) x 15-29/32" (H))
Weight	Approximately 34 kg or 75 lbs.

CUSTOM SETTINGS

The items that can be set with the custom settings are shown below.

- Total count The number of pages processed by the machine and optional equipment can be displayed. (See page 2-14)
- Default settings Used to configure the screen contrast, date and time, and keyboard selection*1 settings. (See page 2-14)
- List print Used to print lists of settings and fonts. (See page 2-14)
- Paper tray settings The paper type, paper size and automatic tray switching can be set for each tray. Automatic tray switching allows feeding to switch between trays loaded with the same type and size of paper. If one tray runs out of paper during printing, printing will continue from the other tray. (See page 2-14)

For the detailed descriptions and use of the settings listed below, see the fax, network scanner, and printer manuals.

- Address control*1 Used to store information for various functions.
- Sender control*2 Used to program the sender's information that appears on your Scan to E-mail transmissions at the destination.
- Fax data*1 receive/forward Faxes received to memory and received Internet faxes can be forwarded to another destination.
- Printer condition*3 Used to configure default settings for the printer function (see the Operation manual (for printer)).
- Document filing control*4 Used to configure default settings for the document filing function. (pages 7-21 to 7-25)
- Key operator programs. These are programs that are used by the key operator (administrator of the machine) to configure machine settings. A key appears for these settings in the custom settings menu screen. For information on these settings, see the key operator's guide.

*1 These settings can be configured in a system where the facsimile or network scanner function is available.

*2 These settings can be configured in a system where the network scanner function is available.

*3 These settings can be configured in a system where the printer function is available.

*4 These settings can be configured in a system where the document filing function is available.

General procedure for custom settings

1 Press the [CUSTOM SETTINGS] key.

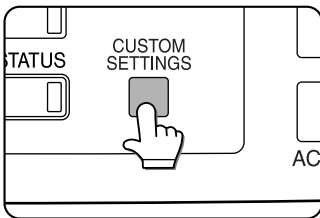

The custom settings menu screen will appear.

2 Touch the key of the desired item to display its setting screen.

The example of selecting the [DEFAULT SETTINGS] key and then the [CLOCK] key is explained below.

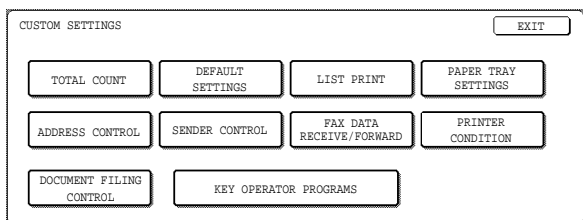

Detailed descriptions for program settings start on the next page.

3 Touch the [CLOCK] key.

Touch the [CLOCK] key and then the following screen appears.

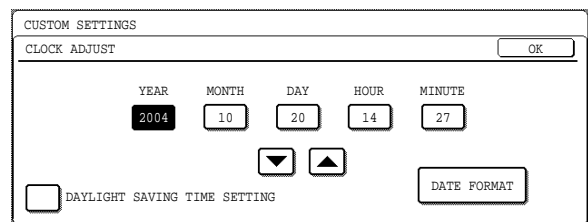

4 Touch the year, month, day, hour or minute key, and then use the ▲ or ▼ key to adjust the setting.

- If you select a non-existent date (for example, Feb. 30), the [OK] key will grey out to prevent entry of the date.
- Select [DAYLIGHT SAVING TIME SETTING] checkbox to have the time automatically change at the beginning and end of daylight saving time.

5 Touch the [DATE FORMAT] key.

The following screen appears.

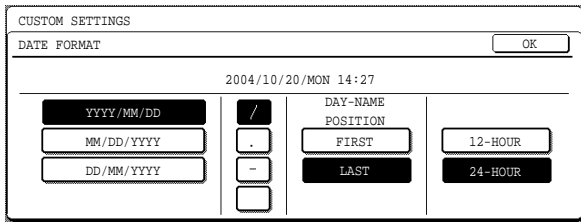

6 If you wish to change the format of the date and time, touch the desired format keys.

Touched keys are highlighted.
The selected format is applied to lists printed out in "LIST PRINT".

7 Touch the [OK] key.

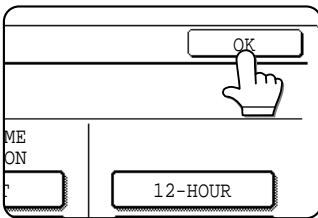

You will return to the date and time setting screen.

8 Touch the [OK] key.

9 To exit the settings, touch the [EXIT] key.

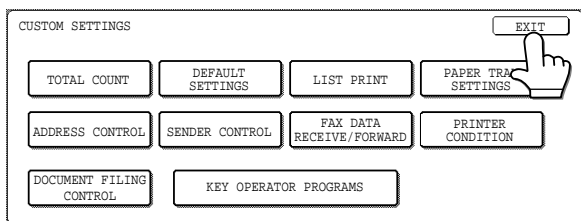

More information on setting procedures

In the following type of screen, a setting is selected by touching the key so that a checkmark (☑) appears. The settings below are configured to allow use of tray 1 in print, copy, and fax modes. To display the next screen, touch the ⬇️ or ⬆️ keys.

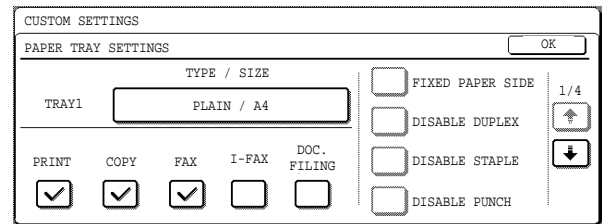

2

About the settings

■ Total count

This displays the following sheet counts (the counts that can be displayed vary depending on the options installed):

- (1) Number of pages output by the machine.
- (2) Number of original pages transmitted by the machine.
- (3) Number of times the automatic document feeder was used to feed original pages and number of times the stapler was used (if installed).
- (4) Number of pages stored by document filing.

In the case of (1) only,

- A3 (11" x 17") size paper is counted as two sheets.
- Each sheet of paper used for automatic two-sided copying is counted as two sheets (A3 (11" x 17") paper is counted as four sheets).
- Paper with an entered size of 384 mm (15-1/8") or larger is counted as two sheets (four sheets during automatic two-sided copying).

■ Default settings

The following settings can be configured:

- Display contrast
Screen contrast adjustment is used to make the LCD touch panel easier to view under various lighting conditions. Touch the [LIGHTER] key to make the screen lighter, or the [DARKER] key to make the screen darker.
- Clock
Use this to set the date and time in the machine's built-in clock. This clock is used by functions that require date and time information.
- Keyboard select
The layout of the keyboard that appears in letter entry screens can be changed. Select the arrangement of the letter keys that you find easiest to use.

The following three alphabet keyboard configurations are available:

- Keyboard 1 (QWERT... configuration)*
- Keyboard 2 (AZERTY...configuration)
- Keyboard 3 (ABCDEF...configuration)

* The default setting is "Keyboard 1".

(Example: Character entry screen when Keyboard 3 is selected)

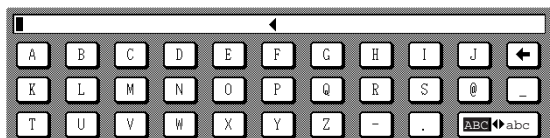

■ List print

This is used to print lists of machine settings and a test page to check resident fonts.

The following lists and pages are available:

- All custom setting list
Shows the hardware status, software status, printer configuration settings, tray settings, and counts.
- Printer test page
Shows the PCL symbol set list, fonts, network interface (NIC interface) settings, and settings used for the NIC card.
- Sending address list
One touch destination list, group list, program list, and memory box list.
- Document filing user / folder list
Shows the user names and folder names for document filing.
- Sender control list
Shows the senders that have been stored.

NOTE

A test page cannot be printed if "PROHIBIT TEST PAGE PRINTING" (See the "Operation manual (for printer)".) has been set to "prohibited" in the key operator programs.

■ Paper tray settings

The paper type, paper size, enabled modes and automatic tray switching can set for each tray. See page 2-5 to 2-7 for details on setting the paper type and paper size. Automatic switching to another paper tray is used to automatically switch to another tray with the same size and type of paper in the event that the paper runs out during continuous printing. This requires that the trays be loaded with the same size of paper. The paper tray settings can be enabled or disabled for each tray, and for printer mode, copy mode, fax mode, Internet fax mode, and document filing mode. To enable any function, touch the check box key so that a checkmark (☑) appears.

REPLACING THE TONER CARTRIDGE

When toner runs low, a message will appear to inform you that the toner cartridge must be replaced.

NOTE

To view the approximate amount of toner remaining, hold down the [COPY] key during printing or when the machine is on standby. The percentage of toner remaining will appear in the display while you hold down the key. When the percentage falls to "25-0%", obtain a new toner cartridge and keep it ready for replacement.

Follow the steps below to replace the toner cartridge.

1 Open the front cover.

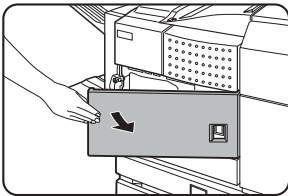

2 Lower the cartridge lock lever.

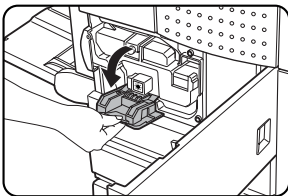

3 While depressing the lock release button, pull out the toner cartridge and remove it.

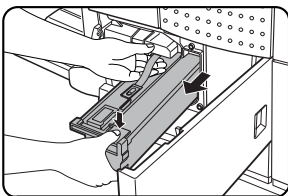

4 Remove a new toner cartridge from the package and shake it horizontally five or six times.

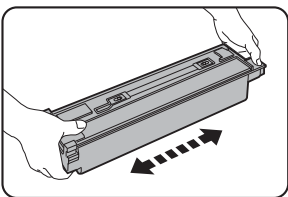

NOTE

Shake the toner cartridge well to ensure that the toner flows well and will not stick to the inside of the cartridge.

5 Insert a new toner cartridge.

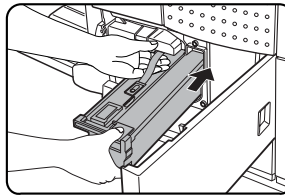

Push the cartridge in until it locks securely into place.

2

6 Gently remove the sealing tape from the cartridge.

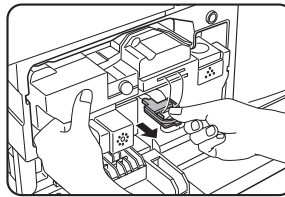

Once the seal is pulled out, the toner in the toner cartridge is supplied to the developer cartridge.

7 Return the cartridge lock lever.

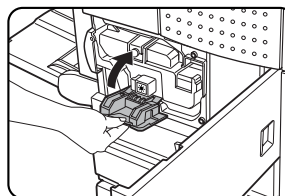

8 Close the front cover.

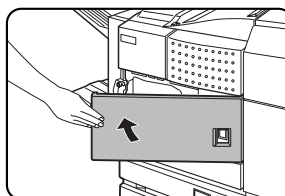

CAUTION

- Do not throw the toner cartridge into a fire. Toner may fly and cause burns.
- Store toner cartridges out of the reach of small children.

NOTE

Place the used toner cartridge in the plastic bag and store it. When placing the toner cartridge in the bag, insert it horizontally, not vertically. If the cartridge is stood on end, the collected used toner may spill out and soil the floor or your clothes.

STORAGE OF SUPPLIES

Standard supplies for this product that can be replaced by the user include paper, toner cartridges, and staple cartridges for the finisher.

olivetti

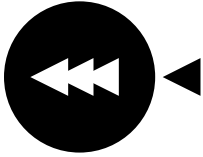

For best copying results, be sure to use only Olivetti Genuine Supplies which are designed, engineered, and tested to maximize the life and performance of Olivetti products. Look for the Genuine Supplies label on the toner package.

GENUINE SUPPLIES

■ Proper storage

1. Store the supplies in a location that is:
 - clean and dry,
 - at a stable temperature,
 - not exposed to direct sunlight.
2. Store paper in the wrapper and lying flat.
3. Paper stored in packages standing up or out of the wrapper may curl or become damp, resulting in paper misfeeds.
4. Store a new toner cartridge box horizontally. Do not store it standing on end. If stored standing on end, the toner may not distribute well even after shaking the cartridge vigorously, and will remain inside the cartridge without flowing out.

Supply and Consumables

The supply of spare parts for a repair of the appliance is guaranteed for at least 7 years following the termination of production. Spare parts are those parts of the apparatus which may break down within the scope of the ordinary use of the product - whereas those parts which normally exceed the life of the product are not to be considered as spare parts. Consumables too, are available for 7 years following the termination of production.

MISFEED REMOVAL

When a misfeed has occurred during printing, the message "A MISFEED HAS OCCURRED". will appear in the touch panel display of the operation panel and printing including copying and facsimile output will stop. The approximate misfeed locations are indicated with "▼" shown in the illustration below. The page numbers for detailed information on misfeed removal are also shown.

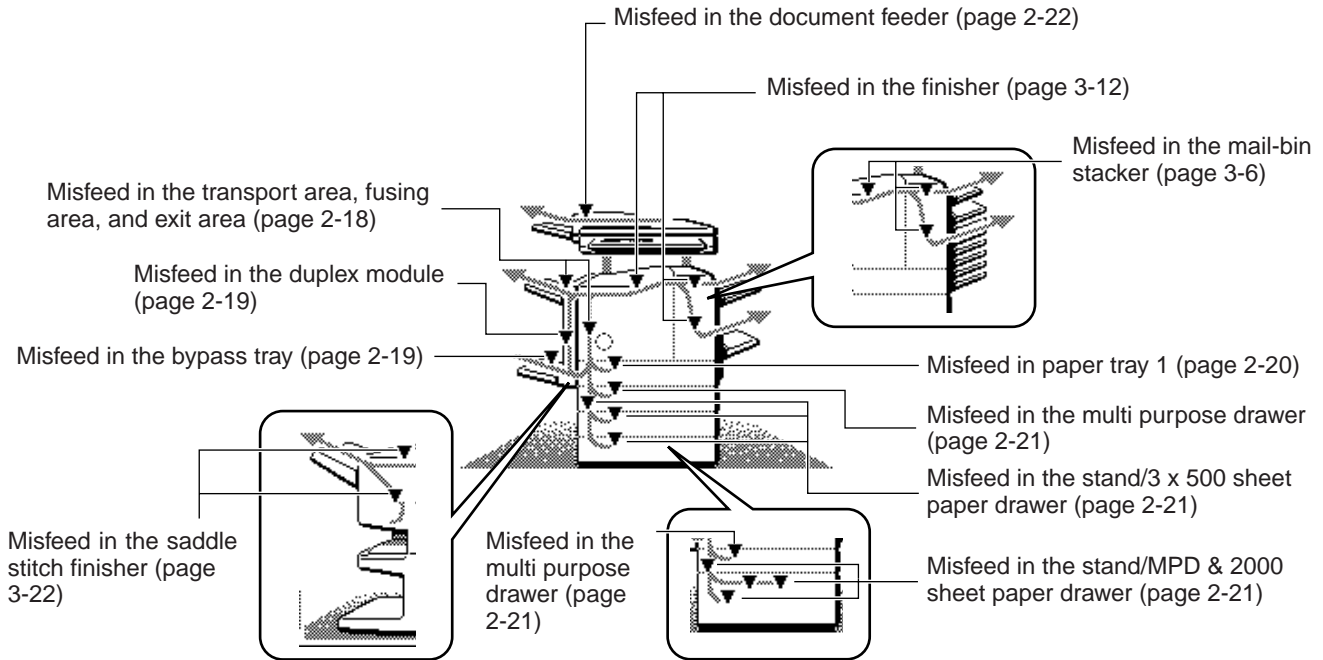

NOTE
 Printing is not possible when a misfeed occurs, and thus any faxes or Internet faxes received at this time will be temporarily held in memory. The faxes will print out automatically as soon as the misfeed is cleared.

- NOTES**
- Do not damage or touch the photoconductive drum. (See page 2-18.)
 - Be careful not to tear the misfed paper during removal.
 - If paper is accidentally torn during removal, be sure to remove all pieces.

CAUTION

The fusing unit is hot. Take care in removing paper.

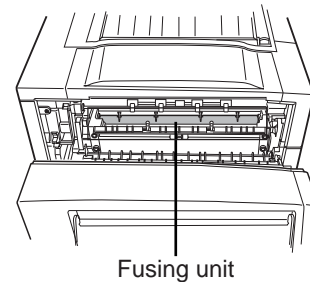

Misfeed removal guidance

Misfeed removal guidance can be displayed by touching the [INFORMATION] key on the touch panel after a misfeed has occurred.

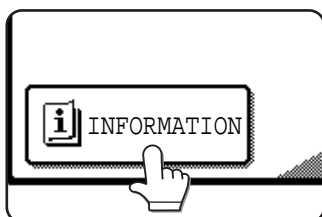

Misfeed in the transport area, fusing area, and exit area

CAUTION

The fusing unit is hot. Take care in removing paper. (Do not touch the metal parts.)

1 Unlatch the duplex module and slide it to the left.

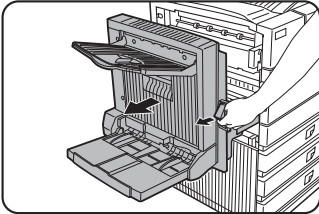

Unlatch the module and gently move the module away from the machine. If the machine is not equipped with a duplex module, open the side cover similarly.

2 Remove the misfed paper as shown in the illustrations below.

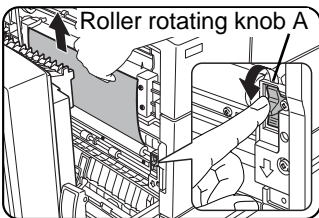

If paper is misfed in the transport area, turn roller rotating knob A in the direction of the arrow to remove the misfed paper.

NOTE

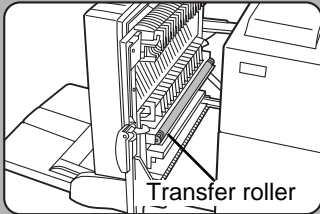

Do not touch or damage the transfer roller.

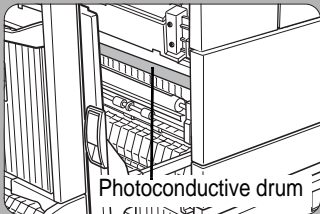

Do not touch or damage the photoconductive drum.

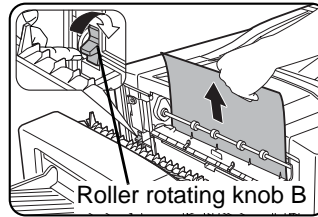

If paper is misfed in the fusing area, turn roller rotating knob B in the direction of the arrow to remove the misfed paper.

CAUTION

The fusing unit is hot. Take care in removing paper. (Do not touch any metal parts.)

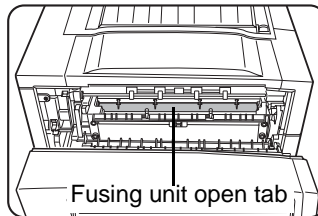

If the misfed paper is inside the fusing area, turn down the fusing unit open tab to open the fusing unit and remove the misfed paper.

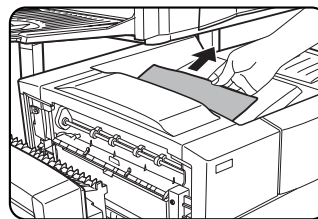

If paper is misfed in the exit area, remove it as shown while taking care not to tear the paper.

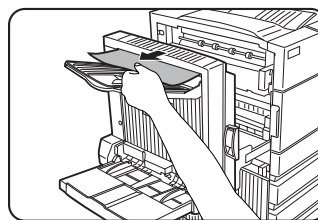

If the duplex module is equipped with an exit tray and paper is misfed in the exit area, remove the misfed paper as shown in the illustration.

3 Gently close the duplex module.

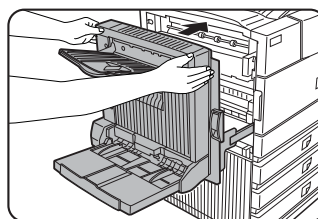

If the machine is not equipped with a duplex module, close the side cover.

After closing, confirm that the misfeed message is cleared and the normal display appears.

Misfeed in the duplex module

- 1** Unlatch the duplex module and slide it to the left.

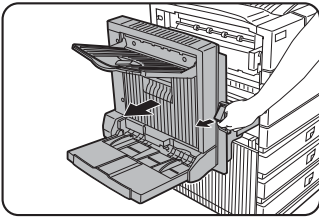

Unlatch the unit and gently move the module away from the machine.

- 2** If the duplex module has an exit tray, rotate it up out of the way and open the cover of the duplex module.

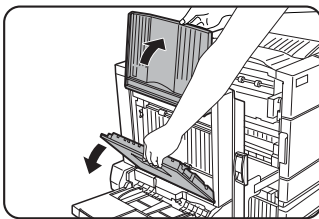

If no exit tray is attached, just open the cover of the duplex module and ignore any reference to the tray in the following steps.

- 3** While holding the exit tray up, remove the misfed paper as shown in the illustrations below.

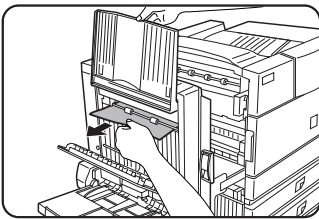

If paper is misfed at the upper part of the duplex module, gently remove it while taking care not to tear the paper.

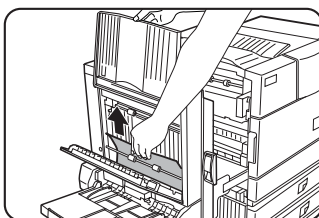

If paper is misfed at the lower part of the duplex module, gently remove it while taking care not to tear the paper.

- 4** Close the cover of the duplex module and lower the exit tray.

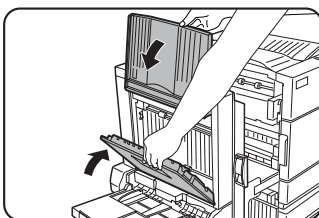

- 5** Gently close the duplex module.

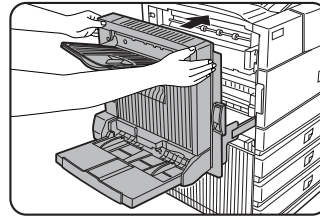

After closing the duplex module, confirm that the misfeed message is cleared and the normal display appears.

2

Misfeed in the bypass tray

- 1** Unlatch the duplex module and slide it to the left.

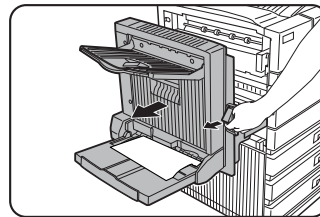

Unlatch the unit and gently move the module away from the machine.

- 2** Remove the misfed from the bypass tray.

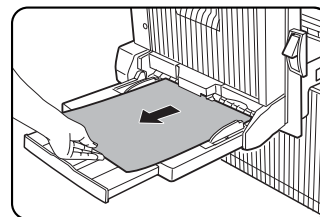

Be careful not to tear the misfed paper during removal.

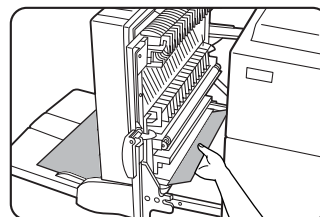

- 3** Gently close the duplex module.

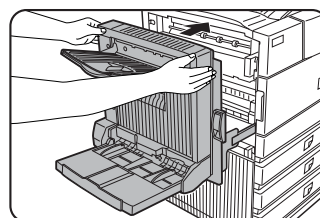

After closing the duplex module, confirm that the misfeed message is cleared and that the normal display appears.

Misfeed in the paper feed area

NOTE

Be sure to follow the misfeed removal sequence. Do not pull the tray out immediately as the misfeed may have occurred with paper partially fed out of the tray. Open the left cover and see if there is misfed paper first (steps 1 and 2). If you open the tray without checking, the partially fed paper may tear and leave torn pieces in the machine, increasing the difficulty of removal.

■ **Misfeed in paper tray 1**

1 Unlatch the duplex module and slide it to the left.

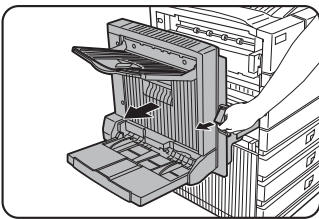

Unlatch the module and gently move the module away from the machine. If the machine is not equipped with a duplex module, open the side cover similarly.

2 Remove the misfed paper.

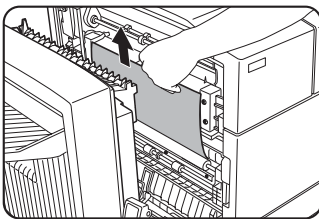

Be careful not to tear the misfed paper during removal.

NOTE

The paper may not be extending out far from inside the machine but must be removed if it is possible to grasp it. If it is not possible to grasp it, go to the next step.

3 If misfed paper is not found in step 2, pull out paper tray 1 and remove the misfed paper.

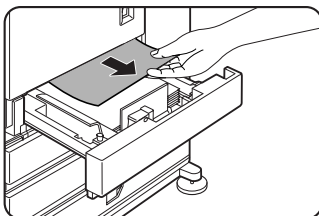

Be careful not to tear the misfed paper during removal.

4 Gently close the paper tray.

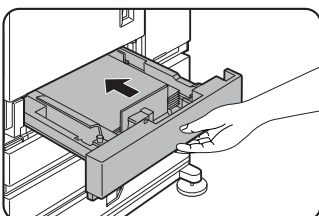

Push the paper tray back into the machine.

5 Gently close the duplex module.

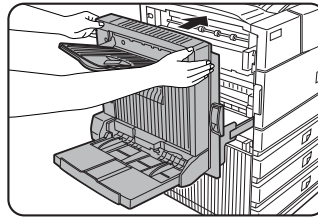

If the machine is not equipped with a duplex module, close the side cover.

After closing, confirm that the misfeed message is cleared and the normal display appears.

NOTE

If paper drops beyond the rear side of the paper tray that has been pulled out, remove the paper tray and then remove the paper. (For removal of the paper tray, see the illustration below.)

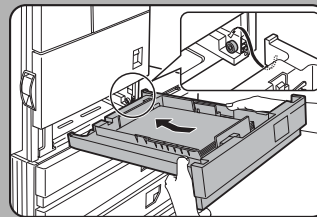

After pulling out the paper tray until it stops, gently lift and pull the tray to remove it. To reinstall the paper tray, insert it at an angle and then push it into the machine.

To remove a paper tray from a stand/paper drawer, pull the tray out until it stops then rotate it to the left to disengage it from the stand. When reinstalling it, place the left rear of the drawer into the slot and rotate the drawer to the right and into the stand.

Installation of trays in the stand/3x500 sheet paper drawer

The middle and lower trays cannot be installed in the upper tray position and the upper tray cannot be installed to the middle and lower tray positions. (These cannot be pushed into the machine.)

Take care not to install a tray to an improper position after removing the tray.

■ Misfeed in the multi purpose drawer

1 Unlatch the duplex module and slide it to the left.

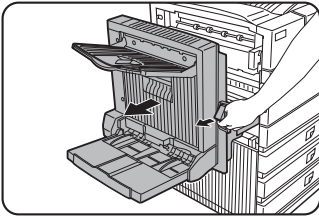

Unlatch the module and gently move the module away from the machine. If the machine is not equipped with a duplex module, open the side cover similarly.

2 Open the left cover of the stand/paper drawer.

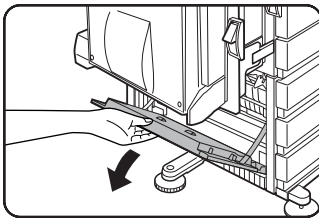

Hold the knob and gently open the cover. If the machine is not equipped with a stand/paper drawer, open the left cover of the multi purpose drawer.

3 Remove the misfed paper.

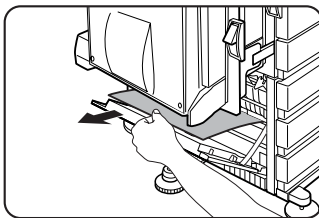

Be careful not to tear the misfed paper during removal.

NOTE
The paper may not be extending out far from inside the machine but must be removed if it is possible to grasp it. If it is not possible to grasp it, go to the next step.

4 Close the left cover of the stand/paper drawer.

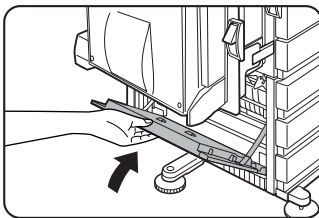

5 Gently close the duplex unit.

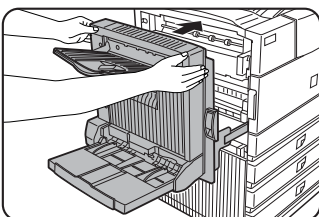

If the machine is not equipped with a duplex module, close the side cover. After closing, confirm that the misfeed message has been cleared and the normal display appears.

6 If misfed paper is not found in step 3, refer to "Misfeed in paper tray 1" (steps 1 to 5 on the previous page) to remove the misfed paper.

■ Misfeed in the stand/3 x 500 sheet paper drawer

For misfeed removal in the upper tray, follow the procedure of "Misfeed in the multi purpose drawer" shown to the left to remove the misfed paper.

■ Misfeed in the stand/MPD & 2000 sheet paper drawer

For misfeed removal in the upper tray, follow the procedure of "Misfeed in the multi purpose drawer" shown to the left to remove the misfed paper. For misfeed removal in the lower large capacity tray, follow the procedure below.

1 Follow steps 1 to 4 of "Misfeed in the multi purpose drawer" shown to the left.

2 If misfed paper is not found in step 1, refer to "Misfeed in paper tray 1" on the previous page.

3 If misfed paper is not found in steps 1 and 2, pull out the large capacity tray (lower tray) and remove the misfed paper as shown in the illustrations below.

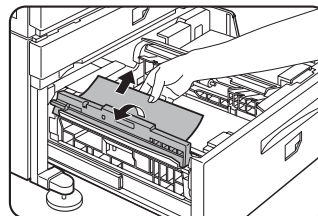
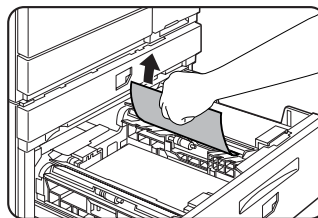
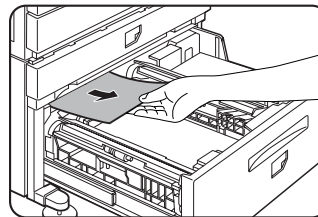

Raise the paper guide and remove the misfed paper. After removing the misfed paper, be sure to return the paper guide.

4 Gently close the large capacity tray.

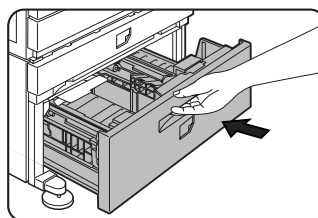

Push the paper tray all the way into the machine.

5 Gently close the duplex module.

If the machine is not equipped with a duplex module, close the side cover. After closing, confirm that the misfeed message has been cleared and the normal display appears.

REMOVING AN ORIGINAL MISFEED

Removing a misfed original from the automatic document feeder

If an original misfeed occurs in the automatic document feeder, follow the steps below to remove the misfed original.

NOTES

- For misfeed removal in the main unit and other peripheral devices, see page 2-17
- When a misfeed occurs, touch the [INFORMATION] key to display detailed information for misfeed removal.

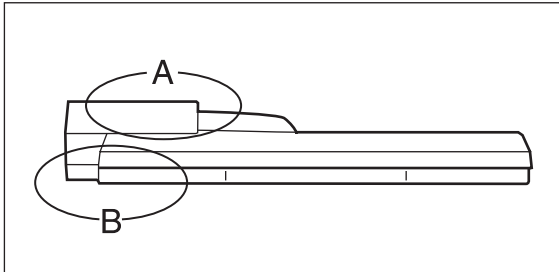

Check locations A and B in the diagram at left to remove the original.

1 Removing misfeeds from each location.

● Check location A

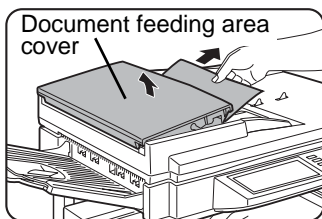

Open the document feeding area cover and gently remove the misfed original without tearing it.

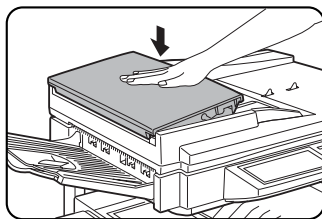

Close the cover securely so that cover clicks into place.

● Check location B

● Misfeed in the transfer unit

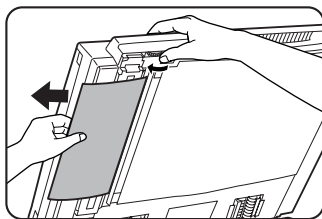

Open the document feeder and turn the green rotating knob in the direction of the arrow to remove any misfed originals.

2 Open and close the document feeder.

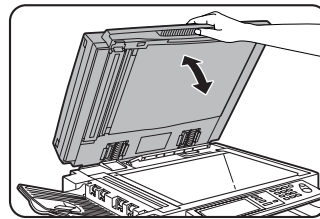

Opening and closing the cover clears the misfeed display. Copying cannot be resumed until this step is performed.

However, this step is not necessary after a misfeed is removed from location B.

A message may appear indicating the number of originals which must be returned to the document feeder tray. Return the originals to the document feeder tray and press the [START] key.

TROUBLESHOOTING

Check the following troubleshooting list before requesting service as many problems can be fixed by the user. If you are unable to solve the problem by checking the list, turn off the power switch, unplug the power cord. Problems related to general use of the machine are described below. For problems related to the copy function, see page 6-3. For problems related to document filing, see page 7-28. For fax, printer, and network scanner problems, see the manuals for those functions. For peripheral device problems, see the explanation of the device.

If the message "CALL FOR SERVICE. CODE:**-**"^(Note) appears in the touch panel, turn off the power switch, wait about 10 seconds, and then turn the power switch back on. If the message still appears after turning the power switch off and on several times, it is likely that a failure has occurred that requires service. In this event, stop using the machine, unplug the power cord, and contact your Olivetti dealer.
 Note: Letters and numbers appear in "**-**". When you contact your Olivetti dealer, please tell your dealer what letters and numbers appear.

Problem	Check	Solution or cause
The machine does not operate.	Machine plugged in?	Plug the machine into a grounded outlet.
	The power switch are not turned on?	Turn on the power switch. (Page 1-17)
	READY indicator off?	The machine is warming up. (Warm-up time is approximately 80 seconds.) Wait until the READY indicator lights up.
	Message indicating need to load paper displayed?	Load paper. (Page 2-2)
	Message indicating need to replace the toner cartridge displayed?	Replace the toner cartridge. (Page 2-15)
	Message indicating a paper misfeed displayed?	Remove misfed paper. (Page 2-17)
Copying/printing is not possible	A message appears saying that this type of paper cannot be used for two-sided copying.	Two-sided printing is not possible on special paper. Use paper that can be used for automatic two-sided printing. (Page 2-4)

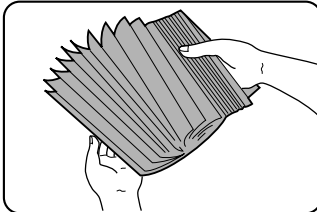
Problem	Check	Solution or cause
Printing stops before the job is finished	If too many pages collect on the output tray, the tray full sensor activates and stops printing.	Remove the paper from the output tray.
	You have run out of paper.	Load paper. (Page 2-2)
Smudges on printed sheets	Does a message appear indicating the need for maintenance?	Please contact the your dealer as soon as possible.
The displayed paper size or paper type does not match the loaded paper size or paper type.	The correct paper size or paper type is not set in the paper tray settings of the custom settings.	When loading paper, if you change the paper size from an inch size to an AB size, or from an AB size to an inch size, or change the paper type, be sure to set the new paper type as explained in "Setting the paper type and paper size" (see page 2-5).
When printing on a special size of paper, part of the printed image is missing.	The paper size setting is not set correctly in the paper tray settings of the custom settings.	When using a special size of paper, set the correct paper size as explained in "Setting the paper type and paper size" on page 2-5. If the paper size setting is not correct, part of the image may be cut off or the image may not print.
Paper misfeeds frequently.	Is paper other than Olivetti-recommended paper being used?	Use Olivetti-recommended paper. (Page 2-16)
	Paper curled or damp?	Do not use curled or crimped paper. If you will not use the paper for a long time, remove the paper from the tray and store it in the wrapper in a cool and dark location so that it will not absorb moisture.
	Is the paper curled and does it frequently misfeed in the finisher or saddle stitch finisher?	Paper may be curled when output depending on the paper type and quality. In some cases turning the paper over in the tray will reduce misfeeding due to curling.
	Multiple sheets of paper fed simultaneously?	 <p>Remove the paper from the paper tray or the bypass tray, fan the paper as shown in the illustration, and then load it again.</p>
	The paper in the tray is not stacked evenly.	Make sure that the paper in the paper tray is stacked evenly. If the stack is not even, paper misfeeds will occur.

Problem	Check	Solution or cause
Printed paper is wrinkled or the image rubs off easily.	Is paper other than Olivetti-recommended paper being used?	Use Olivetti-recommended paper. (Page 2-16)
	Is paper size or weight out of the allowable range?	Use paper in the allowable range.
	Paper damp?	Be sure to store paper in the wrapper in a dry location and do not store paper in a location that is <ul style="list-style-type: none"> ● humid ● at a high temperature or an extremely low temperature ● exposed to direct sunlight ● dusty.
The contrast on the touch panel is too high or too low.	Is LCD contrast properly adjusted?	Adjust the screen contrast using "DISPLAY CONTRAST" in "Default settings" of the custom settings. (Page 2-14)
Printing takes place on the wrong side of the paper.	The paper is loaded in the tray with the print side face down*. *Face up if the paper type is "PRE-PRINTED", "PRE-PUNCHED" or "LETTER HEAD".	Load paper in the tray with the print side face up. However, if the paper type is "PRE-PRINTED", "PRE-PUNCHED" or "LETTER HEAD", load the paper with the print side face down*. * If the two-sided function has been prohibited using "DISABLING OF DUPLEX" in the key operator programs (page 11 of the Key operator's guide), load the paper face up.
Marks appear at regular intervals on printed pages.	Paper with punch holes is being used.	If the original image overlaps the punch holes, marks will appear at the position of the holes on the back of the paper after one-sided printing, or on the front and back of the paper after two-sided printing. Make sure that the original image does not overlap the punch holes.



CHAPTER 3

PERIPHERAL DEVICES

This chapter describes operating instructions for the Mail-Bin Stacker, the Finisher, the Saddle Stitch Finisher, and the Duplex Module.

	Page
DUPLEX MODULE	3-2
• Part names.....	3-2
• Specifications.....	3-2
• Loading paper in the bypass tray.....	3-3
• Troubleshooting (concerning the duplex module).....	3-4
MAIL-BIN STACKER	3-5
• Part names.....	3-5
• Specifications.....	3-5
• Misfeed in the mail-bin stacker.....	3-6
FINISHER	3-7
• Part names.....	3-7
• Specifications.....	3-7
• Finisher functions.....	3-8
• Using the finisher functions.....	3-9
• Staple cartridge replacement.....	3-10
• Misfeed in the finisher.....	3-12
• Troubleshooting finisher problems.....	3-13
SADDLE STITCH FINISHER.....	3-14
• Part names.....	3-14
• Specifications.....	3-14
• Saddle stitch finisher functions.....	3-15
• Using the saddle stitch finisher.....	3-18
• Staple cartridge replacement and staple jam removal.....	3-19
• Misfeed in the saddle stitch finisher.....	3-22
• Troubleshooting (concerning the saddle stitch finisher).....	3-24

DUPLEX MODULE

If a duplex module is installed, printing onto both sides of paper can be performed.

Two types of duplex modules are available: duplex module/bypass tray and duplex module. The descriptions in this manual are for the duplex module/bypass tray. For information on misfeed removal for these modules, see page 2-19.

Part names

Exit tray

The tray is extendable to support large size paper. Extend the tray when A3, B4, 11" x 17", 8-1/2" x 14" or 8-1/2" x 13" paper is being used. For a duplex module (not duplex module/bypass tray), the exit tray is optional.

Bypass tray

This tray can also be used for special papers including transparency film. (See next page and page 2-3.)

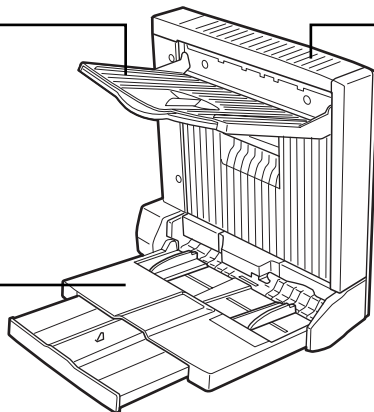

Duplex module

Automatic copying on both sides of the paper is possible.

NOTE

Automatic two-sided printing can be done only onto plain paper. Special papers cannot be used for two-sided printing. (See page 2-4 for explanation on special paper.)

NOTES

- Do not press down on the bypass tray or the exit tray.
- The duplex module requires the installation of other peripheral devices in order to be functional and cannot be installed together with some other devices. The table on page 8-4 shows the configurations which are compatible.

Specifications

Name	Duplex module (AR-DU3) or Duplex module/bypass tray (AR-DU4)
Paper size (for duplex copy)* ¹	A3, B4, A4, A4R, B5, B5R, A5R, 11" x 17", 8-1/2" x 14", 8-1/2" x 13", 8-1/2" x 11", 8-1/2" x 11"R, 5-1/2" x 8-1/2" R
Paper weight (for duplex copy)* ¹	60 to 105 g/m ² or 16 to 28 lbs.
Reference paper position	Centre
Bypass tray paper capacity* ²	100 sheets (A4 or 8-1/2" x 11" size, 80 g/m ² or 20 lbs.)
Dimensions	Duplex module: 115 mm (W) x 412 mm (D) x 416 mm (H) (4-17/32" (W) x 16-15/64" (D) x 16-25/64" (H)) Duplex module/bypass tray* ³ : 441 mm (W) x 436 mm (D) x 416 mm (H) (17-23/64" (W) x 17-11/64" (D) x 16-25/64" (H))
Weight	Duplex module: Approx. 5 kg (11.1 lbs.) Duplex module/bypass tray: Approx. 7.5 kg (16.6 lbs.)

*¹ For paper size and paper weight for the bypass tray, see "Specifications of paper trays (types and sizes of applicable papers for trays)" on page 2-3.

*² Duplex module/bypass tray only.

*³ When the bypass tray extension is extended.

Name	Exit tray (AR-TE3)
Paper output	Print face down
Paper capacity	100 sheets (A4 or 8-1/2" x 11" size, 80 g/m ² or 20 lbs.)
Paper size	Max. A3 or 11" x 17", Min. A5R or 5-1/2" x 8-1/2"R
Paper type and weight to be output	Plain paper, 60 to 105 g/m ² or 16 to 28 lbs. Heavy paper, 106 to 205 g/m ² or 29 to 110 lbs.

Specifications are subject to change for improvement without notice.

Loading paper in the bypass tray

The bypass tray can be used for plain paper and special paper including labels. Up to 100 sheets of standard paper can be set. For paper types that can be used in the bypass tray, refer to page 2-3.

NOTE

If the paper type or size is changed, be sure to enter the paper type and size as in step 4.

1 Open the bypass tray.

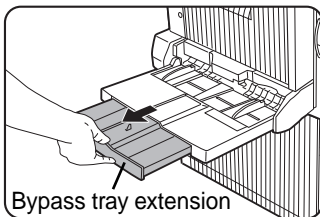
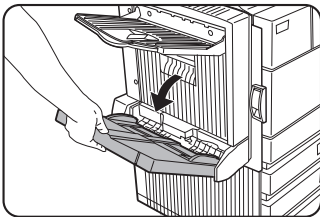

When setting A3, B4, 11"x 17", 8-1/2" x 14" or 8-1/2" x 13 paper, be sure to extend the bypass tray extension. If the bypass tray extension is not pulled all the way out the size of the loaded paper will not be correctly displayed.

2 Set the bypass tray paper guides to the width of the paper to be used.

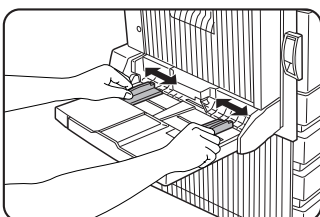

3 Insert the paper all the way into the bypass tray.

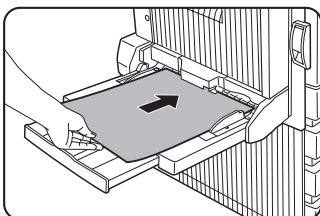

Set the paper face down. If there is a clearance between the paper and the paper guides, the paper may not be fed correctly. Adjust the guides so that they contact the edges of the paper.

NOTES

- When using A5 paper, 5-1/2" x 8-1/2" paper or postcards, be sure to load them with their shorter edge into the feed slot as shown in the illustration.

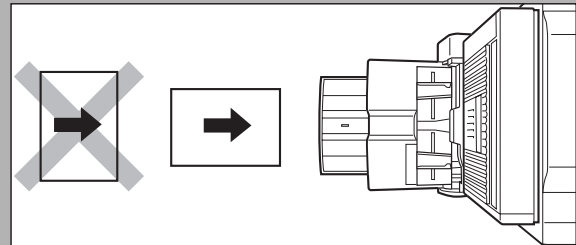

- When loading plain paper other than Olivetti standard paper, special media other than postcards, Olivetti-recommended transparency film, or paper to be printed on the back, the paper must be loaded one sheet at a time. Loading more than one sheet at a time will cause misfeeds.
- When adding paper, remove any paper remaining in the tray, combine it with the paper to be added, and reload as a single stack.
- Do not use paper that has already been printed on by a plain paper fax machine or a laser printer. This may cause printed images to become dirty.
- Do not use paper that has already been printed on by a thermal transfer or inkjet printer. In particular, paper that has been printed on by a thermal transfer printer (such as a word processor that uses a cassette) may cause missing characters and smudges.
- When printing on transparency film, be sure to remove each sheet as it exits the machine. Allowing sheets to stack in the output tray may cause curling.
- Please use Olivetti-recommended transparency film. Place the film in the bypass tray so that it is oriented vertically with the label side face up. If the label side is placed face down, smudging may result.

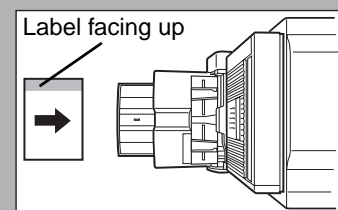

- When loading multiple sheets of transparency film in the bypass tray, be sure to fan the sheets several times before loading.

4 Set the type and size of the loaded paper.

When the paper system is changed from the inch system to the AB system or vice versa or when the paper type is changed, the paper type must be designated. For setting the paper type and paper size, see page 2-5.

5 Loading paper in the bypass tray is now complete.

Troubleshooting (concerning the duplex module)

Check the list below before calling for service.

Problem	Check	Solution or cause
The machine will not print duplex prints.	Message indicating the paper type cannot be used for two-sided printing displayed?	Special paper cannot be used for two-sided printing. Use a paper type adequate for two-sided printing. (See pages 2-4 and 3-2.)
	Message indicating the paper size cannot be used for two-sided printing displayed?	Use a paper size adequate for two-sided printing. (See pages 2-4 and 3-2.)
	Bypass tray extension not extended?	When using A3, B4, 11" x 17", 8-1/2" x 14" or 8-1/2" x 13" paper, the bypass tray extension must be extended.
Printed images onto paper from the bypass tray are skewed.	Does the number of sheets exceed the limit?	Set paper within the allowable range.
	Paper guides properly set?	Set the paper guides properly to the paper size.
A paper misfeed occurs in the bypass tray.	Paper size and type set properly?	When using non-standard size paper or special paper, be sure to set the paper size and type. (See pages 2-3 to 2-5.)
	Does the number of sheets exceed the limit?	Set paper within the allowable range.
	Paper guides properly set?	Set the paper guides properly to the paper size.
When printing on a special size of paper, part of the printed image is missing.	The paper size setting is not set correctly in the paper tray settings of the custom settings.	When using a special size of paper, set the correct paper size as explained in "Setting the paper type and paper size" on page 2-5. If the paper size setting is not correct, part of the image may be cut off or the image may not print.

MAIL-BIN STACKER

The mail-bin stacker has 7 mail bins which can each be designated to receive printed output from a user or a group of users .

Output paper in the copy mode and the fax mode will be delivered to the top tray of the stacker separated from printed output. (Printed output can also be delivered to the top tray.)

Part names

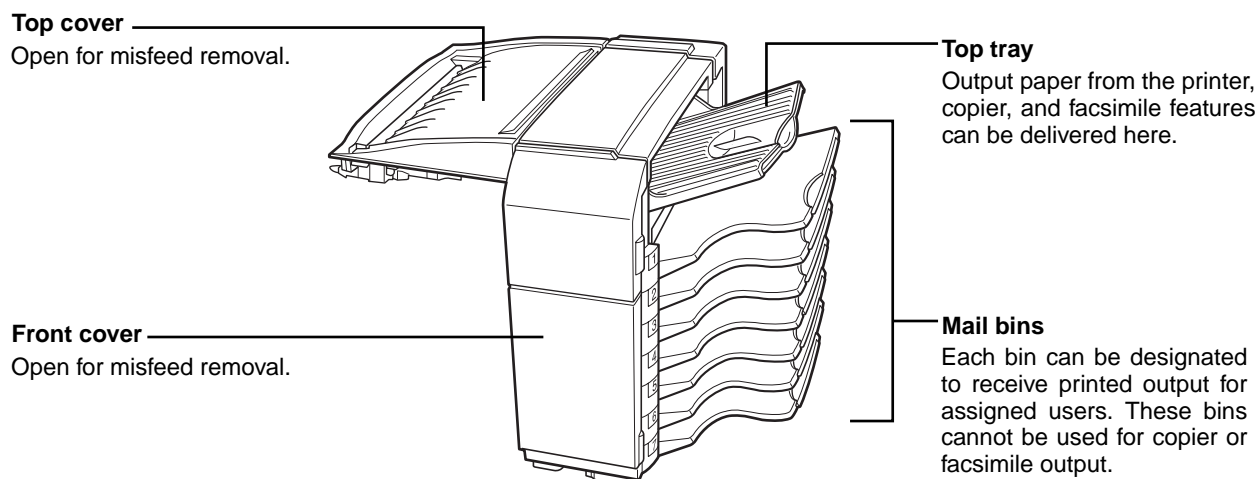

NOTES

- Do not put pressure on the mail-bin stacker, particularly on the top tray and mail bins.
- Do not place anything on the top cover. Doing so will interfere with the machine's paper handling during duplex printing.
- The top tray and each mail bin are extendable. To print onto large paper (A3, B4, 11" x 17", 8-1/2" x 14" or 8-1/2" x 13"), extend the tray.
- The mail-bin stacker requires the installation of other peripheral devices in order to be functional and cannot be installed together with some other devices. The table on page 8-4 shows the configurations which are compatible.

Specifications

Name	Mail-bin stacker (AR-MS1)
Number of trays	8 (Top tray and seven mail bins)
Paper output	Print face down
Tray type	Top tray: normal tray, Mail bins: mail bin tray
Tray capacity	Top tray: 250 sheets (A4 or 8-1/2" x 11" size, 80 g/m ² or 20 lbs.) Mail bins: 100 sheets each (A4 or 8-1/2" x 11" size, 80 g/m ² or 20 lbs.)
Paper sizes	Top tray: same as the specifications of paper for feeding in the main unit Mail bins: A3, B4, A4, A4R, B5, B5R, 11" x 17", 8-1/2" x 14", 8-1/2" x 13", 8-1/2" x 11", 8-1/2" x 11"R, 7-1/4" x 10-1/2"
Paper weight	Top tray: same as the specifications of paper for feeding in the main unit Mail bins: 60 to 105 g/m ² or 15 to 34 lbs.
Paper types	Top tray: same as the specifications of paper for feeding in the main unit Mail bins: plain paper only
Tray full detection	Provided in both the top tray and the mail bins
Power supply	Supplied from machine
Dimensions	503 mm* (W) x 530 mm (D) x 508 mm (H) (19-51/64"* (W) x 20-7/8" (D) x 20" (H)) * When the top tray is extended.
Weight	Approx. 19 kg (41.9 lbs.)

Specifications are subject to change for improvement without notice.

Misfeed in the mail-bin stacker

If a misfeed has occurred in the mail-bin stacker during printing, remove the misfed paper following the procedure below.

1 Open the top cover.

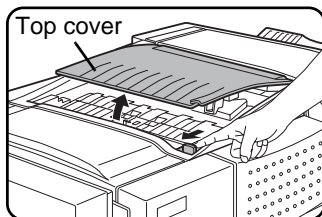

Move the tab in the direction of the arrow as shown in the illustration to open the top cover.

6 Remove the misfed paper.

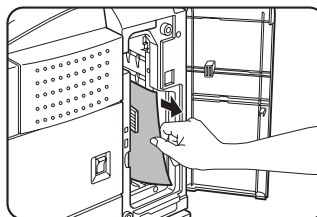

Be careful not to tear the misfed paper during removal.

2 Remove the misfed paper.

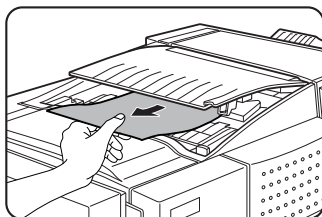

Be careful not to tear the misfed paper during removal. After removing the paper, press down on the top cover to close it.

7 Close the paper guide.

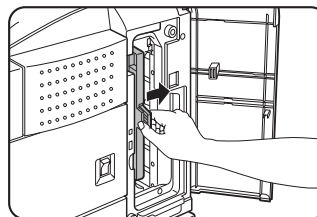

Close the paper guide securely.

3 If the misfed paper is not found in step 2, open the front cover.

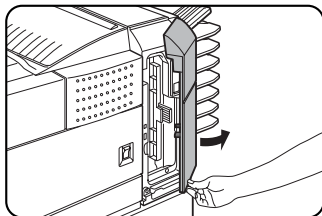

4 Turn the roller rotating knob in the direction of the arrow to remove the misfed paper.

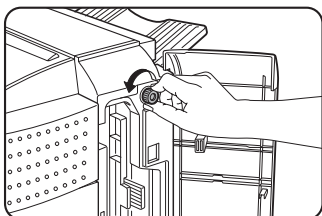

5 Open the paper guide.

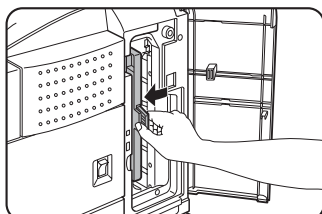

Unlatch the paper guide and open it in the direction of the arrow.

8 Close the front cover.

FINISHER

The finisher can deliver collated sets either stapled or unstapled. Unstapled sets can be offset stacked from the previous set for easy separation of the sets.

Part names

Latch

Release the latch to open the finisher for misfeed removal.

Top cover

Open for misfeed removal.

Staple box

Pull the box out to replace the staple cartridge or to remove jammed staples.

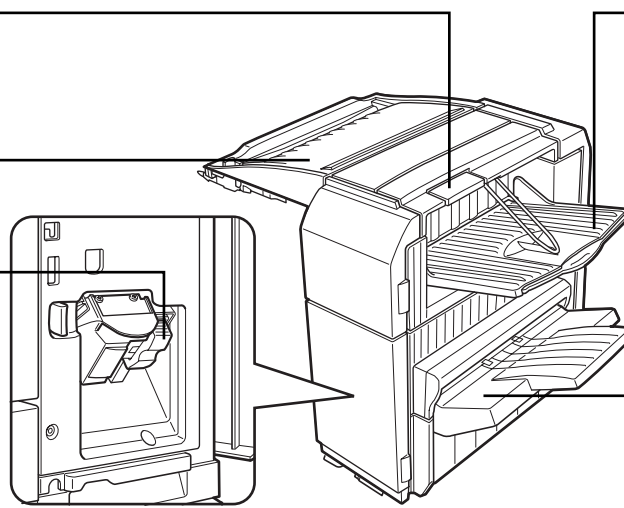

Top tray

Printer, copier and fax output can be delivered here.

To print onto large paper (A3, B4, 11" x 17", 8-1/2" x 14", or 8-1/2" x 13"), extend the tray.

Offset tray

Stapled sets or sets to be offset will be delivered here.

NOTES

- Do not put pressure on the finisher (particularly each tray).
- Do not place anything on the top cover. Doing so will interfere with the machine's paper handling during duplex printing.
- The tray moves up and down during operation. Be careful not to impede its movement.
- The finisher requires the installation of other peripheral devices in order to be functional and cannot be installed together with some other devices. The table on page 8-4 shows the configurations which are compatible.

Specifications

Name	Finisher (AR-FN6)
Number of trays	2
Paper output	Print face down
Tray type	Top tray: normal tray, Lower tray: offset tray
Tray capacity	Top tray: 500 sheets (A4 or 8-1/2" x 11" size, 80 g/m ² or 20 lbs.) Lower tray: 750 sheets (A4 or 8-1/2" x 11" size, 80 g/m ² or 20 lbs.)
Paper sizes	Top tray: same as the specifications of paper for feeding in the main unit Lower tray: Max. A4 or 8-1/2" x 11", Min. B5
Paper weight	Top tray: same as the specifications of paper for feeding in the main unit Lower tray: 60 to 128 g/m ² or 16 to 34 lbs.
Paper types	Top tray: same as the specifications of paper for feeding in the main unit Lower tray: plain paper only
Tray full detection	Provided in both the top tray and the lower tray
Offset function	Provided for the lower tray only. The offset amount is approx. 25 mm (1 inch)
Paper sizes for stapling	A4, B5, and 8-1/2" x 11"
Stapling capacity	30 sheets* (A4 or 8-1/2" x 11" or smaller 80 g/m ² or 20 lbs.) *Up two sheets of cover stock (128 g/m ² or 34 lbs.) can be included.
Staples	Single staple can be placed in the top left or lower left corners or two staples can be centred on the left side
Power supply	Supplied from machine
Dimensions	473 mm* (W) x 530 mm (D) x 508 mm (H) (18-5/8"* (W) x 20-7/8" (D) x 20" (H))
Weight	Approx. 21 kg (46.3 lbs.)

Specifications are subject to change for improvement without notice.

* When the top tray is extended.

Supplies

SC1 staple cartridges must be used for this finisher. The cartridge package contains three cartridges approx. 3000 staples each.

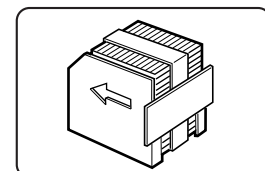

Finisher functions

Sort mode

Sorted sets will be delivered.

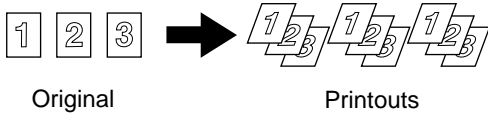

Group mode

Groups of prints or copies of the same page will be delivered.

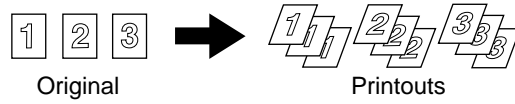

Offset mode

Offset mode

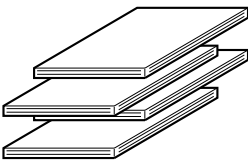

Non-offset mode

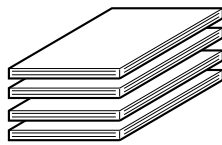

Sets will move from side to side so that each set or group will be offset from the previous set or group for easy separation. The offset function can only be used in the offset tray.

Stapled sets will not be offset.

Staple sort mode

Collated sets will be stapled and delivered to the offset tray. The stapling positions, orientation, paper size for stapling, and stapling capacity are shown below.

Stapling positions	Portrait orientation		Landscape orientation	
Top left corner of printouts		Available paper sizes: A4, B5, and 8-1/2" x 11" Stapling capacity: Up to 30 sheets for any available sizes	—	Stapling cannot be made.
Centre left two positions of printouts		Same as above		
Lower left corner of printouts		Same as above		

NOTES

- Stapling can only be done when the offset tray has been selected.
- If mixed paper sizes are selected for stapling jobs, stapling will be automatically cancelled.

NOTE

Transparency film heavy paper, punched paper, labels, envelopes and postcards cannot be stapled.

Using the finisher functions

When the [OUTPUT] key on the main screen of copy mode is touched, a screen for selecting the sort/group/staple sort functions and selecting an exit tray will appear. As a selection is made, the touch key for the selection will be highlighted.

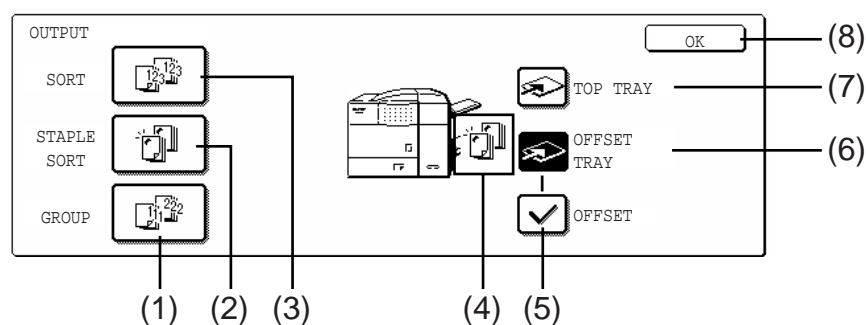

(1) [GROUP] key (See page 3-8.)

When Group is selected, all copies of the same original will be grouped.

(2) [STAPLE SORT] key (See page 3-8.)

When Staple Sort is selected, sorted sets will be stapled and delivered to the offset tray. (They will not be offset stacked.)

(3) [SORT] key (See page 3-8.)

When Sort is selected, sets of copies will be sequentially delivered.

(4) Icon display

An icon representing a selected function (sort, staple sort or group) is displayed.

(5) [OFFSET] key (See page 3-8.)

If Offset is checked, offset is enabled. If not checked, offset will not function. If staple sort is selected, the check mark of offset will be automatically cancelled. If the staple sort function is selected, the checkmark in the offset checkbox is automatically removed.

(6) [OFFSET TRAY] key (See page 3-8.)

When the offset tray is selected, copies will be delivered to the offset tray. When staple sort is selected, the offset tray will be automatically selected.

(7) [TOP TRAY] key

When top tray is selected, copies will be delivered to the top tray.

(8) [OK] key

Press to close the output screen and to return to the main screen.

Staple cartridge replacement

When the staple cartridge becomes empty, the message "Add staples." will appear in the message display of the operation panel.

Follow the procedure below to replace the staple cartridge.

1 Open the front cover.

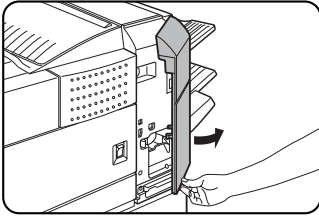

2 Turn the staple unit to face up.

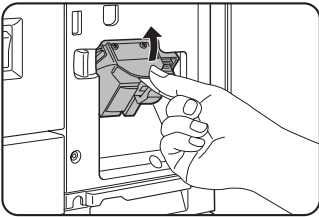

3 Pull the release lever for the staple box and remove the box.

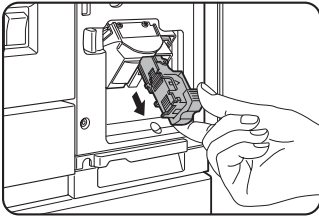

4 Remove the empty staple cartridge from the staple box.

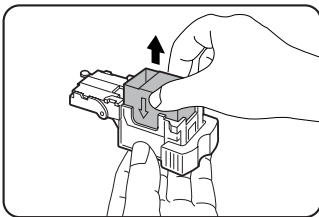

5 Insert a new staple cartridge into the staple box aligning the arrow of the staple cartridge with that of the staple box.

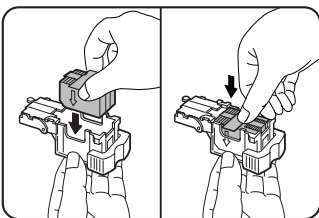

When reinstalling the staple box, push it in until it clicks into place.

NOTES

- Do not remove the tape from the cartridge before inserting the staple cartridge into the box.
- When reinstalling the staple box, push it in until it clicks into place.

6 Remove the tape from the staple cartridge by pulling it straight.

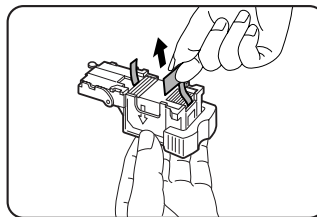

7 Reinstall the staple box.

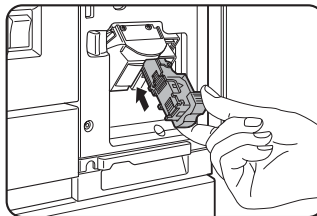

Push the staple box in until it clicks into place.

8 While pushing the staple unit release lever to the left, rotate the staple unit to face down.

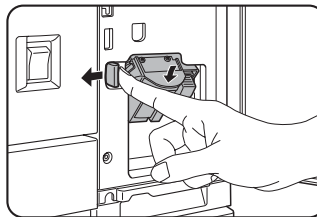

9 Close the front cover.

NOTE

Make a test print or copy in the staple sort mode to ensure that stapling is performed properly.

■ Checking the staple unit

If the message "CHECK THE STAPLER UNIT" or "CHECK STAPLER POSITION OR STAPLER JAM" appears, follow the procedure below.

1 Open the finisher compiler.

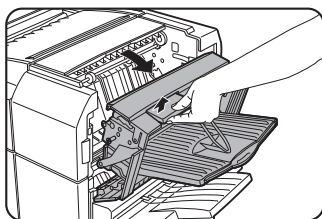

Release the latch to open the finisher compiler.

2 Remove the misfed paper from the stapler compiler.

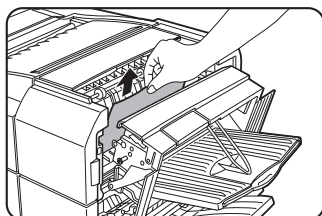

Be careful not to tear the misfed paper during removal.

3 Close the finisher compiler.

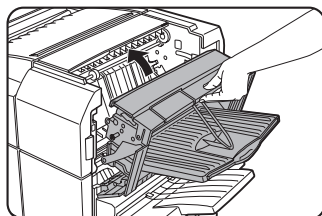

4 Open the finisher front cover.

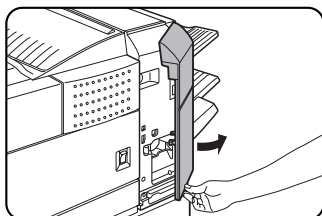

5 Turn the staple unit to face up.

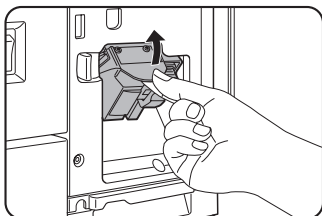

6 Pull the release lever for the staple box and remove the box.

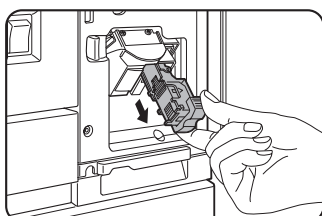

7 Raise the lever at the end of the staple box.

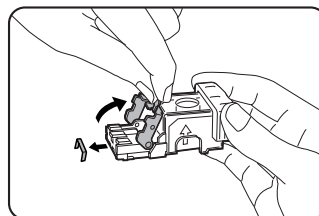

Remove the top staple if it is bent. If bent staples remain, a staple jam will occur again.

8 Return the lever to its original position.

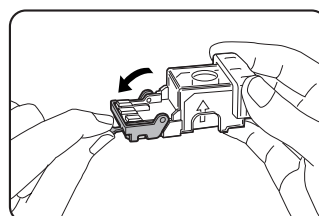

9 Reinstall the staple box.

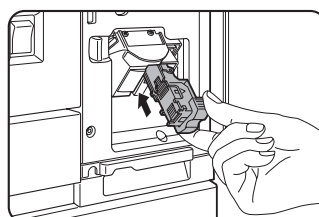

Push the staple box in until it clicks into place.

10 While pushing the staple unit release lever to the left, rotate the staple unit to face down.

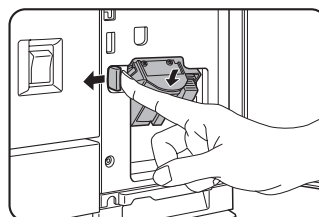

When reinstalling the staple box, push it in until it clicks into place.

11 Close the front cover.

NOTE

Make a test print or copy in the staple sort mode to ensure that stapling is performed properly.

3

Misfeed in the finisher

When a misfeed occurs in the finisher, remove the misfed paper following the procedure below.

1 Remove the misfed paper from the output area.

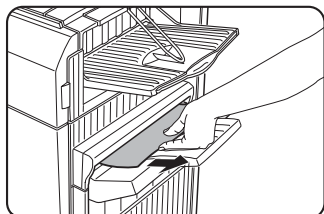

Be careful not to tear the misfed paper during removal.

5 Raise the paper guide and remove the misfed paper.

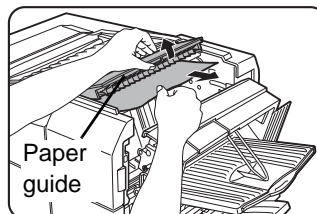

Be careful not to tear the misfed paper during removal.

2 Open the finisher top cover.

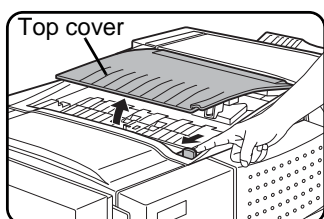

Move the tab in the direction of the arrow as shown in the illustration to open the top cover.

6 Close the finisher compiler.

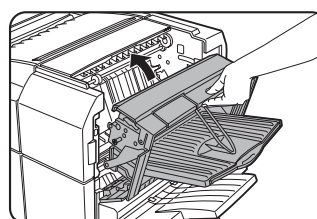

3 Remove the misfed paper.

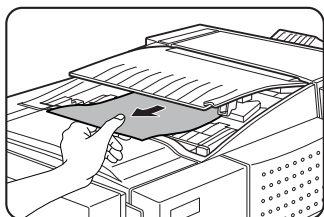

Be careful not to tear the misfed paper during removal.
After removing the paper, press down on the top cover to close it.

4 Open the finisher compiler.

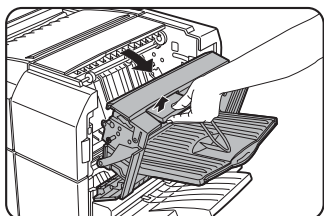

Release the latch to open the finisher compiler.

Troubleshooting finisher problems

Check the list below before calling for service.

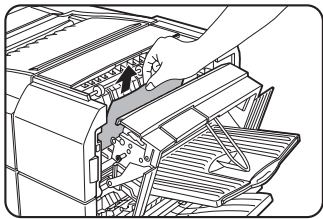
Problem	Check	Solution or cause
The finisher does not operate.	Are any finisher covers open?	Close all covers.
	Message indicating need to remove paper from the stapler compiler displayed?	Open the finisher as described in step 4 on page 3-12 and remove all paper from the stapler compiler. 
Stapling cannot be performed.	Is a "CHECK THE STAPLER UNIT" or "CHECK STAPLER POSITION OR STAPLER JAM" message displayed?	Check the staple unit. (See page 3-11.)
	Is a message "ADD STAPLES" displayed?	Replace the staple cartridge. (See page 3-10.)
	Different size paper included?	Stapling cannot be performed onto different size paper.
Stapled sets are not stacked correctly or some sheets in a set are not stapled.	Paper heavily curled?	Paper may be curled heavily depending on the paper type and quality. Remove paper from the paper tray or the bypass tray, turn it upside down, and load it again.

SADDLE STITCH FINISHER

The saddle stitch finisher can automatically place two staples for centreline binding of prints or copies and fold them along the centreline.

An optional hole punching unit is available for installation into the finisher.

Part names

Stapler compiler

Paper to be stapled is stacked temporarily.

Offset tray

Output which is stapled or offset will be delivered to this tray.

Saddle stitch tray

Saddle stitched output is delivered here.

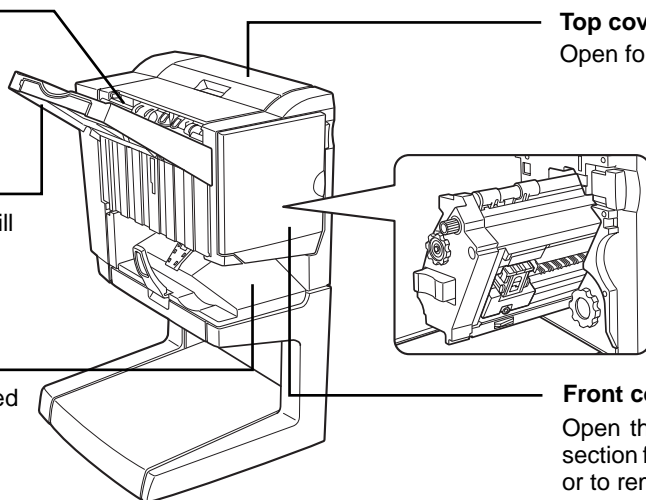

Top cover

Open for misfeed removal.

Stapler section

Open the front cover and pull out this section to replace the staple cartridge or to remove jammed staples.

Front cover

Open the front cover and pull out this section for staple cartridge replacement or to remove jammed staples.

NOTES

- Do not press on the saddle stitch finisher (particularly the offset tray).
- Be careful about the offset tray during printing because the tray moves up and down.
- The saddle stitch finisher requires the installation of other peripheral devices in order to be functional and cannot be installed together with some other devices. The table on page 8-4 shows the configurations which are compatible.

Specifications

Name	Saddle stitch finisher (AR-FN7)
Number of trays	2
Paper output	Print face down
Tray system	Upper tray: offset tray, Lower tray: saddle stitch tray
Tray capacity	Upper tray: Non-stapling: Max. 1,000 sheets for A4 or 8-1/2" x 11" or smaller sizes (80 g/m ² or 20 lbs.), max. 500 sheets for B4 or 8-1/2" x 13" or larger sizes (80 g/m ² or 20 lbs.) Stapling: Max. 50 stapled sets and max. 1,000 sheets for A4 or 8-1/2" x 11" or smaller sizes (80 g/m ² or 20 lbs.), max. 30 stapled sets and max. 500 sheets for B4 or 8-1/2" x 13" or larger sizes (80 g/m ² or 20 lbs.) Lower tray: Stapled print capacity is (6 - 10) sheets x 10 sets or (1 - 5) sheets x 20 sets.
Paper size	Upper tray: A3, B4, A4, A4R, B5, B5R, A5R, 11" x 17", 8-1/2" x 14", 8-1/2" x 13", 8-1/2" x 11", 8-1/2" x 11"R, 7-1/4" x 10-1/2", 5-1/2" x 8-1/2"R Lower tray: max. A3, B4, A4R, 11" x 17", 8-1/2" x 11"R
Paper weight	Upper tray: 60 to 205 g/m ² or 16 to 54 lbs. Lower tray: 64 to 80 g/m ² or 17 to 34 lbs.
Paper types	Upper tray: plain paper, thick paper, transparency film Lower tray: plain paper only
Tray full detection	Provided in both trays
Offset function	Upper tray only
Paper sizes for stapling	Upper tray: A3, B4, A4, A4R, B5, B5R, 11" x 17", 8-1/2" x 14", 8-1/2" x 13", 8-1/2" x 11", and 8-1/2" x 11"R, Lower tray: A3, B4, A4R, 11" x 17", and 8-1/2" x 11"R

(Continued on next page)

Stapling capacity	A4 or 8-1/2" x 11" or smaller size: 50 sheets*(80 g/m ² or 20 lbs.) B4 or 8-1/2" x 14" or larger size: 25 sheets*(80 g/m ² or 20 lbs.) *Up to two sheets of 128 g/m ² or 34 lbs. paper can be included as covers.
Staples	Upper tray: Single staple can be placed in the top left or lower left corners or two staples can be centred on the left side. Lower tray: 120 mm (4-47/64") pitch from the centre of paper
Power supply	Supplied from machine
Dimensions	753 mm* (W) x 603 mm (D) x 953 mm (H) (29-41/64"* (W) x 23-3/4" (D) x 37-33/64" (H)) *When the top tray is extended.
Weight	Approx. 39 kg (86 lbs.)

Name	Punch module			
Model*1	AR-PN1A	AR-PN1B*2	AR-PN1C*3	AR-PN1D*3
Number of holes	2	3 or 2	4	4
Paper sizes for hole punching	A3, B4, A4, A4R, B5, B5R, 11"x17", 8-1/2"x14", 8-1/2"x11", 8-1/2"x11"R	3 holes: A3, A4, 11" x 17", 8-1/2" x 11", 2 holes: 8-1/2"x14", 8-1/2" x 11"R	A3, A4	A3, B4, A4, A4R, B5, B5R, 11"x17", 8-1/2"x14", 8-1/2"x11", 8-1/2"x11"R,

3

- *1 Multiple punch modules cannot be installed together. Some models may not be available in some regions.
- *2 With PN1B, two or three holes can be punched depending on the paper size.
- *3 With PN1C and PN1D, the number of holes is the same. The hole interval, however, is not the same.

Specifications are subject to change for improvement without notice.

Supplies

SC2 staple cartridges must be used for this finisher. The cartridge package contains three cartridges approx. 5000 staples each.

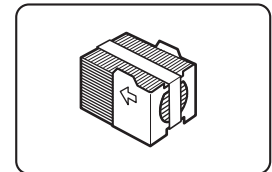

Saddle stitch finisher functions

Sort mode

Sorted sets will be delivered.

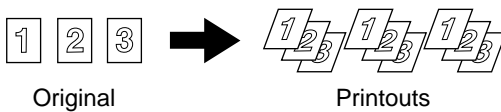

Group mode

Groups of copies of the same page will be delivered.

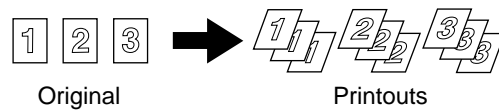

Offset mode

Offset mode

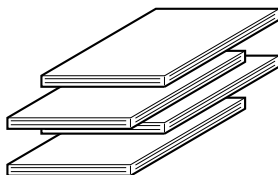

Non-offset mode

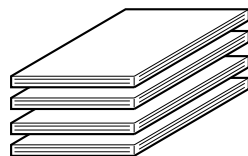





Sets will move from side to side so that each set or group will be offset from the previous set or group for easy separation. The offset function can only be used in the offset tray.

Stapled sets will not be offset.

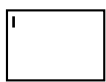
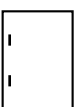
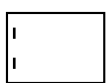
■ **Staple sort mode**

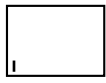
Collated sets of prints or copies will be stapled and delivered to the offset tray. When saddle stitching is selected, the prints or copies will be stapled at the centre and delivered to the saddle stitch tray. The stapling positions, orientation, paper size for stapling, and stapling capacity are shown below.

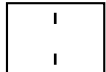
Stapling positions	Portrait orientation		Landscape orientation	
Top left corner of printouts		Available paper sizes: A4, B5, and 8-1/2" x 11" Stapling capacity: Up to 50 sheets for any sizes		Available paper sizes: A3, B4, A4R, 11" x 17", 8-1/2" x 14", 8-1/2" x 13", and 8-1/2" x 11" R Stapling capacity: Up to 50 sheets for A4R, B5R, and 8-1/2" x 11"R, and up to 25 sheets for other sizes
Centre left two positions of printouts		Same as above		Available paper sizes: A3, B4, A4R, 11" x 17", 8-1/2" x 14", 8-1/2" x 13", and 8-1/2" x 11" R Stapling capacity: Up to 50 sheets for A4R, B5R, and 8-1/2" x 11"R, and up to 25 sheets for other sizes
Lower left corner of printouts		Same as above		Available paper sizes: A3, B4, A4R, 11" x 17", 8-1/2" x 14", 8-1/2" x 13", and 8-1/2" x 11" R Stapling capacity: Up to 50 sheets for A4R, B5R, and 8-1/2" x 11"R, and up to 25 sheets for other sizes
Saddle stitch on centrefold line.		Paper in the portrait direction cannot be saddle stitched.		Available paper sizes: A3, B4, A4R, 11" x 17", and 8-1/2" x 11"R Stapling capacity: Up to 10 sheets for any sizes

■ **Original orientation when using the staple sort or punch function**

When using the staple sort or punch function, the original must be placed in the following orientations to enable stapling or punching in the desired position on the paper.

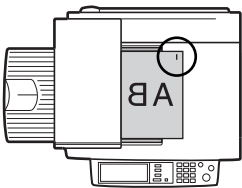
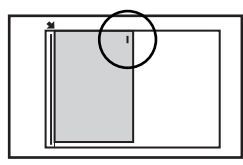
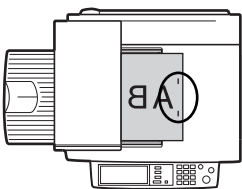
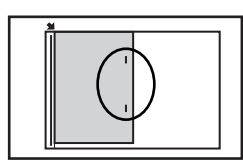
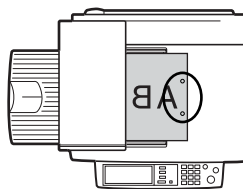
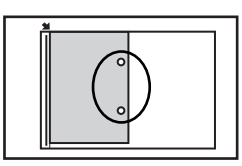
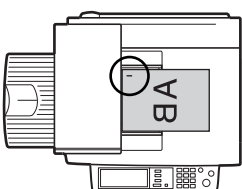
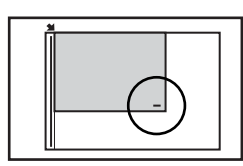
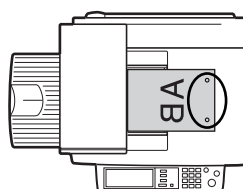
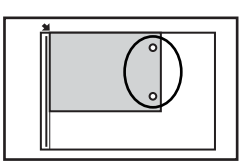
Staple sort		Punch	
Document feeder	Document glass	Document feeder	Document glass
			
			
			

■ **Saddle stitch function**

The saddle stitch finisher can automatically place two staples for centreline binding of prints or copies and fold them along the centreline.

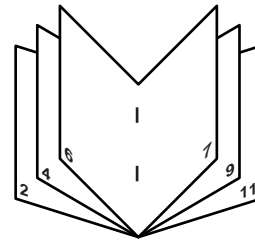

■ **Hole punching (only if a punch module is installed)**

If the saddle stitch finisher is equipped with a hole punch module, printed paper can be hole punched and delivered to the offset tray. Saddle stitching and hole punching cannot be selected at the same time. The automatic image rotation will not function when the hole punching function is used.

Two or three holes can be punched depending on the paper size. (See paper sizes for hole punching on page 4-4.)

If the punching function is enabled for a paper size that cannot be punched, the paper will be output without being punched. (For paper sizes that can be punched, see the specifications on page 3-15.) When using the punching function in copy mode, place the original with the top edge toward the back of the machine. If the original is not placed in this orientation, punching will not take place at the correct positions.

<Example>

{Original 1}

{Punch positions}

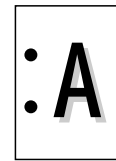
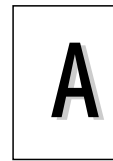

{Original 2}

{Punch positions}

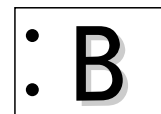

Using the saddle stitch finisher

When [OUTPUT] is selected on the main screen of copy mode, a screen for making selections for sort, group, staple sort, saddle stitch, punch and exit tray will appear.

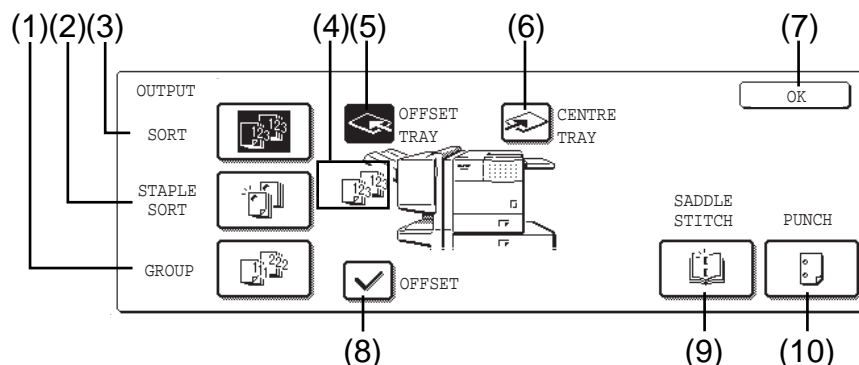

(1) [GROUP] key (See page 3-15.)

When Group is selected, all copies of the same original will be grouped.

(2) [STAPLE SORT] key (See page 3-16.)

When Staple Sort is selected, sorted sets will be stapled and delivered to the offset tray. (They will not be offset stacked.)

(3) [SORT] key (See page 3-15.)

When Sort is selected, sets of copies will be sequentially delivered.

(4) Icon display

An icon representing a selected function (sort, staple sort or group saddle stitch) is displayed.

(5) [OFFSET TRAY] key

If Offset is checked, the offset will be enabled. If not checked, the offset will not function. If the staple sort is selected, the check mark of offset will be automatically selected.

(6) [CENTRE TRAY] key

If the centre tray is selected, output paper will be delivered to the exit tray.

(7) [OK] key

Press to close the [OUTPUT] screen and to return to the main screen.

(8) [OFFSET] key (See page 3-15.)

When the offset tray is selected, copies will be delivered to the offset tray. When staple sort is selected, the offset tray will be automatically cancelled.

(9) [SADDLE STITCH] key (See page 3-17.)

When saddle stitching is selected, the copies will be stapled at the centre and delivered to the saddle stitch tray.

(10) [PUNCH] key (See page 3-17.)

If the saddle stitch finisher is equipped with a punch module, printed paper can be hole punched and delivered to the offset tray.

* As a selection is made, the touch key for the selection will be highlighted.

Staple cartridge replacement and staple jam removal

When the staple cartridge becomes empty or staples become jammed, a message will appear in the message display of the operation panel.

Follow the procedure below to replace the staple cartridge or remove jammed staples.

■ Staple cartridge replacement

1 Open the front cover.

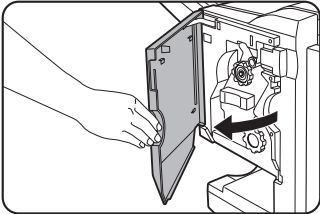

2 Pull out the stapler section.

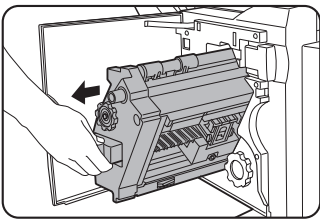

3 Turn roller rotating knob A in the direction of the arrow to move the staple unit to the front.

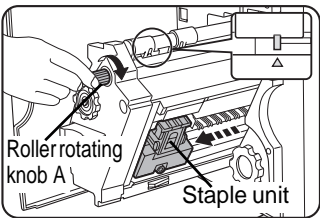

Turn the roller rotating knob until the triangle mark is aligned with the index.

4 Remove the empty staple box.

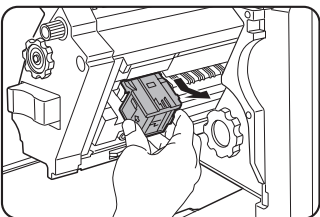

5 Remove the empty staple cartridge.

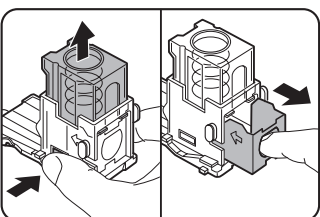

Press the lock button to unlock the staple box cover and remove the staple cartridge.

NOTE

If staples remain, the staple cartridge cannot be removed.

6 Insert a new staple cartridge into the staple box.

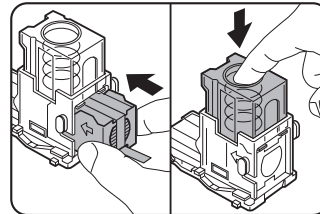

After inserting the staple cartridge, press down on the staple box cover to lock the cartridge in place.

NOTES

- Do not remove the tape from the cartridge before inserting the staple cartridge into the box.
- Make sure that the staple cartridge is secured firmly.
- When reinstalling the staple box, push it in until it clicks into place.

7 Remove the tape from the staple cartridge by pulling it straight.

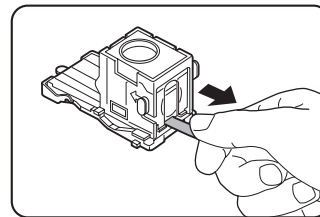

8 Insert the staple box.

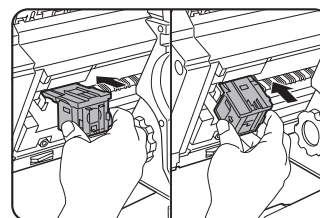

Push the staple box in until it clicks into place.

9 Push the stapler section back into the finisher.

10 Close the front cover.

NOTE

Make a test print or copy in the staple sort mode to ensure that stapling is performed properly.

■ Staple jam removal

1 Unlatch the saddle stitch finisher and slide it away from the machine.

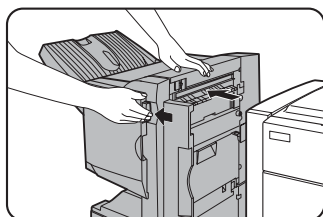

2 Open the front cover.

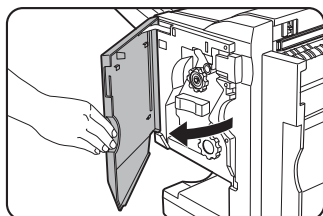

3 Turn roller rotating knob C as shown in the illustration until the blue indication is seen.

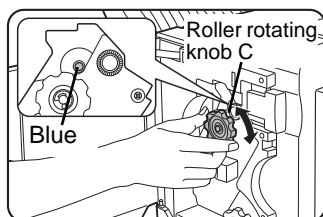

4 Remove the paper from the stapler compiler.

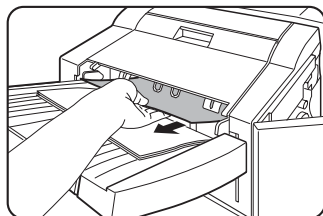

5 If saddle stitch was selected, open the saddle stitch section cover.

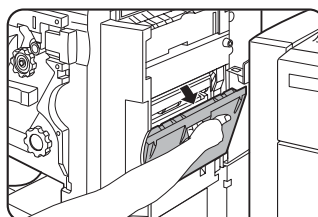

6 Remove the misfed paper.

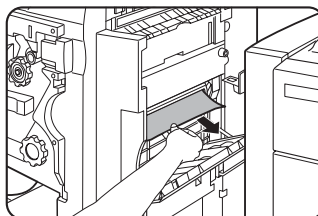

Be careful not to tear the misfed paper during removal.

7 Close the saddle stitch section cover.

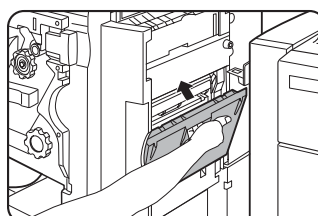

8 Open the front cover and pull out the stapler unit.

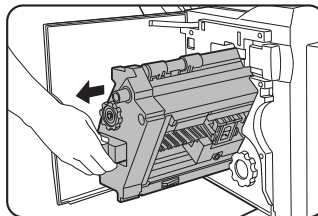

- 9** Turn roller rotating knob A in the direction of the arrow to move the staple unit to the front.

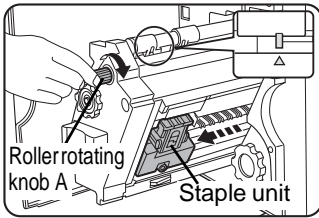

Turn the roller rotating knob until the triangle mark is aligned with the index.

- 10** Remove the staple box.

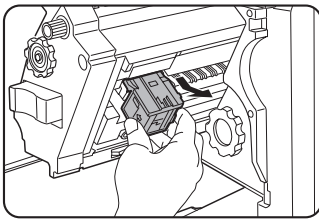

- 11** Raise the lever at the end of the staple box.

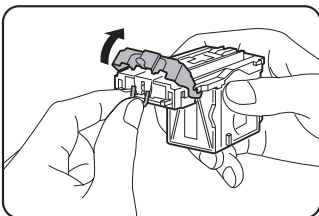

Remove the top staple if it is bent. If bent staples remain, a staple jam will occur again.

- 12** Return the lever to its original position.

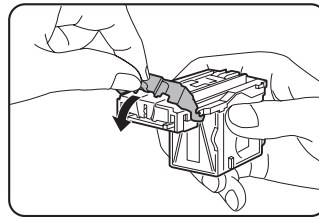

- 13** Reinstall the staple box.

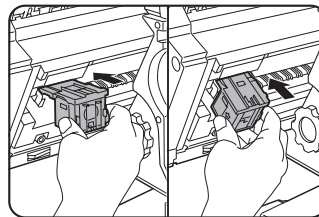

Push the staple box in until it clicks into place.

- 14** Push the stapler section back into the finisher.

- 15** Close the front cover.

- 16** Push the saddle stitch finisher back against the machine.

NOTE

Make a test print or copy in the staple sort mode to ensure that stapling is performed properly.

3

■ Disposal of hole punch scrap

- 1** Unlatch the saddle stitch finisher and slide it away from the machine.

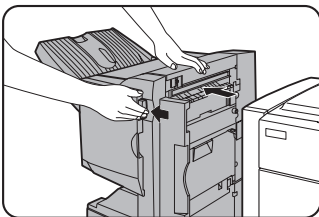

- 2** Pull out the punch scrap collecting container and empty it.

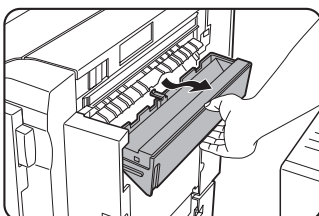

Empty the punch debris into a plastic bag or other container for disposal, taking care not to spill any of the punch debris.

- 3** Return the punch scrap collecting container to its original position.

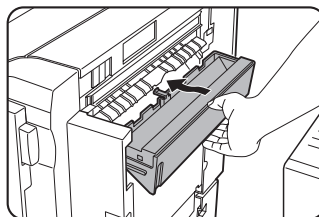

- 4** Push the saddle stitch finisher back against the machine.

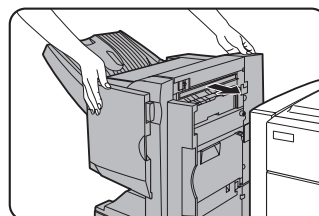

Misfeed in the saddle stitch finisher

When a misfeed occurs in the saddle stitch finisher, remove the misfed paper following the procedure below.

1 Press the detach button and separate the saddle stitch finisher from the machine.

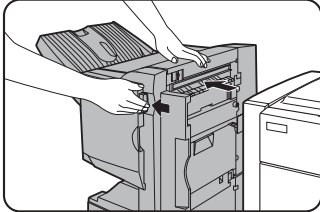

CAUTION
The saddle stitch finisher and the machine are connected at the rear. Exercise caution when pulling them apart.

2 Remove any misfed paper from the machine.

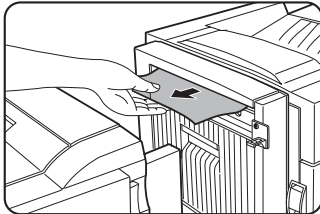

3 If there was no misfed paper in step 2, pull roller rotating knob B on the punch unit toward you and rotate it. (Only when an optional punch unit is installed.)

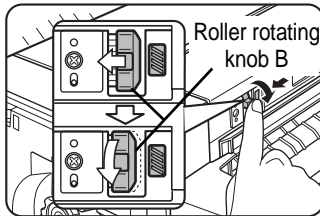

Rotating roller rotating knob B releases the caught paper.

4 Open the top cover.

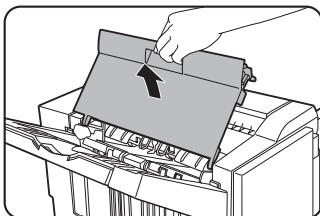

5 Remove the misfed paper.

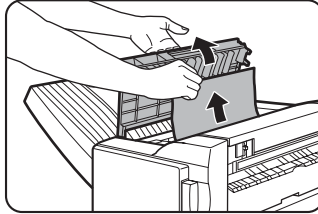

Remove the paper gently, taking care not to tear it.

6 Close the top cover.

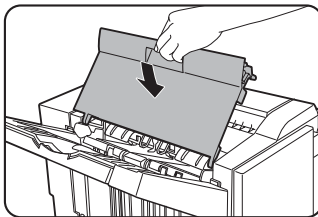

7 Remove any misfed paper from the stapler compiler.

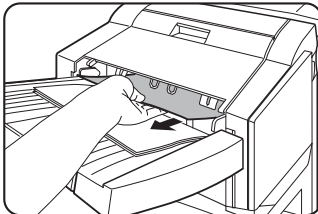

Remove the paper gently, taking care not to tear it.

8 Open the cover of the saddle stitch section.

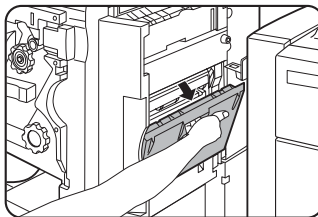

9 Remove the misfed paper.

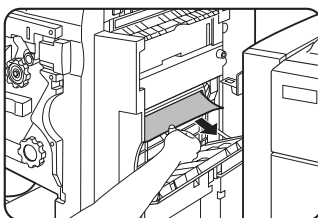

Remove the paper gently, taking care not to tear it.

10 Open the front cover.

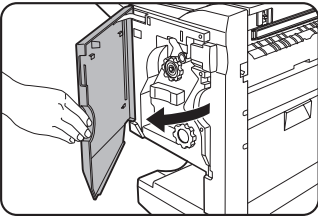

15 Push the saddle stitch finisher back onto the machine.

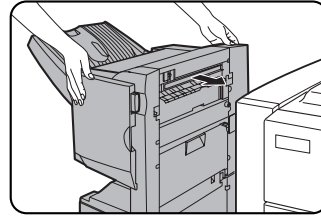

11 Rotate roller rotating knob D in the direction of the arrow.

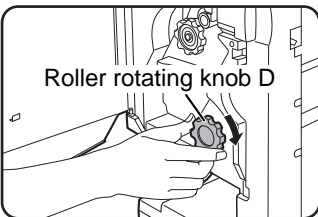

12 Remove any misfed paper from the saddle stitch tray.

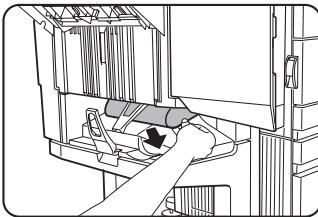

Remove the paper gently, taking care not to tear it.

13 Close the cover of the saddle stitch section.

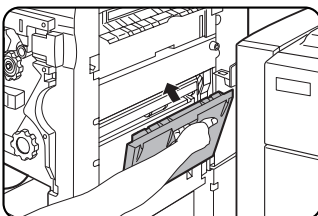

14 Close the front cover.

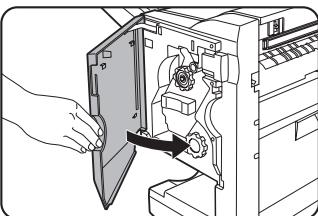

Troubleshooting (concerning the saddle stitch finisher)

Check the list below before calling for service.

Problem	Check	Solution or cause
The saddle stitch finisher does not operate.	Are any saddle stitch finisher covers open?	Close all covers. (See page 3-14.)
	Message indicating need to remove paper from the stapler compiler displayed?	Remove all remaining paper from the stapler compiler referring to step 4 on page 3-20.
Stapling cannot be performed (including saddle stitch).	Message requesting check for the staple unit displayed?	Remove jammed staples. (See page 3-20.)
	Message requesting adding staples displayed?	Replace the staple cartridge. (See page 3-19.) Check that a staple cartridge has been installed. (See page 3-20.)
	Different size paper included?	Stapling cannot be performed onto different size paper.
Stapled sets are not stacked correctly or some sheets in a set are not stapled.	Paper heavily curled?	Paper may be curled heavily depending on the paper type and quality. Remove paper from the paper tray or the bypass tray, turn it upside down, and load it again.
Punching does not take place in the correct positions.*	The punching function is not set for the correct positions.	Check the positions where punching is possible.
Cannot be punched.*	Message requesting check for punch module displayed?	Dispose of punch scraps. (See page 3-21.)
	Different size paper included?	Stapling cannot be performed onto different size paper.
	The paper is badly curled and is not punched.	Some types and qualities of paper may curl badly when printed on. Remove the paper from the tray or bypass tray, turn it around to reverse the top and bottom, and then place it back in the tray.

* When a punch module is installed

Part 2: Copier Operation



CHAPTER 4

MAKING COPIES

This chapter explains the basic procedures for making copies, including selection of the copy ratio and other copy settings.

	Page
AUTOMATIC DOCUMENT FEEDER.....	4-2
• Acceptable originals	4-2
PLACING ORIGINALS.....	4-3
CHECKING THE SIZE OF A PLACED ORIGINAL.....	4-5
• Manually setting the scanning size	4-5
STORING, DELETING, AND USING ORIGINAL SIZES	4-6
• Storing or deleting an original size	4-6
NORMAL COPYING	4-7
• Making copies with the automatic document feeder	4-7
• Automatic two-sided copying using the automatic document feeder....	4-10
• Copying from the document glass.....	4-11
• Automatic two-sided copying from the document glass	4-13
ADJUSTING THE EXPOSURE	4-14
REDUCTION/ENLARGEMENT/ZOOM.....	4-15
• Automatic selection (auto image).....	4-15
• Manual selection (preset copy ratios/zoom).....	4-16
• XY ZOOM.....	4-18
SPECIAL PAPERS	4-20

AUTOMATIC DOCUMENT FEEDER

The automatic document feeder automatically feeds originals into the machine, making continuous copying possible. In addition, both sides of two-sided sheet originals can be simultaneously scanned. This function is convenient when you have a large number of original pages to scan.

Acceptable originals

A stack of up to 50 original sheets (30 original sheets*¹ for B4 (8-1/2" x 14") or larger) of the same size paper can be set in the document feeder tray provided the stack height is within the limit shown below.

A stack of up to 30 mixed size originals can be set if the width of the originals is the same and the stack height is within the limit shown below. In this case, however, stapling and duplex will not function and some special functions may not give the expected result.

*¹ For paper heavier than 105 g/m² (28 lbs.), only a stack of up to 15 sheets can be set. Setting 16 or more sheets may cause incorrect scanning of original and scanned image may become expanded compared with original itself.

■ Size and weight of acceptable originals

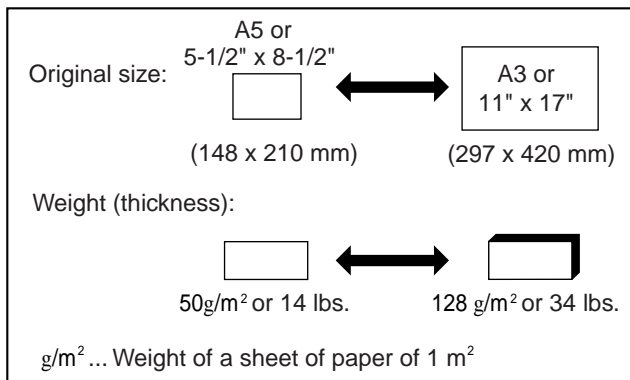

■ Total number of originals that can be set in the document feeder tray

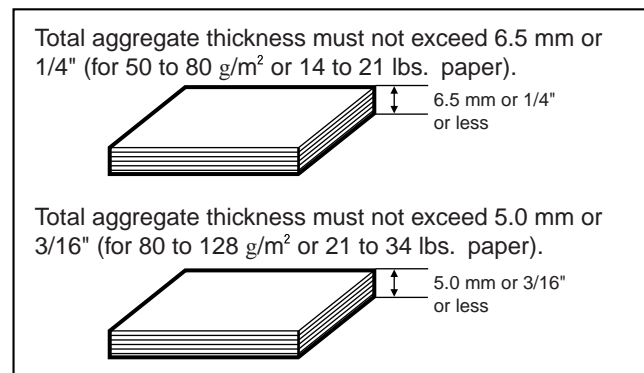

■ Notes on use of the automatic document feeder

- Use originals within the specified size and weight ranges. Use of originals out of the specified range may cause an original misfeed.
- Before loading originals into the document feeder tray, be sure to remove any staples or paper clips.
- If originals have damp spots from correction fluid, ink or glue from pasteups, be sure they are dried before they are fed. If not, the interior of the document feeder or the document glass may be soiled.
- Do not use the following originals. These originals may cause incorrect original size detection, original misfeeds, and smudges on copies.
 - Transparency film, tracing paper, carbon paper, thermal paper or originals printed with thermal transfer ink ribbon should not be fed through the document feeder. Originals to be fed through the feeder should not be damaged, crumpled or folded or have loosely pasted paper on them or cutouts in them. Originals with multiple punched holes other than two-hole or three-hole punched paper may not feed correctly.
- When using originals with two or three holes, place them so that the punched edge is at a position other than the feed slot.

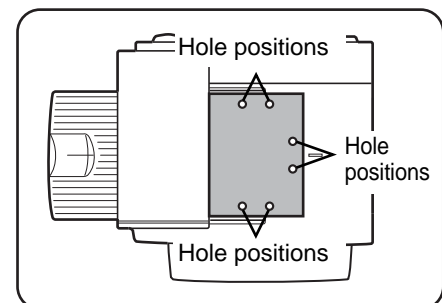

PLACING ORIGINALS

■ Using the automatic document feeder

1 Open the document cover, make sure that an original has not been left on the document glass, and then gently close the document cover.

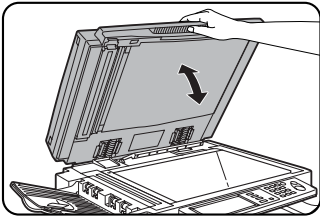

2 Adjust the original guides to the size of the originals.

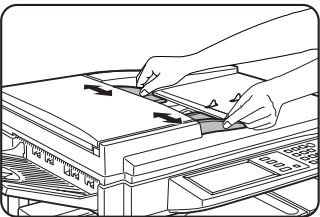

3 Place the originals face down in the document feeder tray.

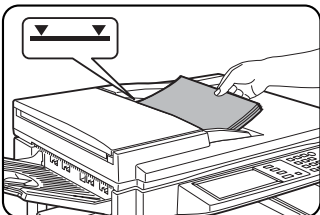

Place the originals face down.

Insert the originals all the way into the document feeder. The stack height must not be higher than the indicator

line (maximum of 50 pages).

■ Using the document glass

Open the document cover, place the original face down on the document glass, and then gently close the document cover.

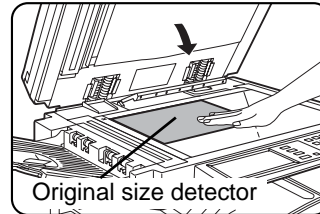



To make a copy of a small original such as a postcard, use the [PAPER SELECT] key to select the desired paper size.

NOTE

Do not place any objects under the original size detector, because they may damage it or the original size may not be detected properly.

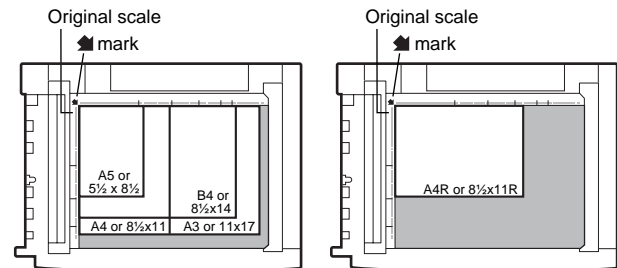
4



- Align the corner of the original with the tip of the arrow mark  on the document glass scale.
- Place the original in the appropriate position for its size as shown above.

NOTE

Original size detection function

One of the four groups of standard original sizes shown below can be selected for detection by the original size detection function. The factory default setting is "AB-1 (INCH-1)". The setting can be changed using "ORIGINAL SIZE DETECTOR SETTING" in the key operator programs.

	Group	Detectable original sizes	
		Document feeder tray (for automatic document feeder)	Document glass
1	INCH-1	11" x 17", 8-1/2" x 14", 8-1/2" x 11", 8-1/2" x 11"R, 5-1/2" x 8-1/2"	Document glass + A3, A4
2	INCH-2	11" x 17", 8-1/2" x 13", 8-1/2" x 11", 8-1/2" x 11"R, 5-1/2" x 8-1/2"	Document glass + A3, A4
3	AB-1	A3, A4, A4R, A5, B4, B5, B5R	Document glass + 11" x 17", 8-1/2" x 11", 216x330
4	AB-2	A3, A4, A4R, A5, B5, B5R, 216x330	Document glass + 11" x 17", 8-1/2" x 11", B4

■ Standard original placement orientations

[Example 1]

Document feeder tray

Document glass

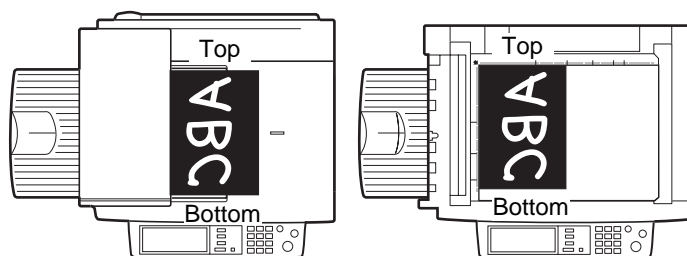

Place originals in the document feeder tray or on the document glass so that the top and bottom of the original is positioned as shown in the illustration. If not, staples will be incorrectly positioned and some special features may not give the expected result.

[Example 2]

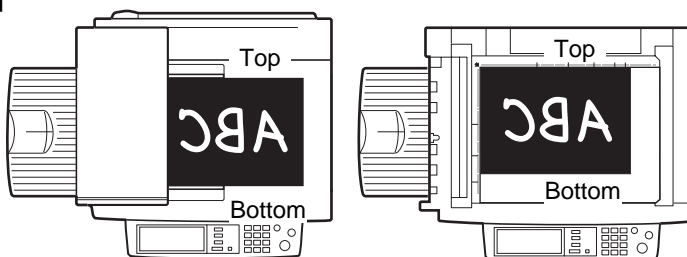

■ Automatic copy image rotation - rotation copying

If the orientation of the originals and copy paper are different, the original image will be automatically rotated 90° and copied. (When an image is rotated, a message will be displayed.) If a function is selected that is not suitable for rotation, such as enlarging the copy to greater than A4 (8-1/2" x 11") size or staple sorting with the saddle stitch finisher, rotation will not be possible.

[Example]

Orientation of original

Orientation of paper

Copy after rotation

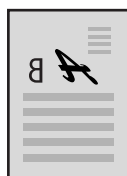

Face down



Face down

- This function operates in both the auto paper select or auto image mode. ("Rotation copy setting" can be disabled with a key operator program. See page 14 of the key operator's guide.)

CHECKING THE SIZE OF A PLACED ORIGINAL

If the placed original is a standard size, the size will be automatically detected (automatic original detection function) and displayed in the touch panel. Make sure that the correct size has been detected.

(A) : The original size is displayed.

(B) : [AUTO] appears when the automatic original detection function is operating.

If you have loaded a non-standard size original or wish to change the scanning size, you can follow the steps below to manually set the original scanning size. (For the standard sizes, see "Original size detection function" on page 4-3.)

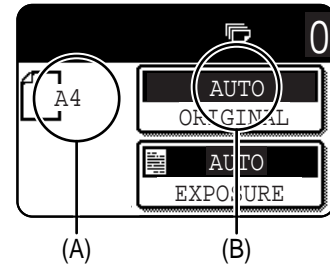

NOTE

If a non-standard size original is loaded (including special sizes), the closest standard size may be displayed, or the original size may not appear at all.

If "CANCEL DETECTION AT DOCUMENT GLASS" is enabled in the key operator programs (see page 11 of the key operator's guide), automatic original detection at the document glass will not operate. In this case, follow the steps below to manually set the original scanning size.

Manually setting the scanning size

If you load an original that is not a standard size (such as an AB size), or if the size is not detected correctly, you must touch the [ORIGINAL] key and set the original size manually. Perform the following steps after placing the document in the automatic document feeder or on the document glass.

1 Touch the [ORIGINAL] key.



2 Touch the desired original size key.

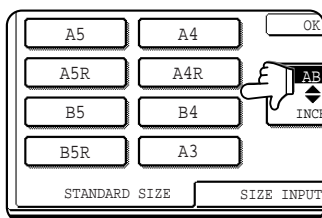

[AUTO] is no longer highlighted. [MANUAL] and the original size key you touched are highlighted.

If you wish to select an INCH size, touch the [AB/INCH] key and then touch the desired original size key.

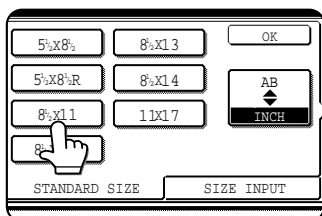

[INCH] is highlighted and INCH size keys are displayed. To return to the inch palette, touch the [AB/INCH] key once again.

If a non-standard size original is placed in the document feeder or on the document glass, touch the [SIZE INPUT] tab and then enter the X (width) and Y (length) dimensions of the original.

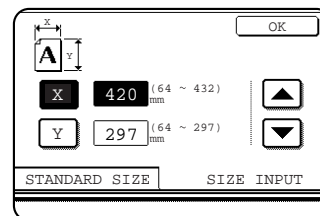

X is initially selected. Enter the X dimension (width) and then touch the Y key and enter the Y dimension (length). X can be from 64 to 432 mm, and Y can be from 64 to 297 mm.

If you frequently use originals that are the same non-standard size, you can store the size as explained in "STORING, DELETING, AND USING ORIGINAL SIZES" on the following page. This will save you the trouble of manually entering the size each time you use that original size.

3 Touch the [OK] key.

You will return to the initial screen.

4 The selected original size appears in the top half of the [ORIGINAL] key.



STORING, DELETING, AND USING ORIGINAL SIZES

Up to 9 special original sizes can be stored. Stored sizes can be easily called up and are not erased if the power is turned off. Storing a frequently used original size saves you the trouble of manually setting the size each time you copy that size of document.

- To cancel an original size storing, using, or deleting operation, press the [CA] key or touch the [ORIGINAL] key on the screen.

Storing or deleting an original size

- 1 Touch the [ORIGINAL] key.

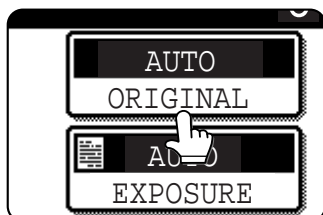

- 2 Touch the [CUSTOM SIZE] key.

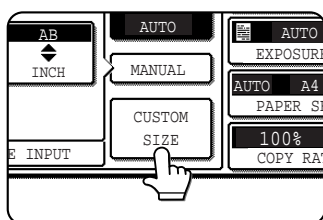

- 3 Touch the [STORE/DELETE] key.

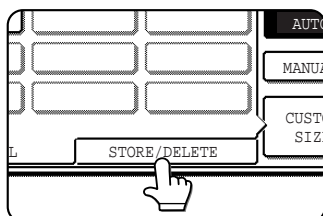

- 4 Touch the original size key () that you wish to store or delete.

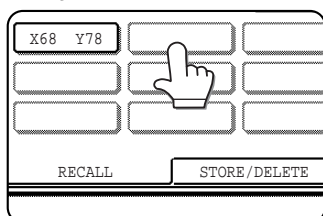

To store an original size, touch a key that does not show a size ().

Keys that already have an original size stored will show the stored size (X68 Y78).

To delete or change a stored size, touch the key that shows the size that you wish to delete or change.

- If you are storing an original size, go to step 5.
- To delete or change an original size, go to step 7.

- 5 Enter the X (width) and Y (length) dimensions of the original with the \uparrow \downarrow keys.

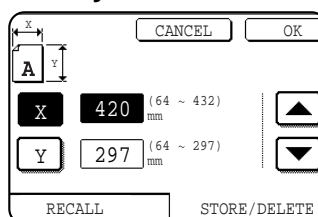

X (width) is initially selected.

Enter X and then touch the (Y) key to enter Y. A width of 64 to 432 mm can be entered in X, and a length of 64 to 297 mm

can be entered in Y.

- 6 Touch the [OK] key.

The original size entered in step 5 is stored in the key selected in step 4.

To exit, touch the [ORIGINAL] key.

- 7 When you touch a key that shows an original size in step 4, a message screen appears that contains the keys [CANCEL], [DELETE], and [AMEND].

- To cancel the procedure, touch the [CANCEL] key.
- To delete the selected original size, touch the [DELETE] key.
- To change the original size stored in the key, touch the [AMEND] key. The screen of step 5 will appear to let you change the size.

- 8 To exit, touch the [ORIGINAL] key.

■ USING A STORED ORIGINAL SIZE

- 1 Follow steps 1 to 2 of "STORING OR DELETING AN ORIGINAL SIZE".

- 2 Touch the original size key that you wish to use.

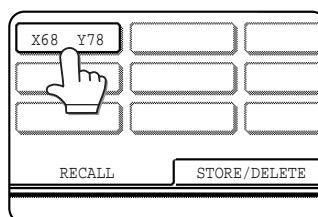

- 3 Touch the [OK] key.

The stored original size is called up.

NORMAL COPYING

This section describes the normal copying procedure.

Making copies with the automatic document feeder

■ 1-sided copies of 1-sided originals

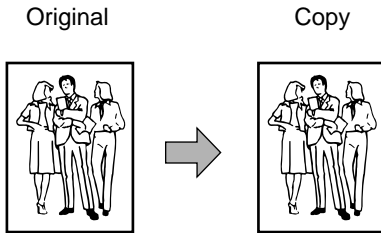

- 1 Place the originals in the document feeder tray. (pages 4-3 to 4-6)

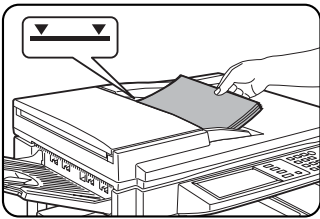

- 2 Make sure that the 1-sided to 1-sided copy mode is selected.

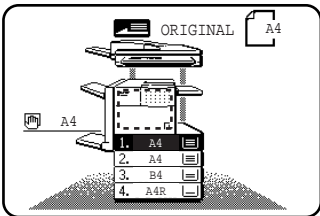

The one-sided to one-sided mode is selected when no icon for a two-sided mode appears in the dashed area on the display. If the 1-sided to 1-sided copy mode is already selected, steps 3 to 5 are not needed.

- 3 Touch the [2-SIDED COPY] key.

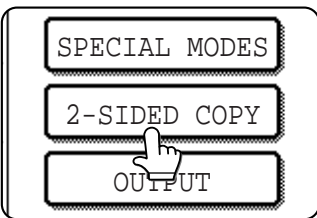

- 4 Touch the [1-sided to 1-sided copy] key.

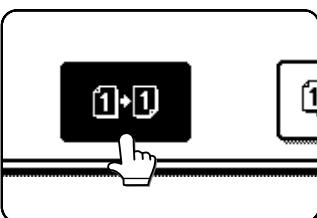

Touch the [1-sided to 1-sided copy] key.

- 5 Touch the [OK] key.

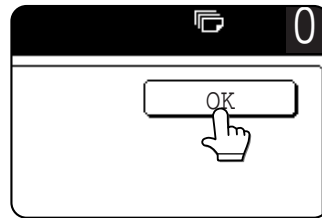

- 6 Make sure that paper of the same size as the originals is automatically selected*.

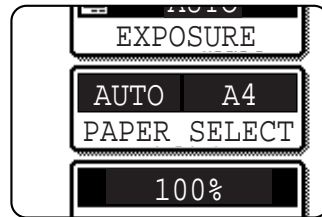

The selected tray will be highlighted or the message "LOAD xxxxxx PAPER." will appear. If the message appears, load paper in a paper tray with paper of the required size.

Even if the message above appears, copying can be performed onto the currently selected paper.

*The following requirements must be satisfied.

Originals of a standard size (A3, B4, A4, A4R, B5, B5R or A5 (11" x 17", 8-1/2" x 14", 8-1/2" x 11", 8-1/2" x 11"R or 5-1/2" x 8-1/2R")) are set and the auto paper select function is enabled.

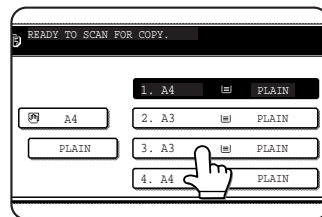

If originals of a size other than the sizes above are to be copied, manually select the desired paper size by touching the [PAPER SELECT] key and then touching the desired paper size selection key.

The selected key will be highlighted and the paper selection screen will close.

To close the paper selection screen without making a selection, touch the [PAPER SELECT] key.

7 Select the desired output mode (page 4-9).

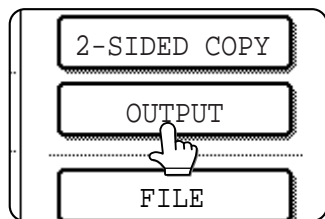

The sort mode is the default mode. To select the group mode, touch the [OUTPUT] key, then touch the [GROUP] key on the output setting

screen, and then touch the [OK] key on the setting screen.

8 Use the numeric keys to set the desired number of copies.

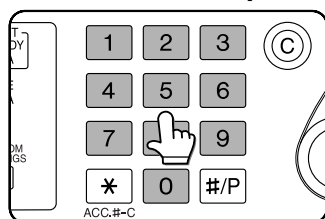

Up to 999 can be set. If you are only making a single copy, the copy can be made with the copy number display showing "0". Use the [C] (clear) key to cancel an entry if

a mistake has been made.

9 If needed, touch the [FILE] key or the [QUICK FILE] key*.

* Can only be used on the d-Copia 3501 / 4501, or when the document filling function has been added.

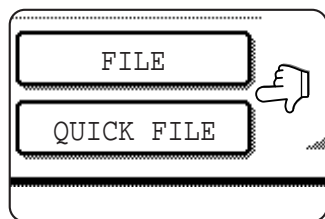

Either key can be touched to store the scanned document image on the machine's hard disk. The stored image can be re-used later.

For more information on this function, see "Document filing function" in chapter 7.

If the [FILE] key is greyed out, only the [QUICK FILE] key can be selected.

When you touch the [QUICK FILE] key, a message asking you to confirm the save will appear. Touch the [OK] key in the message screen and go to the next step.

If you wish to cancel the save, touch the [QUICK FILE] key after touching the [OK] key so that the [QUICK FILE] key is no longer highlighted.

10 Press the [START] key.

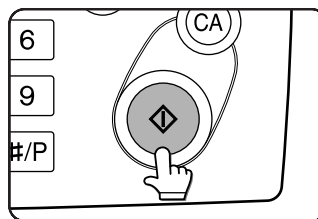

If the [C] key is pressed while originals are being scanned, scanning will stop. If copying had already started, copying and scanning will stop after the original in

progress is output to the original exit area. In these cases the copy quantity will be reset to "0".

NOTES

- The 1-sided to 1-sided copying mode is set as the default in the initial settings. If the default setting has not been changed using the "Initial status settings" program (key operator program), steps 3 to 5 on page 4-7 can be omitted.

To cancel copying...

To cancel a copy job in progress, press the [CA] key. A confirmation message will appear. Touch the [YES] key to cancel copying.

■ Copy output (sort and group)

Example: Making five sets or five copies each of three originals

● Sorting copies into sets

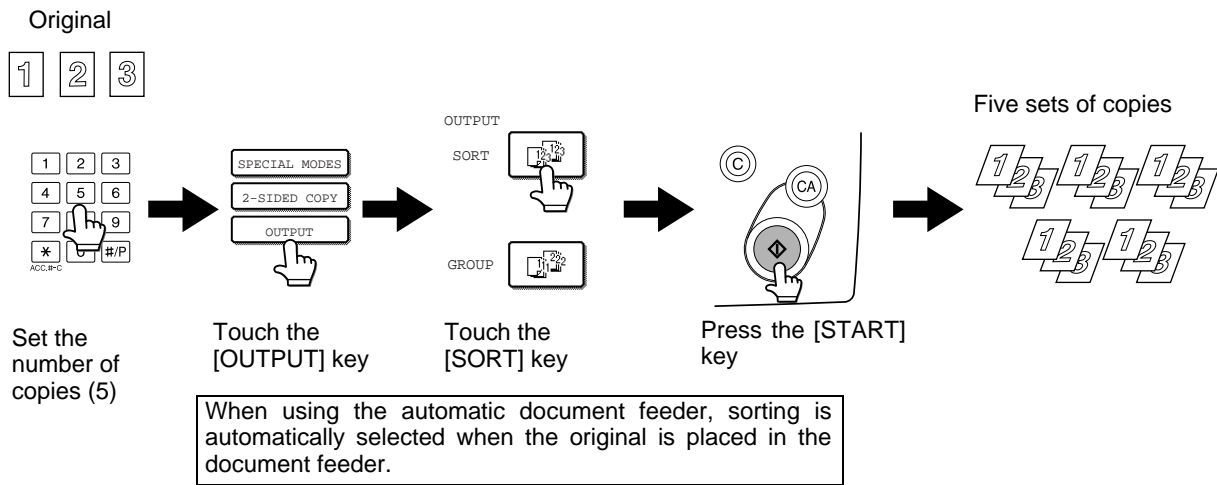

● Grouping copies by page

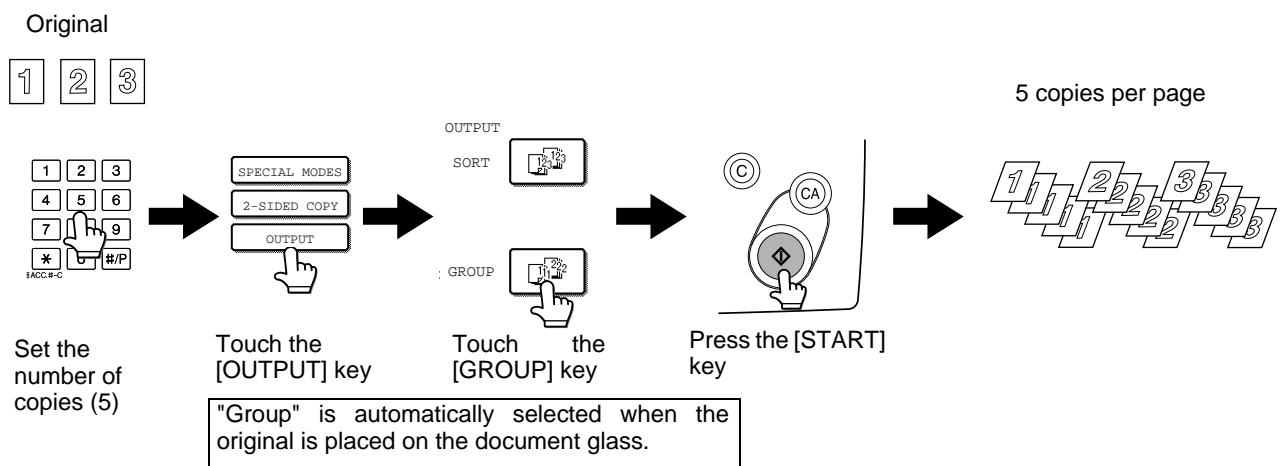

4

■ Selecting the output tray (when an optional finisher or saddle stitch finisher is installed)

When the [OFFSET TRAY] key is highlighted, output pages are delivered to the offset tray of the finisher or saddle stitch finisher. When the "CENTRE TRAY" key is highlighted, output pages are delivered to the centre tray. Touch the appropriate key to select the desired output tray.

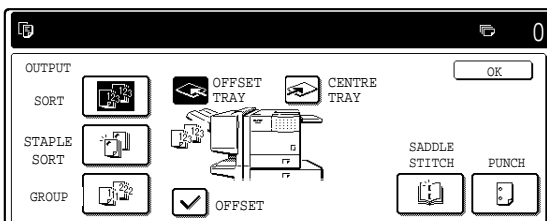

This screen appears when a saddle stitch finisher is installed. The screen that appears when a finisher is installed is slightly different.

Automatic two-sided copying using the automatic document feeder

When the optional duplex module is installed, the following automatic two-sided copying can be performed. The paper is automatically turned over during copying, allowing two-sided copies to be made with ease.

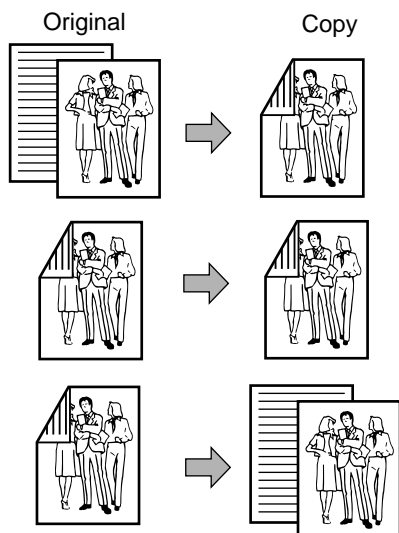

1. Automatic two-sided copying from one-sided originals
2. Automatic two-sided copying from two-sided originals
3. Automatic one-sided copying from two-sided originals

1 Place the originals in the document feeder tray. (pages 4-3 to 4-6)

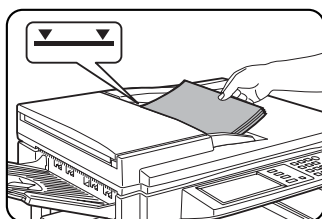

2 Touch the [2-SIDED COPY] key.

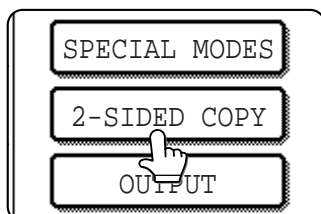

3 Select the desired copy mode.

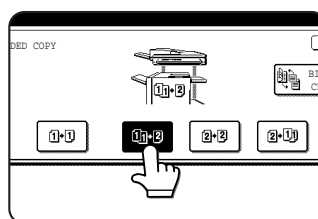

The display will vary depending on the equipment installed.

If a copy key is touched for a mode that cannot be selected, a double beep will sound.

Example of a portrait-oriented original

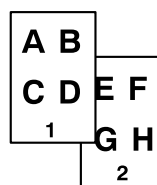

Example of a landscape-oriented original

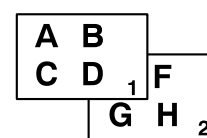

When making automatic two-sided copies of a one-sided A3 (11" x 17") or B4 (8-1/2" x 14") size portrait original, or when you wish to invert the top and bottom of the back side of a two-sided original, touch the [BINDING CHANGE] key.

4 Touch the [OK] key.

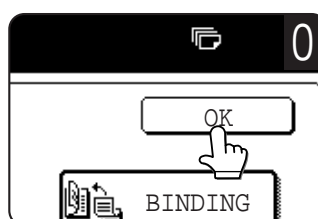

Perform steps 6 through 10 on pages 4-7 and 4-8.

Copying from the document glass

When copying originals which cannot be fed from the automatic document feeder such as thick originals, open the document cover and copy the originals from the document glass.

■ 1-sided copies of 1-sided originals

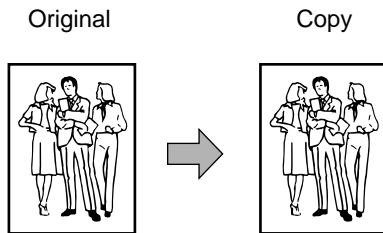

1 Place the original on the document glass. (pages 4-3 to 4-6)

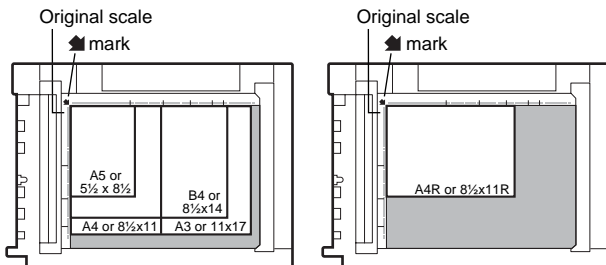
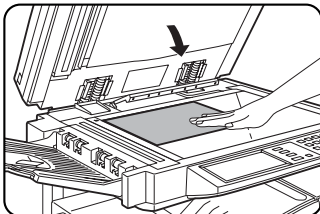

- Align the corner of the original with the tip of the arrow mark on the document glass scale.
- Place the original in the appropriate position for its size as shown above.

2 Ensure that the 1-sided to 1-sided copy mode is selected.

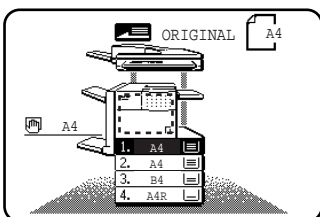

The one-sided to one-sided mode is selected when no icon for a two-sided mode appears in the dashed area on the display. If an icon appears, perform steps 3 to 5 on page 4-7 and then go to step 3.

3 Ensure that paper of the same size as the original is automatically selected*.

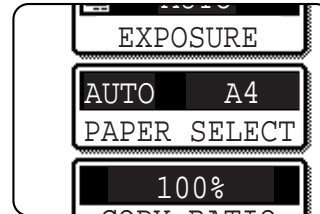

The selected tray will be highlighted or the message "LOAD xxxxxx PAPER." will appear. If the message appears, load paper in a paper tray with paper of the

required size.

Even if the message above is displayed, copying can be performed onto the currently selected paper.

* The following requirements must be satisfied.

Originals of a standard size (A3, B4, A4, A4R, B5, B5R or A5 (11" x 17", 8-1/2" x 14", 8-1/2" x 11", 8-1/2" x 11"R or 5-1/2" x 8-1/2"R)) are set and the auto paper select function is enabled.

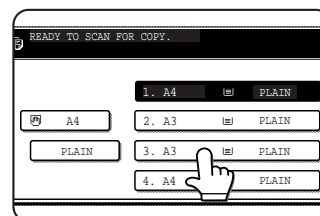

If originals of a size other than the sizes above are to be copied, manually select the desired paper size by touching the [PAPER SELECT] key and then touching the

desired paper size selection key.

The selected key will be highlighted and the paper selection screen will close. To close the paper selection screen without making a selection, touch the [PAPER SELECT] key.

4 Select the desired output mode. (page 4-9.)

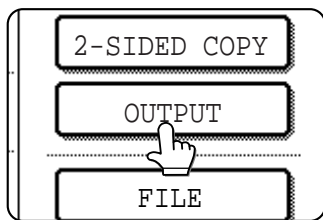

Group mode is the default mode.

To select sort mode, touch the [OUTPUT] key, touch the [SORT] key in the screen that appears, and then touch the [OK] key.

5 Use the numeric keys to set the desired number of copies.

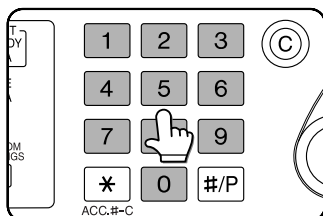

Up to 999 can be set. If you are only making a single copy, the copy can be made with the copy number display showing "0".

Use the [C] (clear) key to cancel an entry if a mistake has been made.

6 If needed, touch the [FILE] key or the [QUICK FILE] key*.

* Can only be used on the d-Copia 3501 / 4501 version, or when the document filling function has been added.

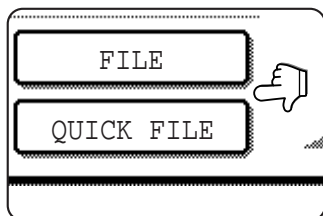

Either key can be touched to store the scanned document image on the machine's hard disk. The stored image can be re-used later.

For more information on this function, see "Document filing function" in chapter 7.

If the [FILE] key is greyed out, only the [QUICK FILE] key can be selected.

When you touch the [QUICK FILE] key, a message asking you to confirm the save will appear. Touch the [OK] key in the message screen and go to the next step.

If you wish to cancel the save, touch the [QUICK FILE] key after touching the [OK] key so that the [QUICK FILE] key is no longer highlighted.

7 Press the [START] key.

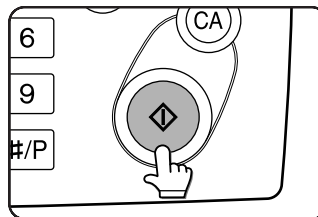

Replace the original with the next original and press the [START] key. Repeat this operation until all originals have been scanned.

If you selected "Sort" for the output mode in step 4 and pressed the [START] key, it is necessary to touch the [READ-END] key.

8 Touch the [READ-END] key.

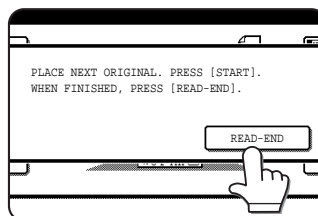

To cancel copying...

To cancel a copy job in progress, press the [CA] key. A confirmation message will appear. Touch the [YES] key to cancel copying.

Automatic two-sided copying from the document glass

When the optional duplex module is installed, the following automatic two-sided copying can be performed. The paper is automatically turned over during copying, allowing two-sided copies to be made with ease.

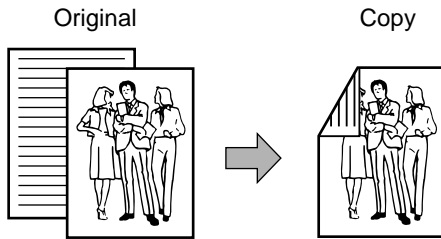

1 Place the original on the document glass. (pages 4-3 to 4-6)

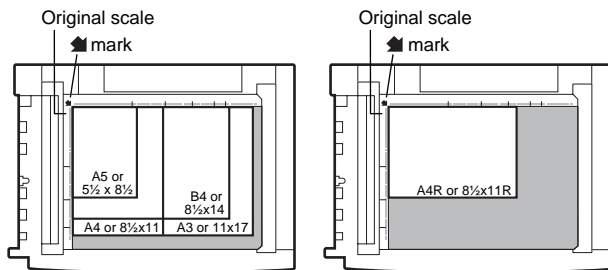
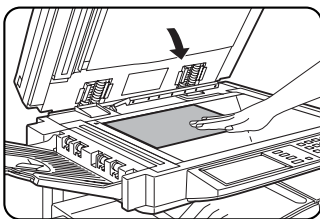

- Align the corner of the original with the tip of the arrow mark  on the document glass scale.
- Place the original in the appropriate position for its size as shown above.

2 Touch the [2-SIDED COPY] key.

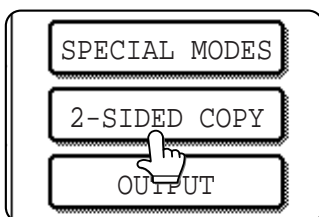

3 Touch the [1-sided to 2-sided copy] key.

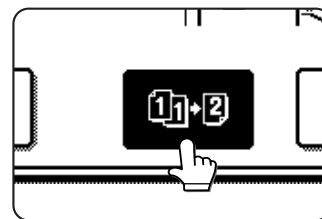

Example of a portrait-oriented original

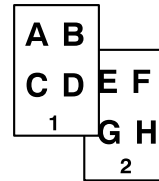

Example of a landscape-oriented original

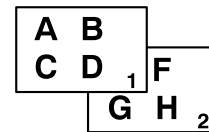

When making automatic two-sided copies of a one-sided A3 (11" x 17") or B4 (8-1/2" x 14") size portrait original, or when you wish to invert the top and bottom of the back side of a two-sided original, touch the [BINDING CHANGE] key.

4 Touch the [OK] key.



Perform steps 3 to 8 on pages 4-11 and 4-12.

4

ADJUSTING THE EXPOSURE

Select an appropriate exposure mode for the original to be copied. The selections are AUTO, TEXT, TEXT/PHOTO and PHOTO.

Automatic exposure adjustment

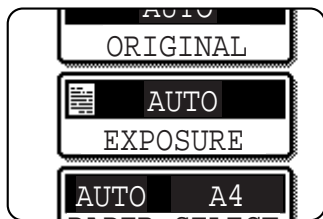

The default exposure setting is "AUTO", which automatically adjusts the exposure for the original. To select the exposure mode, or to manually adjust the exposure level, follow the steps below.

Selecting the exposure mode and manually adjusting the exposure level

1 Touch the [EXPOSURE] key.

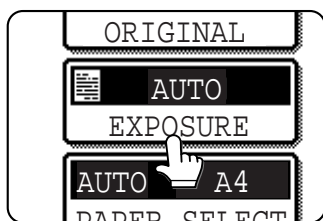

3 Adjust the exposure level.

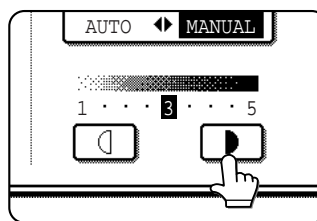

Touch the key to make darker copies. Touch the key to make lighter copies.

2 Select [TEXT], [TEXT/PHOTO] or [PHOTO] as appropriate for the original to be copied.

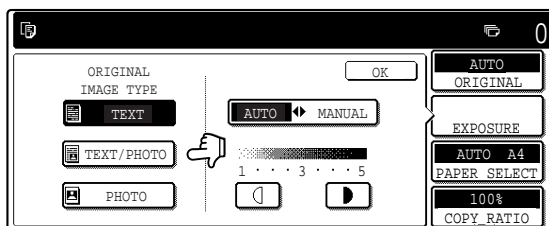

To select [TEXT], touch the [AUTO ◀▶ MANUAL] key so that [MANUAL] is selected.

Exposure modes selection

- TEXT:** This mode is useful for producing dark text copies with minimum background.
- TEXT/PHOTO:** This provides the best balance for copying an original which contains both text and photos. This mode is also useful for copying printed photographs.
- PHOTO:** This mode provides the best copies of photographs with fine details.

NOTE

Exposure levels in TEXT mode

- 1 to 2: Dark originals such as newspaper
- 3: Normal density originals
- 4 to 5: Originals written with pencils or light colour characters

About the steps that follow

If an automatic document feeder is being used, see pages 4-7 through 4-10. If the document glass is being used, see pages 4-11 through 4-13.

NOTES

- To return to the automatic exposure mode, touch the [AUTO / MANUAL] key to highlight [AUTO], and then touch the [OK] key.
- The exposure level used in automatic exposure mode can be adjusted in the key operator programs. See "Exposure adjustment" on page 14 of the key operator's guide)

REDUCTION/ENLARGEMENT/ZOOM

Reduction and enlargement ratios can be selected automatically or manually.

- Automatic selection: Auto image (see below)
- Manual selection: Preset copy ratios/zoom (see page 4-16)

Automatic selection (auto image)

The reduction or enlargement ratio will be selected automatically based on the original size and the selected paper size.

1 Place the original in the document feeder tray or on the document glass. (pages 4-3 to 4-6)

The detected original size will be displayed.

NOTE

Automatic ratio adjustment can only be used for the following original and paper sizes. It cannot be used for other sizes. However, in the case of non-standard original and paper sizes, the sizes can be entered to make automatic ratio adjustment possible for those sizes.

Original sizes: Standard sizes (see "Original size detection function" on page 4-3.)

Paper size: A3, B4, A4, A4R, B5, B5R, or A5R (11" x 17", 8-1/2" x 14", 8-1/2" x 11", 8-1/2" x 11"R, or 5-1/2" x 8-1/2"R)

2 Touch the [PAPER SELECT] key and then select the desired paper size.

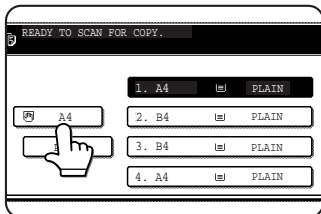

The selected paper size key is highlighted and the paper selection screen closes.

NOTE

If paper of the desired size is not loaded in any tray, load paper of the required size in a paper tray. (See "Setting the paper type and paper size" on page 2-5.)

3 Touch the [AUTO IMAGE] key.

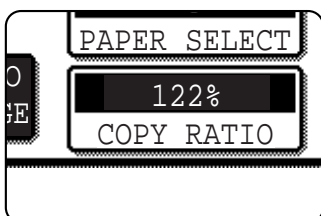
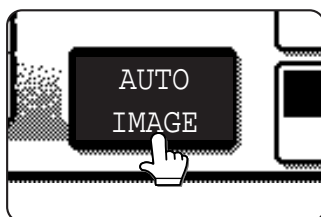

The [AUTO IMAGE] key will be highlighted and the best reduction or enlargement ratio for the original size and the selected paper size will be selected and

displayed in the copy ratio display.

NOTE

If the message "ROTATE ORIGINAL FROM [Landscape icon] TO [Portrait icon]" is displayed, change the orientation of the original as indicated in the message. When the message above is displayed, copying can be done without changing the orientation, but the image will not fit the paper correctly.

4 Use the numeric keys to set the desired number of copies.

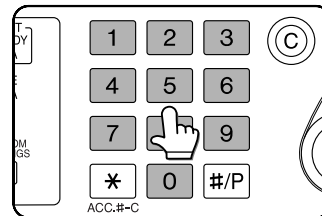

Up to 999 can be set. If you are only making a single copy, the copy can be made with the copy number display showing "0".

Use the [C] (clear) key to cancel an entry if a mistake has been made.

5 If needed, touch the [FILE] key or the [QUICK FILE] key*.

* Can only be used on the d-Copia 315 Network version, or when the document filling function has been added.

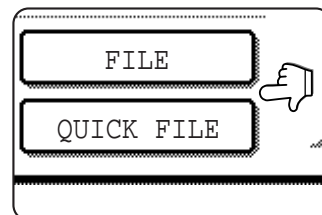

Either key can be touched to store the scanned document image on the machine's hard disk. The stored image can be re-used later.

For more information on this function, see "Document filing function" in chapter 7.

If the [FILE] key is greyed out, only the [QUICK FILE] key can be selected. When you touch the [QUICK FILE] key, a message asking you to confirm the save will appear. Touch the [OK] key in the message screen and go to the next step.

If you wish to cancel the save, touch the [QUICK FILE] key after touching the [OK] key so that the [QUICK FILE] key is no longer highlighted.

6 Press the [START] key.

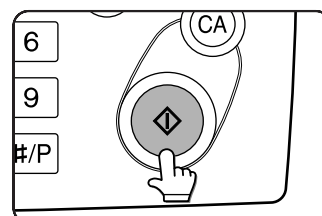

If you placed the original on the document glass, set the output mode to "Sort", and pressed the [START] key, you must touch the [READ-END] key after all pages of the

original have been scanned. (Step 8 on page 4-12)

To cancel the auto image mode, touch the [CA] key.

4

Manual selection (preset copy ratios/zoom)

Preset ratios (maximum 400%, minimum 25%) can be selected with the enlargement and reduction keys. In addition, the zoom keys can be used to select any ratio from 25% to 400% in increments of 1%.

<The key operator program on page 14 of the key operator's guide can be used to set two additional enlargement ratios and two additional reduction ratios.>

- 1 Place the original in the document feeder tray or on the document glass. (pages 4-3 to 4-6)

NOTE

When the original is placed in the document feeder, the ratio can be set from 25% to 200%.

- 2 Touch the [COPY RATIO] key.

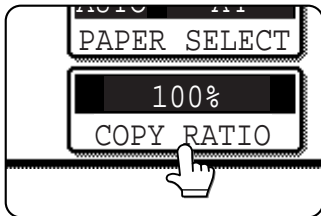

- 3 Use the [MENU] key to select menu "1" or menu "2" for copy ratio selection.

Menu 1

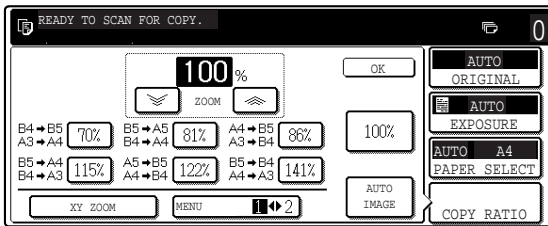

- A. Preset reduction copy ratios are:
70%, 81% and 86% (for the AB system).
77% and 64% (for the inch system).
- B. Preset enlargement copy ratios are:
115%, 122% and 141% (for the AB system).
121% and 129% (for the inch system).

Menu 2

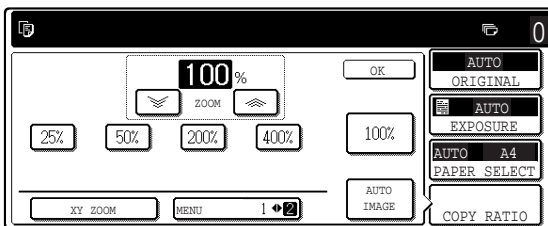

- A. Preset reduction copy ratios are:
50% and 25%.
- B. Preset enlargement copy ratios are:
200% and 400%.

(The custom ratios set by the key operator appear in ratio menu 2.)

- 4 Use the reduction, enlargement, and [ZOOM] keys on the touch panel to set the desired copy ratio.

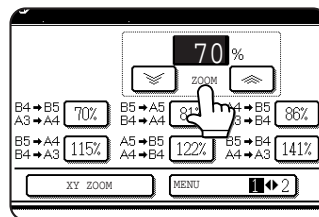
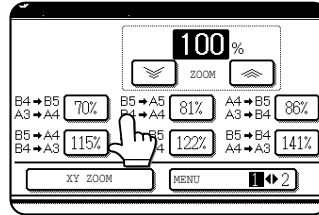

Zoom ratios: Any ratio from 25% to 400% can be set in 1% increments. Touch the [ZOOM] key to increase the ratio, or the [ZOOM] key to decrease the ratio. (If you continue to touch the [ZOOM]/[ZOOM] key, the ratio will change automatically. After 3 seconds, the ratio will change rapidly.)

NOTES

- Touch a reduction or enlargement key to set the approximate ratio, then touch the [ZOOM] key to increase the ratio or the [ZOOM] key to decrease the ratio.
- Automatic changing of the ratio when a zoom key is continuously touched can be disabled in the key operator programs (see "Key operation setting (prohibit key repeat)" on page 10 of the key operator's guide).
- If the message "IMAGE IS LARGER THAN COPY PAPER." appears when a ratio is selected, the image may not fit on the copy paper.
- To set the horizontal and vertical copy ratios separately, use the XY ZOOM feature. See page 4-18.

- 5 Touch the [OK] key.

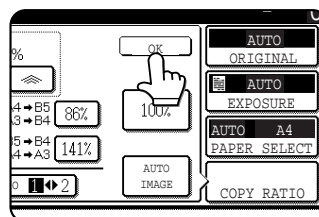

6 Make sure that an appropriate paper size has been selected based on the selected ratio.

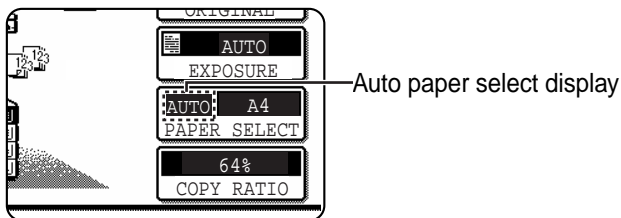

NOTE

If the auto paper select display does not appear, a tray with the correct size of paper for the selected ratio will not be automatically selected.

7 Use the numeric keys to set the desired number of copies.

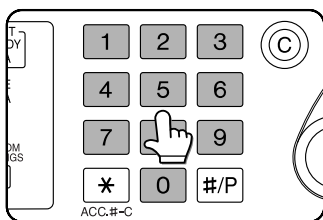

Up to 999 can be set. If you are only making a single copy, the copy can be made with the copy number display showing "0".

Use the [C] (clear) key to cancel an entry if a mistake has been made.

8 If needed, touch the [FILE] key or the [QUICK FILE] key*.

* Can only be used on the d-Copia 315 Network version, or when the document filling function has been added.

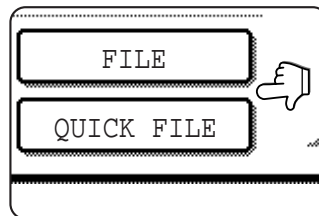

Either key can be touched to store the scanned document image on the machine's hard disk. The stored image can be re-used later.

For more information on this function, see "Document filing function" in chapter 7.

If the [FILE] key is greyed out, only the [QUICK FILE] key can be selected.

When you touch the [QUICK FILE] key, a message asking you to confirm the save will appear. Touch the [OK] key in the message screen and go to the next step.

If you wish to cancel the save, touch the [QUICK FILE] key after touching the [OK] key so that the [QUICK FILE] key is no longer highlighted.

9 Press the [START] key.

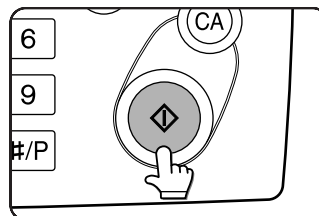

If you placed the original on the document glass, set the output to "Sort", and pressed the [START] key, you must touch the [READ-END] key after all pages of the

original have been scanned. (Step 8 on page 4-12)

To return the ratio to 100%

To return the ratio setting to 100%, touch the [COPY RATIO] key to display the ratio menu and then touch the [100%] key. (Steps 2 and 3 on page 4-16.)

XY ZOOM

The XY ZOOM feature allows the horizontal and vertical copy ratios to be changed separately. The ratios can be set from 25% to 400% in increments of 1%.

Example: Selecting 100% for the length and 50% for the width

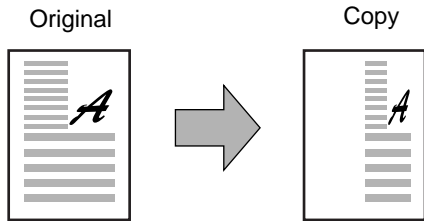

- 1 Place the original in the document feeder tray or on the document glass. (pages 4-3 to 4-6)

NOTE

When the original is placed in the document feeder, the ratio can be set from 25% to 200%.

- 2 Touch the [COPY RATIO] key.

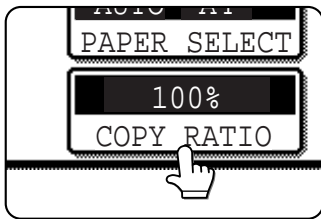

- 3 Touch the [XY ZOOM] key.

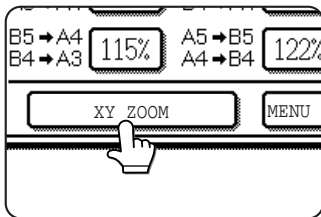

- 4 Touch the [X] key.

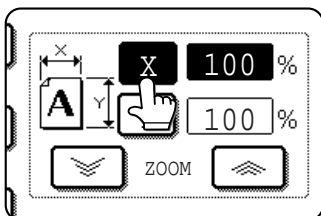

The initial state of the [X] key is selected (highlighted), so this step normally is not necessary. Touch the [X] key only if it is not highlighted yet.

- 5 Use the reduction, enlargement, and ZOOM ([], []) keys to change the copy ratio in the horizontal (X) direction.

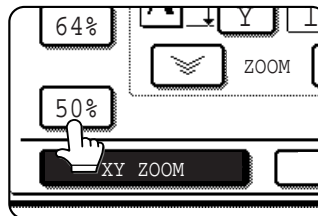

A fixed ratio key will not become highlighted when touched.

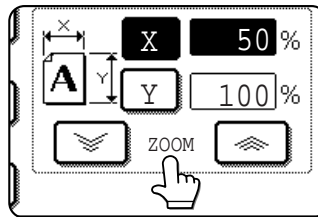

Zoom ratios: Any ratio from 25% to 400% can be set in 1% increments. Touch the [] key to increase the ratio, or the [] key to decrease the ratio. (If you continue



to touch the []/[] key, the ratio will change automatically. After 3 seconds, the ratio will change rapidly.)

NOTES

- Touch a reduction or enlargement key to set the approximate ratio, then touch the [] key to increase the ratio or the [] key to decrease the ratio.
- Automatic changing of the ratio when a zoom key is continuously touched can be disabled in the key operator programs (see "Key operation setting (prohibit key repeat)" on page 10 of the key operator's guide).

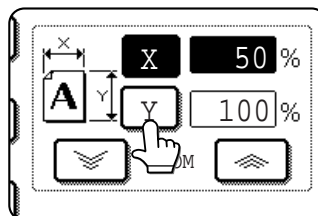
- 6 Touch the [Y] key.



7 Use the reduction, enlargement, and ZOOM ([, [) keys to change the copy ratio in the vertical (Y) direction.

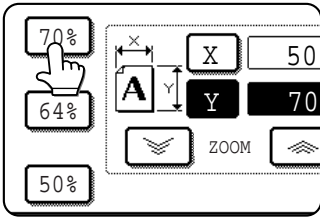

A fixed ratio key will not become highlighted when touched.

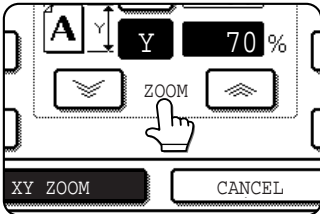

The zoom keys can be used to change the ratio from 25% to 400% in increments of 1%. If needed, you can touch the [X] key once again to readjust the X zoom.

8 Touch the [OK] key.

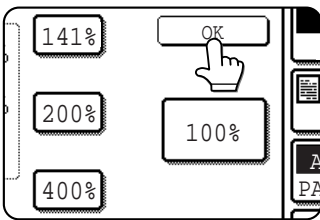

9 If needed, touch the [PAPER SELECT] key and select the paper size.

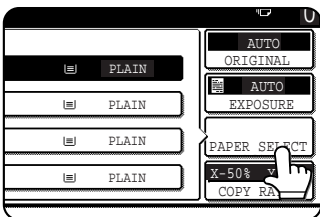

If the AUTO PAPER SELECT mode is on, the appropriate copy paper size will have been automatically selected based on the original size and selected copy ratios.

10 Select any desired copy settings such as the exposure or number of copies, and then press the [START] key.

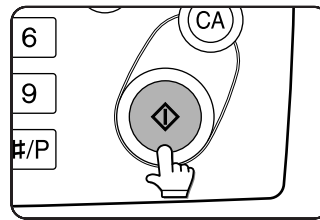

To cancel an X or Y zoom setting...
Touch the [XY ZOOM] key or the [CANCEL] key in the ratio selection screen (step 3 or 7 on page 4-18).

SPECIAL PAPERS

The tray 2 and the bypass tray on the optional duplex module with bypass tray can be used to make copies on transparencies, postcards, label sheets, envelopes*1, and plain paper.

*1 Envelopes can be placed in the tray 2.

- 1 Place the original in the document feeder tray or on the document glass. (pages 4-3 to 4-6)

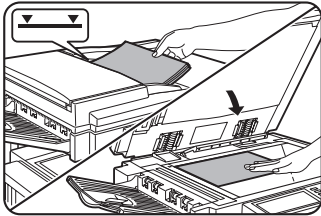

- 2 Load the special paper in the bypass tray.

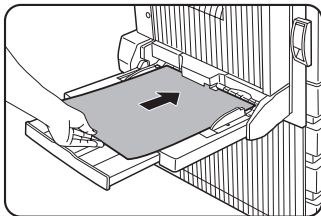

Place the paper with the printed side face down. See page 2-3 for the specifications of paper that can be used in the bypass tray. For the paper loading instructions, see "Loading paper in the bypass tray" (page 3-3).

- 3 Touch the [PAPER SELECT] key.

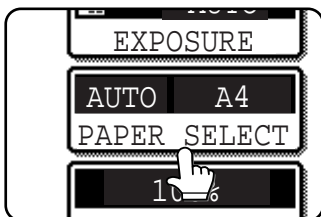

- 4 Set the type and size of paper loaded in the bypass tray.

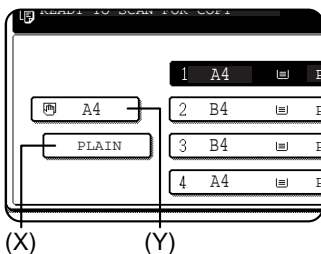

(1)The (X) key shows the currently selected paper type.

(2)The (Y) key shows the size of paper loaded in the bypass tray.

(3)To change the displayed paper type, touch the (X) key before touching the (Y) key. When loading paper, if you changed the paper size from an AB size to an inch size (or from an inch size to an AB size), or if you changed the paper type, be sure to change the paper type and size settings as explained in steps 5 to 6 on page 2-5, and steps 7 to 10 on page 2-6.

- 5 Select the bypass tray.

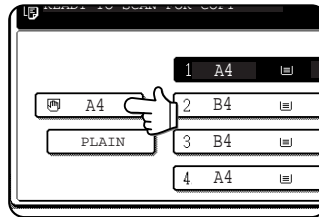

- 6 Select any desired copy settings such as the exposure or number of copies, and then press the [START] key.

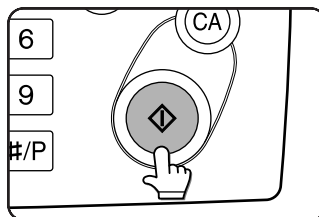

When copying from the document glass in the sort mode using the [START] key, touch the [READ-END] key after all originals have been scanned (step 8 on page 4-12).



CHAPTER 5

CONVENIENT COPY FUNCTIONS

This chapter explains special-purpose functions, storing of copy settings, and other convenient functions. Please select and read sections of this chapter as needed.

	Page
SPECIAL MODES.....	5-2
• General procedure for using special functions.....	5-2
• Margin shift.....	5-3
• Erase.....	5-4
• Dual page copy.....	5-5
• Pamphlet copy.....	5-6
• Job build.....	5-8
• Tandem copy.....	5-9
• Covers/inserts.....	5-11
• Transparency film with insert sheets.....	5-22
• Multi shot.....	5-23
• Book copy.....	5-25
• Card shot.....	5-26
• Mirror image.....	5-28
• B/W reverse.....	5-28
• Print menu.....	5-29
STORING, USING AND DELETING JOB PROGRAMS.....	5-41
• Storing a job program.....	5-41
• Calling up a job program.....	5-42
• Deleting a stored job program.....	5-42
INTERRUPTING A COPY RUN.....	5-43

SPECIAL MODES

Touch the [SPECIAL MODES] key in the main screen of copy mode to open the special modes screen. The following functions can be selected in the special modes screen.

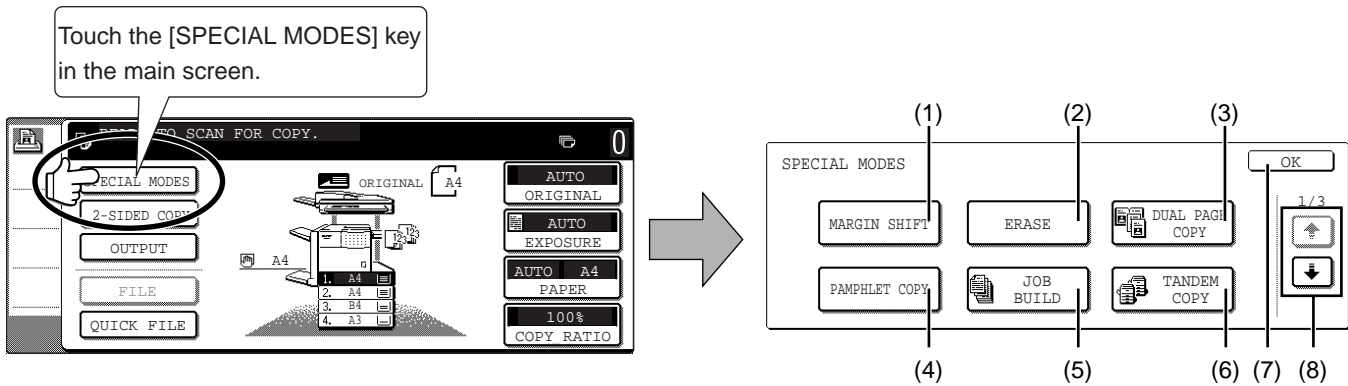

(1) Margin shift (page 5-3)

(2) Erase (page 5-4)

(3) Dual page copy (page 5-5)

(4) Pamphlet copy (page 5-6)

(5) Job build (page 5-8)

(6) Tandem copy (page 5-9)

(7) [OK] key on the special modes screen

Touch the [OK] key to return to the main screen of copy mode.

(8) / key

Touch these keys to change the special modes screen.

There are three special modes screens.

Touch the key to change to the other two screens.

● The following special functions can be selected in the 2nd screen (2/3).

Covers/inserts (page 5-11)

Transparency inserts (page 5-22)

Multi shot (page 5-23)

Book copy (page 5-25)

Card shot (page 5-26)

Mirror image (page 5-28)

● The following special functions can be selected in the 3rd screen (3/3).

B/W reverse (page 5-28)

Print menu (page 5-29)

General procedure for using special functions

1 Touch the [SPECIAL MODES] key.

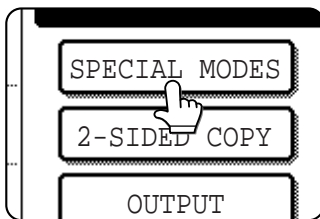

To select a special function in one of the other two screens, use the / keys to change the screen.

2 Touch the key for the desired special mode.

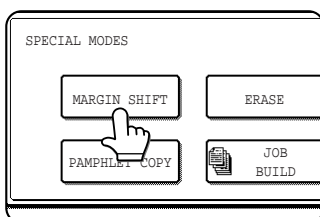

Example:
Selecting the margin shift function

Setting procedures for modes requiring setting screens start on the next page.

The dual page copy, job build, tandem copy, mirror image and B/W reverse functions do not require setting screens.

Margin shift

The margin shift function will automatically shift the text or image on the copy paper approximately 10 mm (1/2") in its initial setting.

This function is convenient when stapling or binding copies with a string.

NOTES

- The initial setting for the margin width can be changed in the key operator programs to any value from 0 to 20 mm (0 to 1"). (Page 15 of the Key operator's guide)
- When margin shift is selected, rotating copying will not operate even if the condition for rotate copying is met.

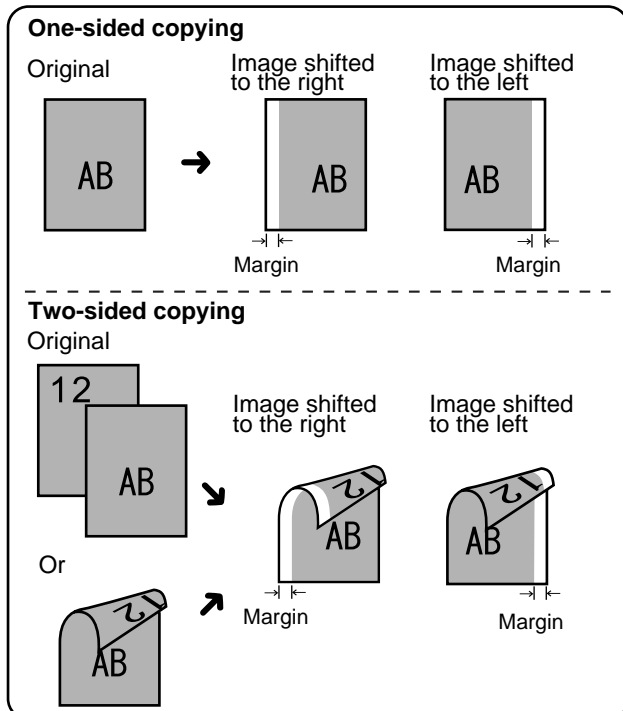

- The shift direction can be selected from right or left shift as shown in the illustration.

To display the special modes screen...

See "General procedure for using special functions" on page 5-2.

- 1 Touch the [MARGIN SHIFT] key on the special modes screen.

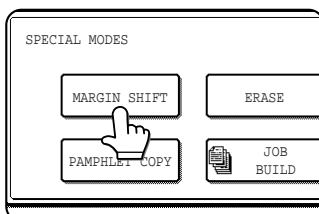

The margin shift setting screen will appear.

The margin shift icon () will also appear in the upper left of the screen to indicate that the function is turned on.

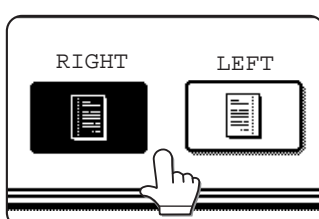

- 2 Select the shift direction.

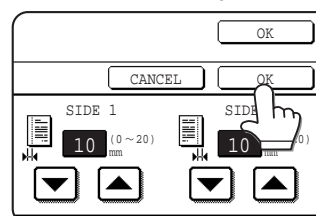

Touch a shift direction key to select right or left. The selected key will be highlighted.

- 3 Set the shift amount as needed and touch the [OK] key.



Use the  and the  keys to set the shift amount. The shift amount can be set from 0 to 20 mm in 1 mm (0" to 1" in 1/8") increments.

- 4 Touch the [OK] key on the special modes screen.

You will return to the main screen of copy mode.

About the steps that follow

If an automatic document feeder is being used, see pages 4-7 through 4-10. If the document glass is being used, see pages 4-11 through 4-13.

To cancel the margin shift function, touch the [CANCEL] key on the margin shift setting screen.

Erase

The erase function is used to erase the shadow lines on copies produced when copying thick originals or books. The erase modes that can be selected are shown below. The erase width is approximately 10 mm (1/2") in its initial setting.

NOTE
The initial setting for the erasure width can be changed in the key operator programs to any value from 0 to 20 mm (0 to 1"). (Page 15 of the Key operator's guide)

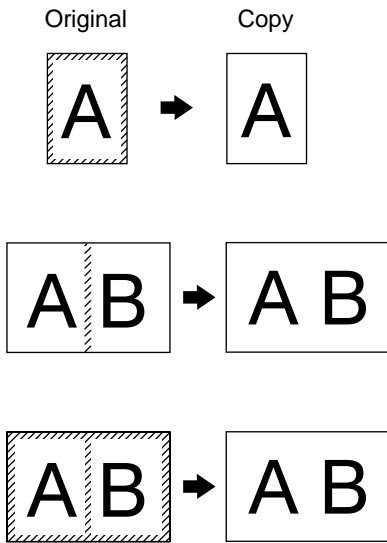

EDGE ERASE

Eliminates shadow lines around the edges of copies caused when heavy paper or a book is used as an original.

CENTRE ERASE

Eliminates shadow lines produced by the bindings of bound documents.

EDGE + CENTRE ERASE

Eliminates shadow lines around the edges of copies and eliminates the shadow at the centre of copies.

To display the special modes screen...
See "General procedure for using special functions" on page 5-2.

1 Touch the [ERASE] key on the special modes screen.

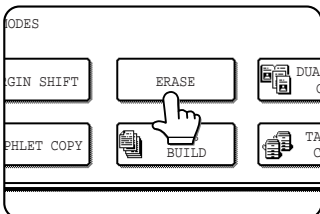

The erase setting screen will appear. The erase icon (🗑️) will also appear in the upper left of the screen to indicate that the function is turned on.

2 Select the desired erase mode.

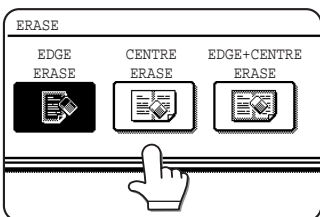

Select one of the three erase modes. The selected key will be highlighted.

3 Adjust the amount of erase and touch the [OK] key.

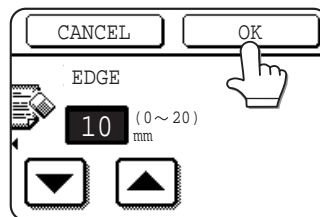

Use the ▼ and ▲ keys to set the erase width to any value from 0 to 10 mm in 1 mm increments (0" to 1" in increments of 1/8").

4 Touch the [OK] key on the special modes screen.

You will return to the main screen of copy mode.

About the steps that follow

If an automatic document feeder is being used, see pages 4-7 through 4-10. If the document glass is being used, see pages 4-11 through 4-13.

NOTE

When erase is used, edge erase takes place at the edges of the original image. If you also use a ratio setting, the edge erase width will change according to the set ratio.

To cancel the erase function, touch the [CANCEL] key on the erase setting screen (step3).

Dual page copy

The dual page copy function produces separate copies of two documents placed side by side on the document glass. This function is especially useful when copying books and other bound documents.

[Example] Copying right and left pages of a book

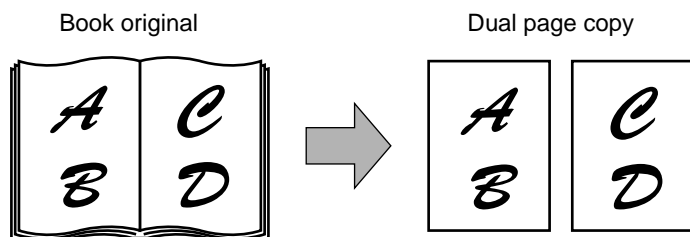

- The dual page copy function can be used only when copying from the document glass. The automatic document feeder cannot be used with this function.
- Only A4 (8-1/2" x 11") paper can be used.

To display the special modes screen...

See "General procedure for using special functions" on page 5-2.

1 Touch the [DUAL PAGE COPY] key on the special modes screen.

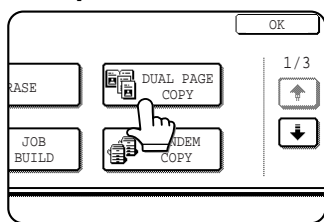

The [DUAL PAGE COPY] key will be highlighted to indicate that the function is turned on, and the dual page copy icon (📄📄) will appear in the upper left of the screen.

2 Touch the [OK] key on the special modes screen.

You will return to the main screen of copy mode.

3 Place the originals on the document glass.

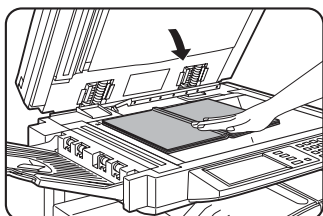

When copying a thick book, press down lightly on the book to flatten it against the document glass.

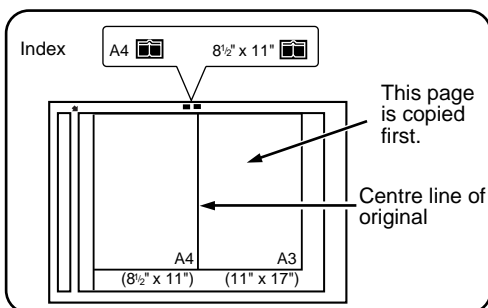

Place the opened original on the document glass so that the first page you wish to copy is on the right and the centre of the original is aligned with the size mark.

4 Ensure that 8-1/2" x 11" (A4) size paper is selected.

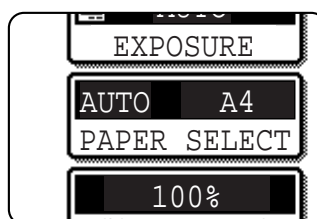

If A4 (8-1/2" x 11") size paper is not selected, touch the [PAPER SELECT] key to select A4 (8-1/2" x 11") size paper.

About the steps that follow

For two-sided copying, follow steps 2 through 4 on page 4-13 and then follow steps 4 through 7 on page 4-12.

For one-sided copying, follow steps 4 through 7 on page 4-12.

NOTE

To erase shadows caused by document binding, use the edge erase function (page 5-4). (Centre Erase and Edge + Centre Erase cannot be used in combination.)

To cancel the dual page copy function, touch the [DUAL PAGE COPY] key on the special modes screen (screen of step 1).

Pamphlet copy

The pamphlet copy function is used to arrange copies in proper order for eventual centre-stapling and folding into a booklet. Two original pages are copied onto each side of copy paper. Four pages are, therefore, copied onto one sheet. This function is convenient for arranging copies into an attractive booklet or pamphlet.

NOTE

To make pamphlet copies of a book or other bound original, use the book copy function (page 5-25). The book copy function scans the opened original in two-page units. (Two pages are scanned at each scan, reducing the number of repetitions of the scanning operation by a half.)

[Example] Copying eight originals in the pamphlet copy mode

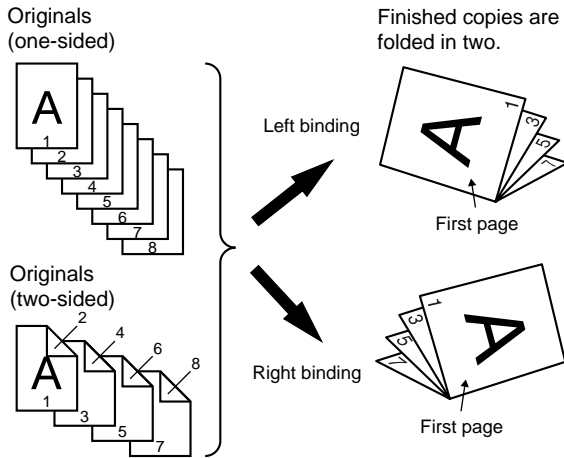

- When using this function, a duplex module must be installed.
- Scan the originals from the first page to the last page. The order of copying will be automatically adjusted by the machine.
- Either left binding (right to left turning) or right binding (left to right turning) can be selected.
- Four originals will be copied onto one sheet. Blank pages may be automatically produced at the end depending on the number of the originals.
- If a saddle stitch finisher is installed, copies can be stapled in two positions along the centre of copies and folded at the centre.

To display the special modes screen...
See "General procedure for using special functions" on page 5-2.

1 Touch the [PAMPHLET COPY] key on the special modes screen.

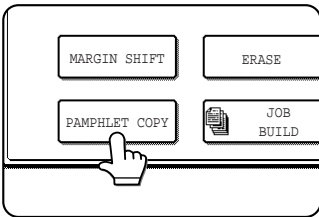

The PAMPHLET COPY setting screen will appear. The pamphlet copy icon (📄, etc.) will also appear in the upper left corner of the screen to indicate that the function is turned on.

2 Designate the type of originals to be copied: 1-sided or 2-sided.

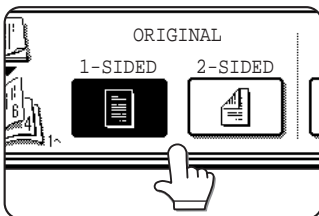

Select the [2-SIDED] key if you wish to scan a two-sided original using the automatic document feeder.

3 Select the binding position (left binding or right binding).

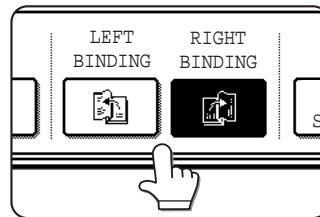

If you wish to insert a different type of paper for use as a cover, follow steps 4 through 12 below.

If you do not wish to insert paper for a cover, continue from step 8 on the next page.

4 Touch the [COVER SETTING] key.

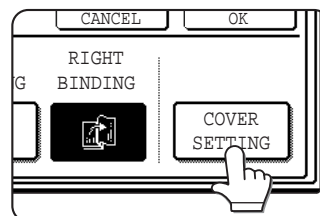

5 Select whether or not you wish to copy on the cover ("YES" or "NO").

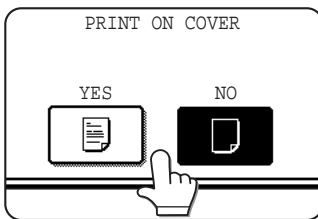

6 Select the paper tray for the cover.

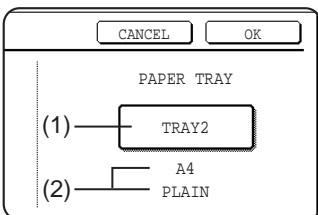

- (1) The currently selected paper tray for the cover is displayed.
- (2) The size and type of paper in the currently selected tray is displayed.

In the example screen above, A4 (8-1/2" x 11") size plain paper is loaded.

To change the paper tray for the cover, touch the tray selection key. (In the screen example, the "TRAY2" display is the tray selection key.)

The tray selection screen appears when the tray selection key is touched. Select the desired tray in this screen.

NOTES

- Two-sided copying is not possible on label sheets, and transparency film. When copying on a cover, do not select a tray that has one of these types of paper.
- Select the same size of paper for the covers as for the copies.

7 Touch the [OK] key.

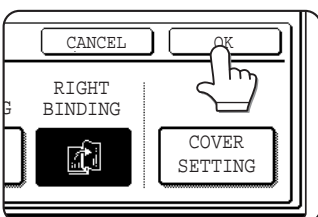

8 Touch the [OK] key.

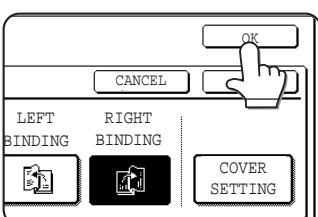

Return to the main screen of copy mode.

9 Place the original in the document feeder or on the document glass. (page 4-3)

10 Ensure that the desired paper size has been automatically selected based on the original size.

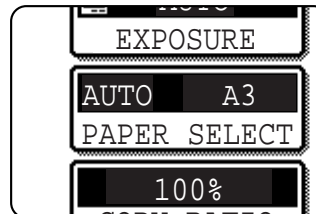

To select another size paper, select the desired size and touch the [AUTO IMAGE] key. The appropriate copy ratio will be selected automatically based on

the original size and the paper size. (See steps 2 and 3 on page 4-15.)

11 Select any desired copy settings such as the exposure or number of copies, and then press the [START] key.

12 [When using the automatic document feeder:]

Copying will start after all originals have been scanned. (The next step is not needed.)

[When using the document glass:]

Replace the original with the next original and press the [START] key. Repeat this operation until all originals have been scanned and then touch the [READ-END] key.

5

NOTES

- When the pamphlet copy function is set, the two-sided copying mode will be automatically selected.
- If this function is used in combination with the pamphlet copy function (pamphlet stapling) and the number of original pages exceeds the number of pages that can be stapled, a message asking you to select "CANCEL", "CONTINUE", or "DIVIDE" will appear. To cancel the job, select "CANCEL". To make pamphlet copies without stapling, select "CONTINUE". To divide the pages into sets that can be stapled, select "DIVIDE".

If you performed steps 4 to 6 to insert cover paper, divided stapling is not possible. You can either continue pamphlet copying without stapling, or cancel the job.

To cancel the pamphlet copy function, touch the [CANCEL] key on the pamphlet copy setting screen (step 7).

Job build

Use job build mode when you need to copy more originals than can be placed in the document feeder at once. The maximum number of originals that can be placed in the document feeder at once is 50 sheets (30 sheets when the size is B4 or larger; for more information see "Acceptable originals" on page 4-2). This function lets you divide and scan the originals in sets. This function allows the original pages to be scanned in sets.

[Example] Copying 100 pages of A4 originals

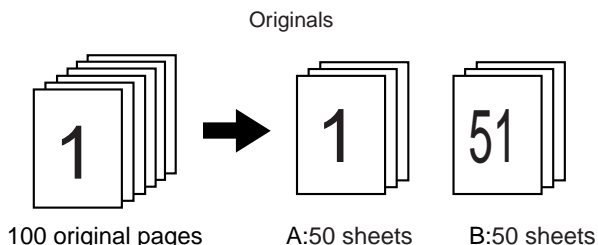

*Divide the originals into sets of 50 pages each.
Scan the originals starting from the first page of set A. Scan set B next, taking care to keep the correct page order.

To display the special modes screen...
See "General procedure for using special functions" on page 5-2.

1 Touch the [JOB BUILD] key on the special modes screen.

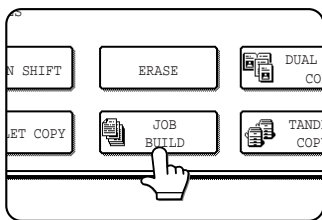

The [JOB BUILD] key will be highlighted to indicate that the function is turned on, and the job build icon (📄) will appear in the upper left of the screen.

2 Touch the [OK] key on the special modes screen.

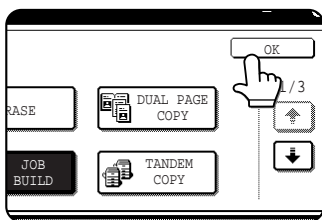

Return to the main screen of copy mode.

3 Place the first set of originals in the document feeder tray. (page 4-3)

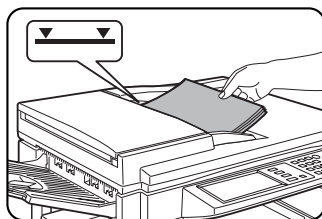

4 Make sure that the desired paper size is selected, select the number of copies or other copy settings, and press the [START] key.

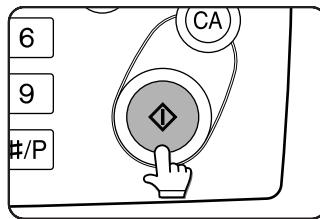

Scanning of originals will start. After scanning of the first set of originals (A in the example above) is completed, remove the scanned originals, place the next set of originals

(set B in the example) and press the [START] key. Repeat this operation until all sets of originals have been scanned.

5 Touch the [READ-END] key.

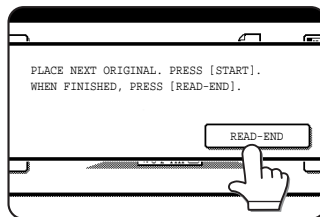

To cancel the job build function, touch the [JOB BUILD] key on the special modes screen (step 1). The highlighted display will be cancelled.

Tandem copy

Two machines connected to the same network can be used to run a large copy job in parallel.

By dividing the job in half, approximately half the time is required to complete the job.

To use this function, two machines must be connected to your network as network printers. Even if more machines are connected to the network, this function can only be used to have one other machine share a job.

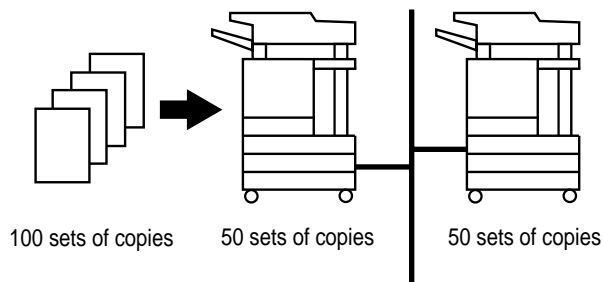

To display the special modes screen...

See "General procedure for using special functions" on page 5-2.

1 Touch the [TANDEM COPY] key on the special modes screen.

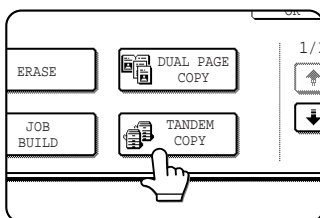

The [TANDEM COPY] key will be highlighted to indicate that the function is turned on, and the tandem copy icon (📄📄) will appear in the upper left of the screen.

2 Touch the [OK] key on the special modes screen.

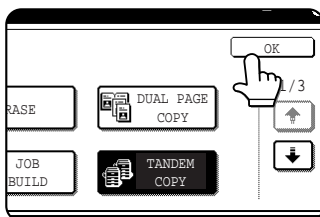

You will return to the main screen of copy mode.

Server machine and client machine

- In the following explanations, the machine on which the copy job is initially set up and tandem copy selected is called the server machine. The other machine that is asked to share the job is called the client machine.
- To use the tandem copy function, the tandem settings must be configured in the key operator programs. (See page 5-7 of the "Operation manual (for printer)")
- When configuring the tandem settings in the server machine, the IP address of the client machine must be entered. For the port number, it is best to use the initial setting (50001). Unless you experience difficulty with this setting, do not change it. The tandem settings should be configured by your network administrator. If the server and client machines will alternate server and client roles, the IP address of the server machine must also be entered in the client machine. The same port number can be set in both machines.

3 Set the number of copies with the numeric keys.

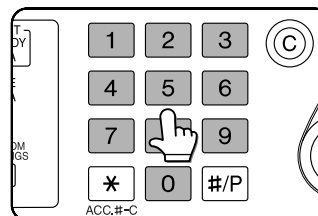

Up to 999 copies can be set. When the [START] key is pressed, the copies will automatically be divided between the server and client machines. If an odd

number of copies is set, the server machine will make the extra set.

If an incorrect number of copies is set...

Press the clear key and set the correct number of copies.

4 Place the original in the document feeder or on the document glass. (page 4-3)

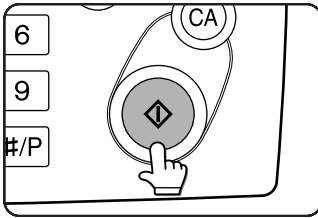
5 Press the [START] key.**NOTES**

- To perform tandem copying, the server machine and client machine must meet certain conditions. After the [START] key is pressed on the server machine, the server machine verifies that the conditions have been met. If the conditions have not been met, tandem copying does not begin and "TANDEM OUTPUT IS NOT ALLOWED. OUTPUT ALL SETS USING MASTER MACHINE?" appears in the display. To have the server machine make all the copies, touch the [OK] key. To cancel the job, touch the [CANCEL] key.
 - As an example, the following conditions must be met when a staple finisher is installed on the server machine and not on the client machine:
 - (1) If tandem copying is executed for a two-sided copy job with the number of copies set to 999 and "Non-staple" is selected, tandem copying will take place.
 - (2) If tandem copying is executed for a two-sided copy job with the number of copies set to 999 and "Staple" is selected, tandem copying will not take place because the client machine does not have a finisher.
- After the [START] key is pressed, if the client machine cannot print because it is out of paper or other reason, the server machine will print its half of the job. The other half of the job will be stored in the client machine and the job will be printed when the client machine is able to print.
- If auditing mode is enabled on both the server and client machines, the same account number must be entered on both machines.
- If auditing mode is enabled on the client machine but not on the server machine, tandem copying cannot be performed.

To cancel the tandem copy function, touch the [TANDEM COPY] key on the special modes screen (step 2). The highlighted display will be cancelled.

Covers/inserts

A different type of paper can be inserted in positions corresponding to front and back covers of a copy job when the automatic document feeder is used. A different type of paper can also be automatically added as an insert at specified pages.

- Covers/inserts can be disabled in the key operator programs (page 11 of the key operator's guide).

Example of adding covers

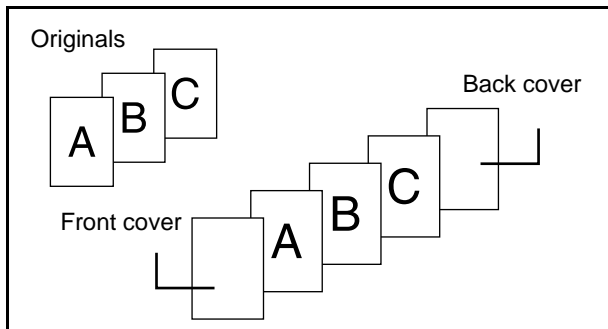

Example of adding inserts

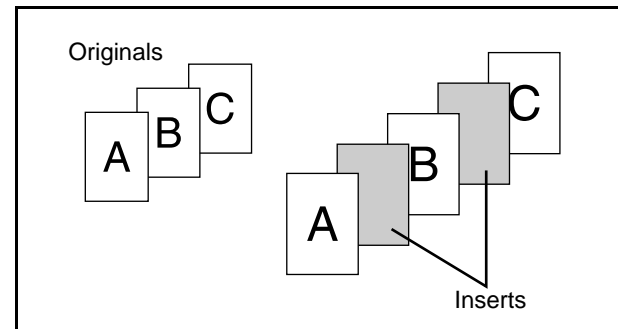

Example of adding covers and inserts

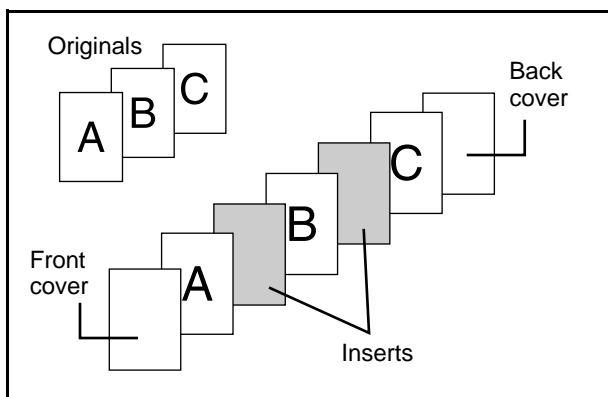

About the explanations of covers and inserts

There are various ways of using covers and inserts. To keep the explanations simple, covers and inserts are explained separately. The procedure for inserting covers is explained on page 5-12. The procedure for adding inserts is explained on page 5-13. After reading these explanations, see the examples of using covers and inserts on pages 5-16 to 5-21.

■ Preparations for using covers and inserts

- Load the cover/insert paper in the tray before using the cover/insert function.
- Use the same size of paper for the covers/inserts as for the copies. (For the procedures for loading paper, see pages 2-2 to 2-7.)
- Before selecting the cover/insert function, place the originals in the document feeder, select one-sided or two-sided copying, and select the number of copies and any other desired copy settings as explained on pages 4-7 to 4-10. When these settings have been completed, perform the procedure to select covers/inserts on the following page.
- The original must be scanned from the document feeder. The document glass cannot be used.
- Up to 100 covers/inserts can be inserted. Two covers/inserts cannot be inserted between the same pages.
- Pamphlet copying cannot be used in combination with covers/inserts.
- When performing two-sided copying of two-sided originals, an insert cannot be added between the front and back sides of an original page.

■ Procedure for inserting front and back cover paper

The paper for the front cover is called the front cover paper ("FRONT COVER" in the touch panel). The paper for the back cover is called the back cover paper ("BACK COVER" in the touch panel).

- Examples of insertion methods for the front and back cover paper are given on pages 5-17 to 5-20.

To display the special modes screen...
See "General procedure for using special functions" on page 5-2.

1 Touch the [COVERS/INSERTS] key in the special modes screen (2nd screen).

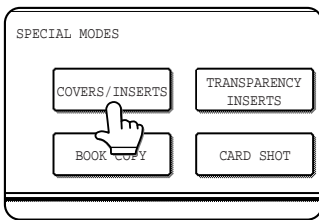

2 Touch the [PAPER TRAY SETTINGS] key.

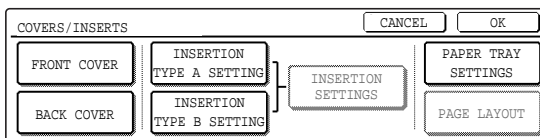

3 Select the tray used for the front cover paper.

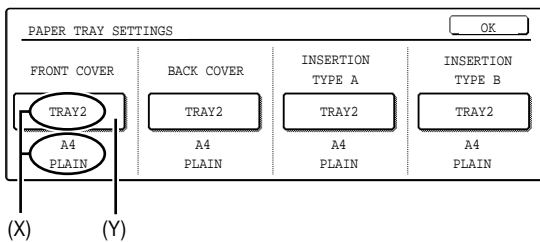

- (1) The tray name (tray position) selected for the front cover paper and the paper size and type are shown in (X). If the tray in which you loaded paper for the front cover is shown, touch the [OK] key. You will return to the screen of step 2.
- (2) If the correct tray for the cover sheet paper does not appear in (X), touch the (Y) key. The tray selection screen will appear. Select the tray in which you loaded paper for the front cover. You will return to the screen of above.

4 Touch the [FRONT COVER] key in the screen of step 2.

5 Set the insertion conditions for the front cover paper.

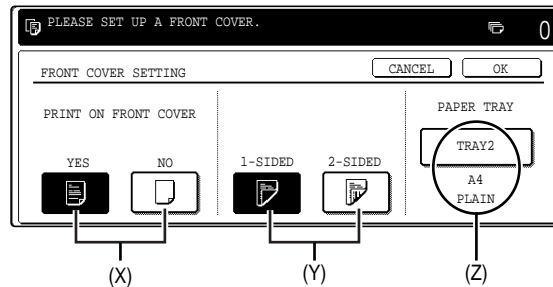

- (1) Select whether or not the front cover paper is to be copied on with the (X) keys ([YES] or [NO]).
- (2) Select whether one-sided copying or two-sided copying is to be performed on the front cover paper with the (Y) keys. This selection is only possible when the [YES] key of (X) has been selected. (The one-sided/two-sided selection made here only applies to the front cover paper. When the back cover paper is selected, the selection only applies to the back cover paper.)
- (3) The (Z) key shows the tray selected for the front cover paper in step 3 and the paper size and type.

6 Touch the [OK] key in the screen of step 5. You will return to the screen of step 2.

When you return to the screen of step 2, the [FRONT COVER] key will be highlighted.

7 To insert back cover paper, repeat steps 2 through 6, using the [BACK COVER] key instead of the [FRONT COVER] key.

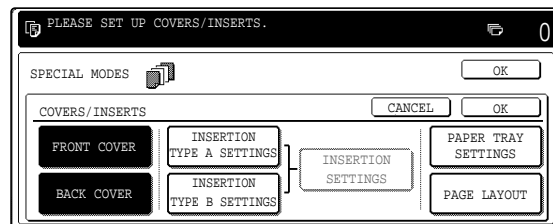

8 Touch the [PAGE LAYOUT] key in the screen of step 7 to display a list of the selected settings (page 5-15).

To exit the cover/insert settings, touch the upper [OK] key in the screen of step 7.

9 Press the [START] key.

To cancel covers/inserts settings...
Touch the [CANCEL] key in the screen of step 2.

■ Procedure for adding inserts

You can have different paper automatically inserted as an insert at a specified pages. Two types of insert paper can be used. These are specified with the [INSERTION TYPE A SETTING] key and [INSERTION TYPE B SETTING] in the touch panel.

● Examples of insertion methods for insert paper are given on page 5-21.

To display the special modes screen...
See "General procedure for using special functions" on page 5-2.

1 Touch the [COVERS/INSERTS] key in the special modes screen (2nd screen).

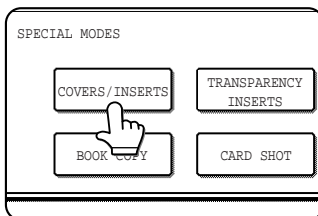

2 Touch the [PAPER TRAY SETTINGS] key.

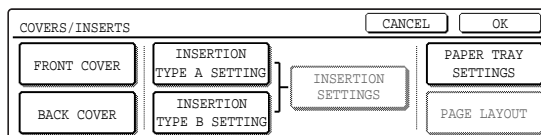

3 Select the tray used for insertion type A.

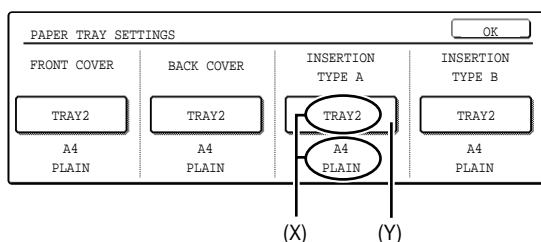

- (1) The tray name (tray position) selected for insertion type A and the paper size and type are shown in (X). If the tray in which you loaded paper for insertion type A is shown, touch the [OK] key. You will return to the screen of step 2.
- (2) If the correct tray for insertion type A does not appear in (X), touch the (Y) key. The tray selection screen will appear. Select the tray in which you loaded paper for insertion type A. You will return to the screen of step 2.

4 Touch the [INSERTION TYPE A SETTING] key in the screen of step 2

5 Set the insertion conditions for insertion type A.

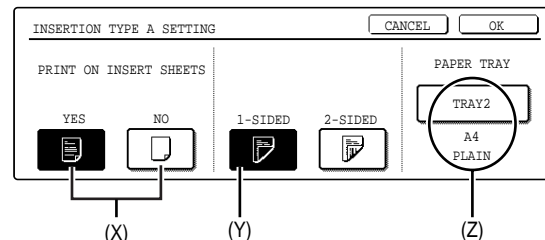

- (1) Select whether or not insertion type A paper is to be copied on with the (X) keys ([YES] or [NO]).
- (2) Select whether one-sided copying or two-sided copying is to be performed on insertion type A with the (Y) keys. This selection is only possible when the [YES] key of (X) has been selected. (The one-sided/two-sided selection made here only applies to insertion type A paper. When insertion type B is selected, the selection only applies to insertion type B paper.) The [2-SIDED] key appears when the duplex module is installed.
- (3) The (Z) key shows the tray selected for insertion type A in step 3 and the paper size and type.

6 Touch the [OK] key in the screen of step 5. You will return to the screen of step 2.

When you return to the screen of step 2, the [INSERTION TYPE A SETTING] key will be highlighted.

7 If you wish to insert a different paper with the [INSERTION TYPE B SETTING] key, repeat steps 2 through 6. Use the [INSERTION TYPE B SETTING] key instead of the [INSERTION TYPE A SETTING] key, and the [INSERTION TYPE B] key instead of the [INSERTION TYPE A] key.

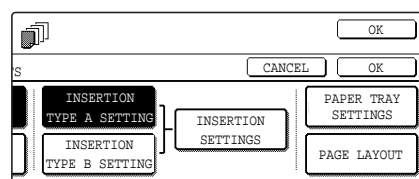

5

- 8 Touch the [INSERTION SETTINGS] key to specify the pages where you wish to insert the insert papers of [INSERTION TYPE A SETTING] and [INSERTION TYPE B SETTING].

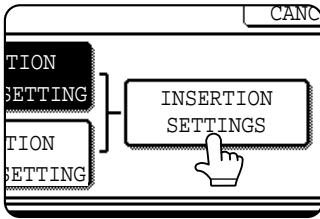

- 9 Touch the [INSERTION TYPE A] key or the [INSERTION TYPE B] key, enter the page number where you wish to insert the insert paper with the numeric keys, and then touch the [ENTER] key.

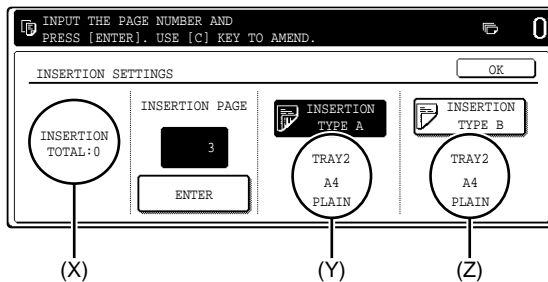

- (1)(X) shows the total number of inserts. Up to 100 inserts can be added. When inserting multiple inserts, touch the [ENTER] key after each entry of an insertion page number (insertion position) with the numeric keys.
- (2)(Y) shows the tray selected in step 3 for [INSERTION TYPE A SETTING] and the paper size and type.
- (3)(Z) shows the tray selected in step 3 for [INSERTION TYPE B SETTING] and the paper size and type.
- (4)When the [INSERTION TYPE A] key is highlighted, the insert settings apply to [INSERTION TYPE A SETTING]. When the [INSERTION TYPE B] key is highlighted, the insert settings apply to [INSERTION TYPE B SETTING].

- 10 Touch the [OK] key in the screen of step 9. You will return to the screen of step 2.

- 11 If you wish to insert a different paper with the [INSERTION TYPE B SETTING] key, repeat steps 2 through 6. Use the [INSERTION TYPE B SETTING] key instead of the [INSERTION TYPE A SETTING] key, and the [INSERTION TYPE B] key instead of the [INSERTION TYPE A] key.

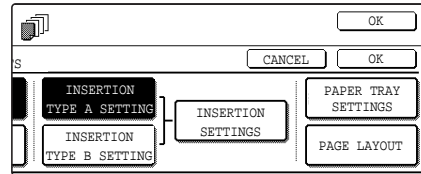

- 12 Touch the [PAGE LAYOUT] key in the screen of step 11 to display a list of the selected settings (page 5-15).

To exit the cover/insert settings, touch the upper [OK] key in the screen of step 11.

- 13 Press the [START] key.

To cancel covers/inserts settings...
Touch the [CANCEL] key in the screen of step 2.

■ Checking, editing, and deleting cover/insert pages

The [PAGE LAYOUT] key appears after covers/inserts settings are configured (the settings of step 1 through step 7 on pages 5-12 and 5-13).

The [PAGE LAYOUT] key is used for the following:

- To display the status of covers/inserts pages
- To edit, delete, or add inserted pages

To display the [PAGE LAYOUT] key...

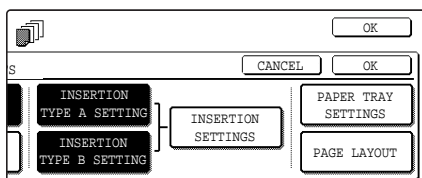

Configure the settings in step 1 through step 7 on pages 5-12 and 5-13.

1 Touch the [PAGE LAYOUT] key.



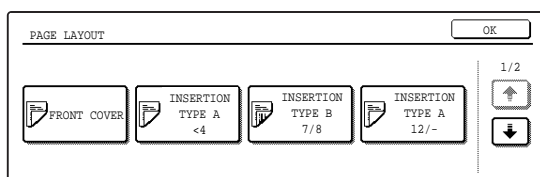



2 The set covers/inserts pages are shown.



(1) If there are multiple screens, touch the  or  key to change screens.

(2) Displayed icons:

-  : Front side copy only
-  : Back side copy only
-  : Two-sided copy
-  : No copying

For inserts, the insertion page also appears.

"*" represents a page number.

- */- : Front side copy only at page *
- */* : Two-sided copy at page */*
- <* : Insert non-copied insert at page *

(3) To edit or delete the insertion page of an insert, touch the key of the insert that you wish to edit or delete in the page layout screen. When the key is touched, the [CANCEL], [DELETE], or [AMEND] keys appear.

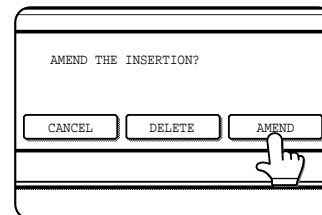

● To cancel, touch the [CANCEL] key.

● To delete an inserted page, touch the [DELETE] key.

● To edit an inserted page, touch the [AMEND] key. The screen of step 9 on page 5-14 appears. Edit the insertion page in the screen that appears.

(4) To edit or delete a cover page, touch the [BACK COVER] key in the page layout screen. The screen of step 5 on page 5-12 will appear. Edit or delete the cover page in this screen.

3 When you have finished checking the pages, touch the [OK] key.

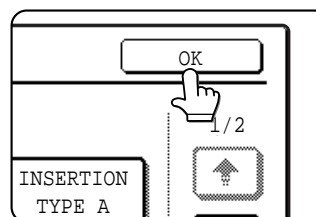

■ **Examples of covers and inserts**

The relations between the originals and finished copies when covers or inserts are inserted are shown on the following pages.

Covers

- One-sided copying of one-sided originals (page 5-17)
- One-sided copying of two-sided originals (page 5-19)

- Two-sided copying of one-sided originals (page 5-18)
- Two-sided copying of two-sided originals (page 5-20)

Inserts

- One-sided copying of one-sided originals (page 5-21)
- One-sided copying of two-sided originals (page 5-21)

- Two-sided copying of one-sided originals (page 5-21)
- Two-sided copying of two-sided originals (page 5-21)

■ **Symbols used for covers and inserts**

The following symbols are used to make the explanations easier to understand.



















The numbers that appear indicate relations between the originals and copies, and will vary depending on the settings.

Type	Symbol	Meaning	Icon appearing in display	Type	Symbol	Meaning	Icon appearing in display
Front cover		Front cover when not copied on.		Inserts		Insert when not copied on.	
		Front cover after one-sided copying.				Insert after one-sided copying.	
		Front cover after one-sided copying of a two-sided original. (One page is not copied on.)				Insert after one-sided copying of a two-sided original. (One page is not copied on.)	
		Front cover after two-sided copying.				Insert after two-sided copying.	
Back cover		Back cover when not copied on.		Other		One-sided original or output page of regular one-sided copying	
		Back cover after one-sided copying of one-sided original.				Two-sided original or output page of regular two-sided copying.	
		Back cover after one-sided copying of a two-sided original. (One page is not copied on.)				One-sided original or output page of regular one-sided copying.	
		Back cover after two-sided copying.				Two-sided copy when only one side is copied on due to insufficient originals.	

■ **Covers (One-sided copying of one-sided originals)**

One-sided copies are made of the following one-sided originals.

1st page	2nd page	3rd page	4th page	5th page	6th page
1	2	3	4	5	6

Copying on cover		Resulting copies							
Front cover	Back cover								
No copying	No copying		1	2	3	4	5	6	
One-sided copying	No copying		2	3	4	5	6		
Two-sided copying	No copying		3	4	5	6			
No copying	One-sided copying		1	2	3	4	5		
No copying	Two-sided copying		1	2	3	4			
One-sided copying	One-sided copying		2	3	4	5			
One-sided copying	Two-sided copying		2	3	4				
Two-sided copying	One-sided copying		3	4	5				
Two-sided copying	Two-sided copying		3	4					

■ **Covers (Two-sided copying of one-sided originals)**



Two-sided copies are made of the following one-sided originals.





























































1st page	2nd page	3rd page	4th page	5th page	6th page
1	2	3	4	5	6

Copying on cover		Resulting copies
Front cover	Back cover	
No copying	No copying	
One-sided copying	No copying	
Two-sided copying	No copying	
No copying	One-sided copying	
No copying	Two-sided copying	
One-sided copying	One-sided copying	
One-sided copying	Two-sided copying	
Two-sided copying	One-sided copying	
Two-sided copying	Two-sided copying	

■ **Covers (One-sided copying of Two-sided originals)**



One-sided copies are made of the following two-sided originals.

1st page	2nd page	3rd page
		

Copying on cover		Resulting copies							
Front cover	Back cover								
No copying	No copying								
One-sided copying	No copying								
Two-sided copying	No copying								
No copying	One-sided copying								
No copying	Two-sided copying								
One-sided copying	One-sided copying								
One-sided copying	Two-sided copying								
Two-sided copying	One-sided copying								
Two-sided copying	Two-sided copying								

■ **Covers (Two-sided copying of two-sided originals)**





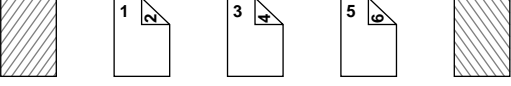
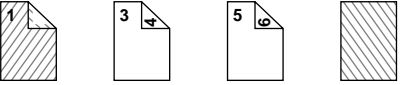
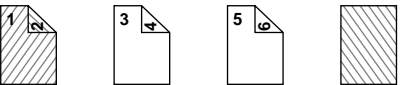
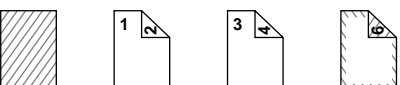
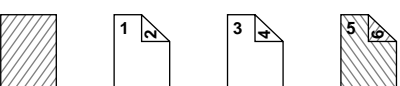
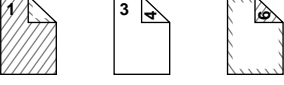
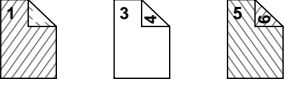
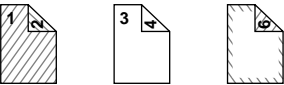
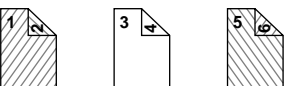

Two-sided copies are made of the following two-sided originals.





































1st page	2nd page	3rd page
		

Copying on cover		Resulting copies
Front cover	Back cover	
No copying	No copying	
One-sided copying	No copying	
Two-sided copying	No copying	
No copying	One-sided copying	
No copying	Two-sided copying	
One-sided copying	One-sided copying	
One-sided copying	Two-sided copying	
Two-sided copying	One-sided copying	
Two-sided copying	Two-sided copying	

■ **Inserts (One-sided copying of one-sided originals)**



One-sided and two-sided copying is performed using the following one-sided originals. The insertion page of the insert is set to page 3.





































1st page	2nd page	3rd page	4th page	5th page	6th page
					

Copying on insert	Resulting copies (one-sided copying)						Resulting copies (two-sided copying)					
No copying												
One-sided copying												
Two-sided copying												

■ **Inserts (One-sided copying of two-sided originals)**

One-sided and two-sided copying is performed using the following two-sided originals. The insertion page of the insert is set to page 3

1st page	2nd page	3rd page
		

Copying on insert	Resulting copies (one-sided copying)						Resulting copies (two-sided copying)					
No copying												
One-sided copying												
Two-sided copying												

Transparency film with insert sheets

When copying onto transparency film, blank insert sheets can be placed between transparent sheets.

Example: Inserting insert sheets between transparencies

Originals (1-sided)

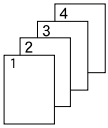

Originals (2-sided)



Two-sided originals are only supported when automatic document feeder is used.

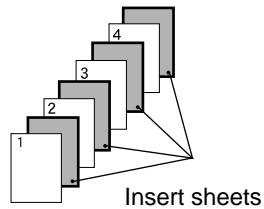

Inserts can also be copied on.

- This function only operates in "one-sided to one-sided" and "two-sided to one-sided" modes.
- Multiple copies cannot be selected in this mode.
- The inserts are inserted under each transparency as shown at left.
- Select insert paper that is the same size as the transparencies.
- Transparencies can be fed from the tray 2 or bypass tray.
- If the transparencies are loaded in tray 2, be sure to set the paper size and paper type as explained on pages 2-5 and 2-6.

1 Load transparency film into the tray 2.

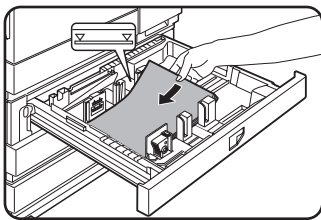

Remove any paper already in the tray 2 before loading the transparency film. (To load paper in the tray 2, see pages 2-6 and 2-7.)

2 Press the [CUSTOM SETTINGS] key.

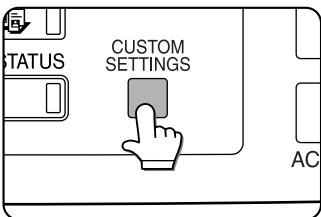

The custom settings menu screen will appear.

3 Touch the [PAPER TRAY SETTINGS] key.

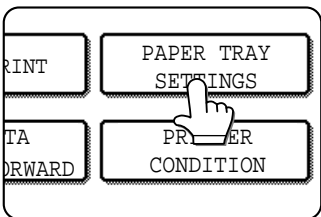

The paper tray selection screen will appear.

4 Touch the [TRAY SETTINGS] key.

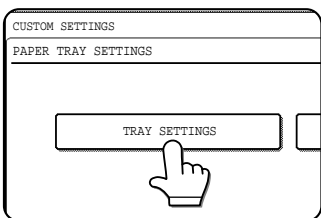

5 Touch the [DOWN] key to display the tray settings screen of tray 2.

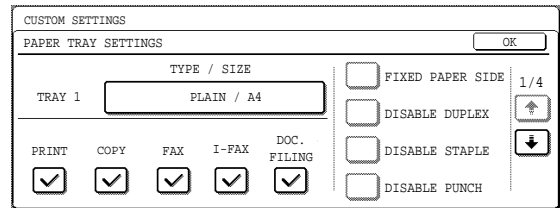

6 Touch the [TYPE/SIZE] key.

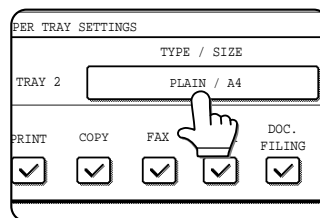

7 Touch the [TRANSPARENCY] key.

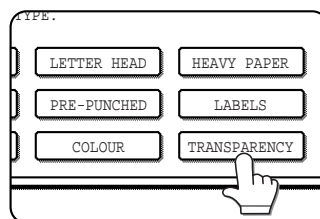

8 Touch the [OK] key.

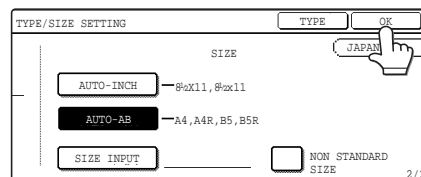

If the paper size was changed from an AB size to an inch size, or from an inch size to an AB size, be sure to set the paper type and size as explained on steps 5 to 6 on page 2-5 and steps 7 to 10 on page 2-6.

9 Select the tray 2.

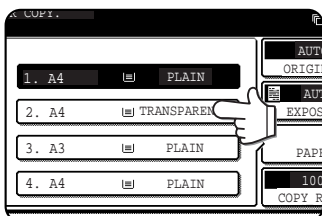

To display the special modes screen...
See "General procedure for using special functions" on page 5-2.

10 Touch the [TRANSPARENCY INSERTS] key in the special modes screen (2nd screen).

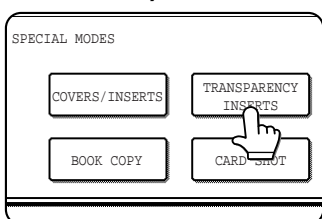

The Transparency inserts setting screen will appear. The transparency inserts icon (☐), etc.) will also appear in the upper left corner of the screen to indicate that the function is turned on.

11 Set the insertion conditions for the insert paper.

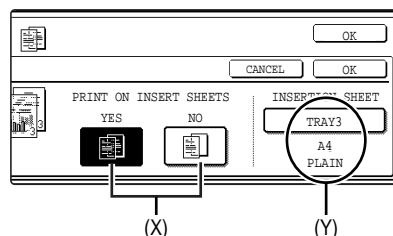

- (1) Select whether or not the insert paper will be copied on with the (X) keys ([YES] or [NO]).
- (2) The (Y) key shows the tray selected for the insert paper and the paper size and type. To select a different tray, touch this key to display the tray selection screen and select the tray that has the insert paper.

12 Touch the outer [OK] key in the screen of step 7.

You will return to the main screen of copy mode.

About the steps that follow

If an automatic document feeder is being used, see pages 4-7 through 4-10. If the document glass is being used, see pages 4-11 through 4-13.

To cancel the Transparency film with insert sheets function, touch the [CANCEL] key on the Transparency film with insert sheets setting screen.

Multi shot

Multiple original pages can be copied onto one sheet of copy paper in a uniform layout. Select 2in1 to copy two original pages onto one sheet, or 4in1 to copy four original pages onto one sheet. This function is convenient when you wish to present multiple pages in a compact format, or show a view of all pages in a document.

[Example] Copying 4 original pages onto one sheet of paper
(Page number : 4in1, layout : left top : right top (see the next page))

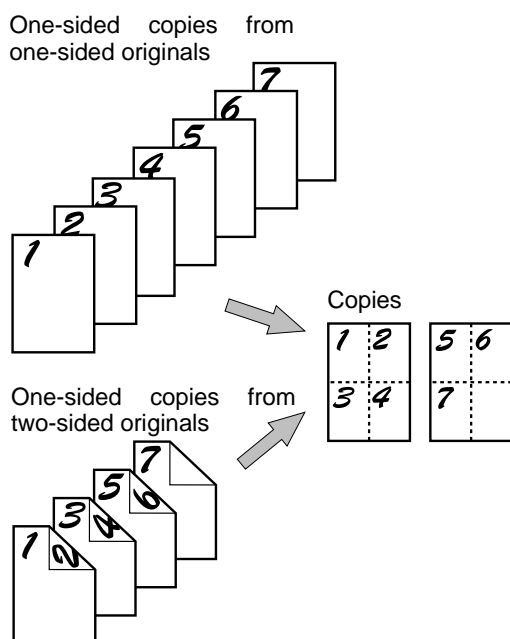

- When using the multi shot function, place the originals, select the desired paper size, and select the copying mode before selecting the multi shot function on the special modes screen.
- When using the multi shot function, the appropriate copy ratio will be automatically set based on the original size, paper size, and the number of originals to be copied onto one sheet. The minimum reduction ratio is 25%. The original size, copy paper size, and selected number of original pages may require that the ratio be less than 25%. As copying will take place at 25% in this case, part of the original images may be cut off.

To display the special modes screen... See "General procedure for using special functions" on page 5-2.

1 Touch the [MULTI SHOT] key in the special modes screen (2nd screen).

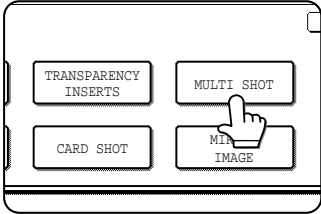

The MULTI SHOT setting screen will appear. A multi shot icon (1/2, 3/4, etc.) will also appear in the upper left of the screen to indicate that the function is turned on.

2 Select the number of images to be copied onto one sheet of copy paper.

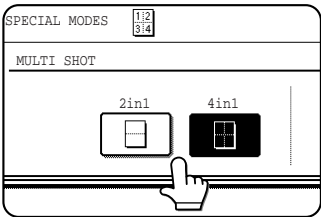

If needed, the orientation of the copy paper and the orientation of the images will be rotated.

3 Select the layout.

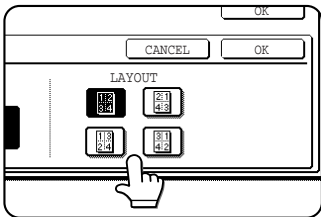

Select the order in which the originals will be arranged on the copy.

4 Touch the [OK] key (inside [OK] key) on the multi shot setting screen.

You will return to the special modes screen.

5 Touch the [OK] key in the special modes screen.

You will return to the main screen of copy mode.

About the steps that follow

If an automatic document feeder is being used, see pages 4-7 through 4-10. If the document glass is being used, see pages 4-11 through 4-13.

To cancel the multi shot function, touch the [CANCEL] key in the multi shot setting screen (the screen of step 2).

Shot number	Layout
2in1	
4in1	

The arrows in the above diagram indicate the directions in which the images are arranged.

Book copy

This function is convenient when you wish to compile copies of books or other bound originals into an attractive pamphlet format. The two pages of the open book are scanned as a set, and two pages each are copied onto the front and back sides of the copy paper (four pages are copied onto one sheet of copy paper). This allows the copies to be folded down the centre and made into a pamphlet.

[Example] Book copying an 8-page pamphlet

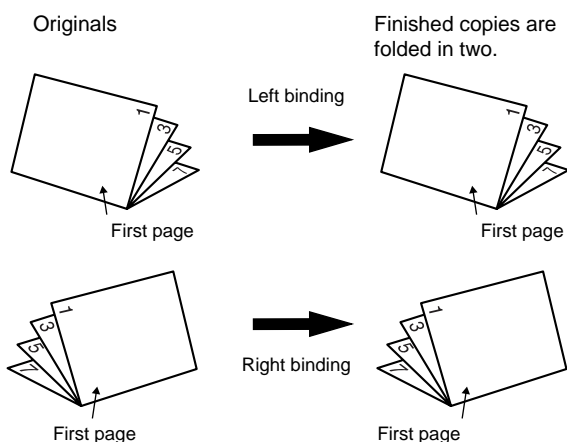

- When using this function, a duplex module must be installed.
- Scan the originals from the first page to the last page. The order of copying will be automatically adjusted by the machine.
- Either left binding (right to left turning) or right binding (left to right turning) can be selected.
- Four originals will be copied onto one sheet. Blank pages may be automatically produced at the end depending on the number of the originals.
- If a saddle stitch finisher is installed, book copy can be used in combination with the pamphlet function to staple and fold the copies at the centreline.

To display the special modes screen...
See "General procedure for using special functions" on page 5-2.

1 Touch the [BOOK COPY] key in the special modes screen (2nd screen).

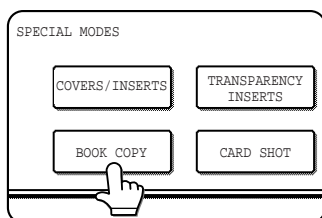

The BOOK COPY setting screen will appear. The book copy icon (, etc.) will also appear in the upper left corner of the screen to indicate that the function is turned on.

2 Select whether the book opens to the left or to the right, and touch the [OK] key in the book copy setting screen.

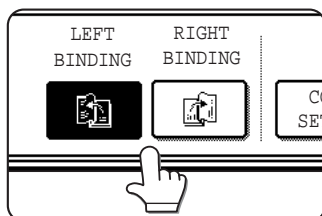

You will return to the special modes screen.

3 Select any desired cover settings.

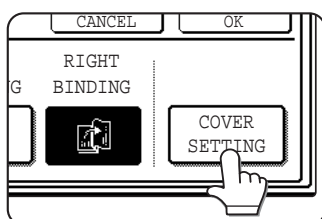

If you wish to use a different type of paper for the cover, perform steps 4 to 12 on pages 5-6 to 5-7.

If you do not wish to use a different type of paper, continue from step 4.

4 Touch the [OK] key in the special modes screen.

You will return to the main screen of copy mode.

5 Place the originals on the document glass. (page 4-3)

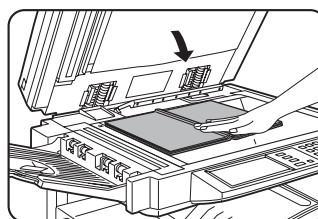

Scan the original pages in the following order:

Opened front and back cover

Opened inside of front cover and 1st page

Opened 2nd and 3rd page

⋮

Opened last page and inside of back cover

6 Make sure that the desired paper size has been selected.

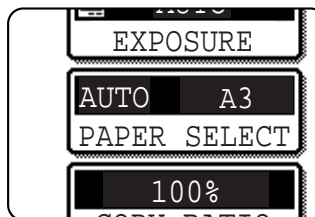

If the desired paper size is not selected, select the desired size.

7 Select the number of copies and any other desired copy settings, and then press the [START] key.

8 Place the next two pages and press the [START] key. Repeat until all pages have been scanned, and then touch the [READ-END] key.

When book copy is selected, two-sided copying is automatically selected.

To cancel the book copy function, touch the [CANCEL] key in the book copy setting screen (the screen of step 2).

Card shot

When copying a card, this function allows you to combine the front and back sides on a single sheet of paper. This function is convenient for making copies for certification purposes and helps save paper.

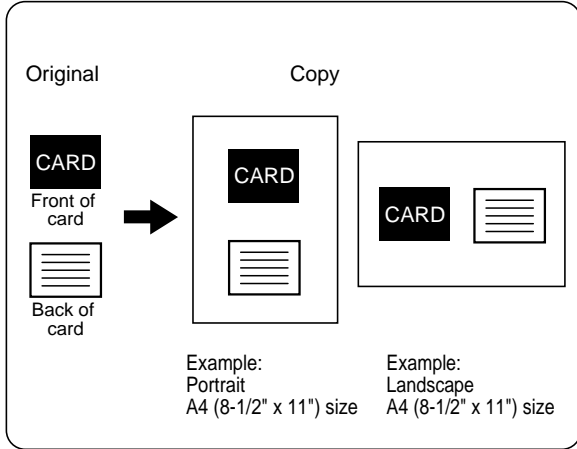

- Copying is only possible on standard size paper.
- A copy ratio cannot be selected when using this function.
- The image cannot be rotated when using this function.

1 Touch the [PAPER SELECT] key and then select the desired paper size.

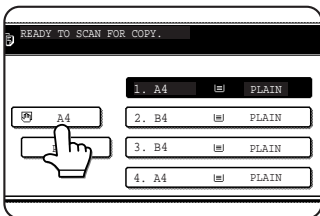



The selected paper size key is highlighted and the paper selection screen closes.

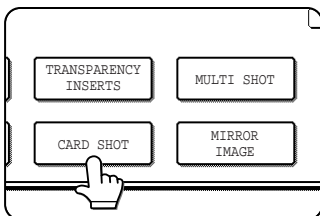

NOTE
If paper of the desired size is not loaded in any tray, load paper of the required size in a paper tray or the bypass tray. (See "Setting the paper type and paper size" on page 2-5.)

To display the special modes screen...
See "General procedure for using special functions" on page 5-2.

2 Touch the [CARD SHOT] key in the special modes screen (2nd screen).



The CARD SHOT setting screen will appear. A card shot icon (, etc.) will also appear in the upper left corner of the screen to indicate that the function is turned on.

3 Enter the X dimension (width) and Y dimension (length) of the original with the   keys.

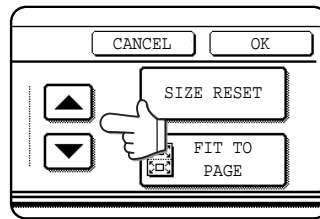

- X (width) is initially selected. Enter X and then touch the Y () key to enter Y.
- To return the X and Y values to the initial settings configured in the key operator programs, touch the [SIZE RESET] key. ("CARD SHOT SETTINGS" on page 15 of the key operator's guide).
- To have the images enlarged or reduced by a suitable ratio based on the entered original size so that the front and back sides fit into the selected paper size, touch the [FIT TO PAGE] key.

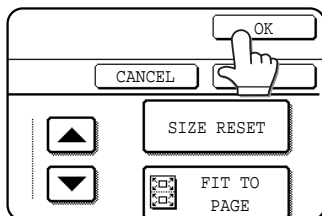
4 Touch the outer [OK] key.

You will return to the main screen of copy mode.

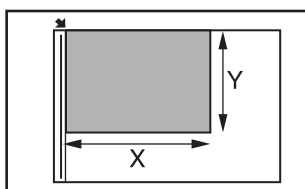
5 Place the original on the document glass.

Place the front side of the original face down and close the document cover.

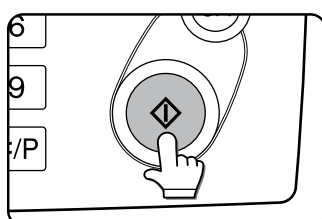
6 Follow steps 4 through 6 of "Copying from the document glass" (page 4-11).**7** Press the [START] key.

The front side of the card is scanned.

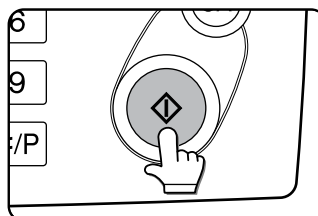
8 Place the back side of the original face down on the document glass (see step 5).**9** Press the [START] key.

The back side of the card is scanned.

10 Touch the [READ-END] key.**NOTE**

The original must be placed on the document glass. The document feeder (automatic document feeder) cannot be used.

To cancel the card shot function, touch the [CANCEL] key in the card shot setting screen (the screen of step 4).

Mirror image

This function is used to print a mirror image of the original. The images will be inverted in the right to left direction on the copies.

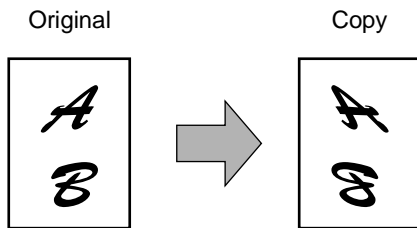

To display the special modes screen...
See "General procedure for using special functions" on page 5-2.

1 Touch the [MIRROR IMAGE] key in the special modes screen (2nd screen).

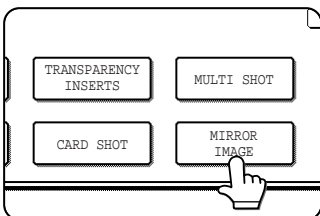

The [MIRROR IMAGE] key will be highlighted to indicate that the function is turned on, and the mirror image icon () will appear in the upper left of the screen.

2 Touch the [OK] key on the special modes screen.

You will return to the main screen of copy mode.

About the steps that follow

If an automatic document feeder is being used, see pages 4-7 through 4-10. If the document glass is being used, see pages 4-11 through 4-13.

To cancel the mirror image function, touch the [MIRROR IMAGE] key in the special modes screen (the screen of step 1).

B/W reverse

Black and white are reversed in the copy to create a negative image.

NOTES

- When this function is selected, the exposure mode setting (page 4-14) automatically changes to "Text".
- Originals with large black areas (which use a large amount of toner) can be printed with black/white reverse to reduce toner consumption.

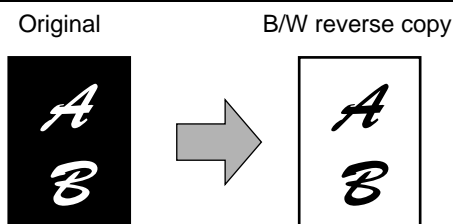

To display the special modes screen...
See "General procedure for using special functions" on page 5-2.

1 Touch the [B/W REVERSE] key in the special modes screen (3rd screen).

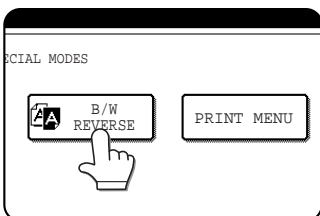

The [B/W REVERSE] key will be highlighted to indicate that the function is turned on, and the mirror image icon () will appear in the upper left of the screen.

2 Touch the [OK] key in the special modes screen.

You will return to the main screen of copy mode.

About the steps that follow

If an automatic document feeder is being used, see pages 4-7 through 4-10. If the document glass is being used, see pages 4-11 through 4-13.

To cancel the B/W reverse function, touch the [B/W REVERSE] key in the special modes screen (the screen of step 1).

Print menu

The date, a stamp, page numbers, and entered text can be printed on copies. Four selections are available for the PRINT MENU:

- **Date print (page 5-32)**

This prints the date on the paper.

[Example] Printing 2004/OCT/1 in the upper right-hand corner of the paper

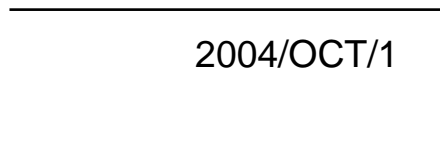

The format of the date and the character that separates the year, month, and day can be changed.

- **Page numbering (page 5-34)**

Page numbers can be printed on copies.

[Example] Printing page numbers in the bottom right-hand corner of the paper

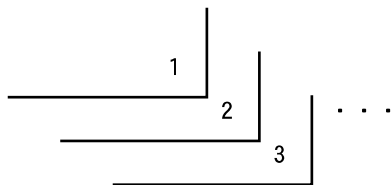

The format of the page number can be changed.

- **Stamp (page 5-33)**

Print a message such as "CONFIDENTIAL" in reverse text on the paper.

[Example] Printing "CONFIDENTIAL" in the upper right-hand corner of the paper



One of 12 stamps can be selected.

- **Text (page 5-38)**

Entered text can be printed.

[Example] Printing "October, 2004 Meeting" in the upper left-hand corner of the paper



Up to 50 characters can be printed. You can store up to 30 sequences of frequently used text.

Six printing positions are available: left, centre, or right of the top or bottom of the page.

Each printing position is divided into an area for the date, page number, and text (A below), and an area for the stamp (B below).

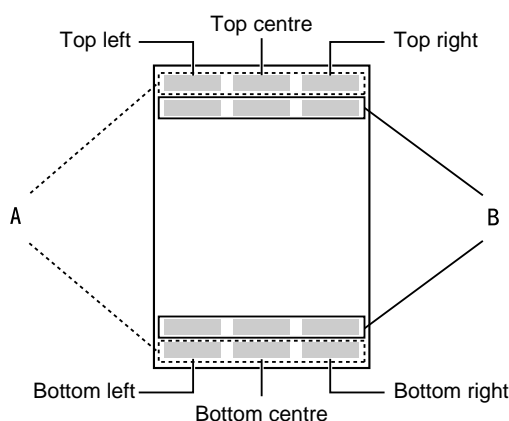

Print menu	Printing area	Maximum number of settings
DATE	A	One position only
STAMP	B	6 positions
PAGE NUMBERING	A	One position only
TEXT	A	6 positions

NOTES

- A part that overlaps the printed text will not be copied.
- If the set text content overlaps the print content of another position, the central print content will be moved to the bottom, the content on the left will be next, and the content on the right will be placed on top in that order such that only the content visible at the top is printed. Content that is hidden due to overlapping will not be printed.
- The printed text will be printed at the set size regardless of the copy ratio or paper size.
- The printed text will also be printed at the set density regardless of the copy exposure.
- Some copy paper sizes may cause the printed contents to be cut off or the print position to shift.
- If a copy job with a print menu setting is saved using the document filing function, the print menu setting will not be saved. If you wish to print a file saved in copy mode and use a print menu setting, use the special modes in the Job settings / print screen (or the document filing print screen in the Web page if the machine is connected to a network) to select the print menu setting. (A print menu setting cannot be selected when printing a file saved in a mode other than copy mode.)

■ Common operation procedure for using the print menu

To display the special modes screen...
See "General procedure for using special functions" on page 5-2.

1 Touch the [PRINT MENU] key in the special modes screen (3rd screen).

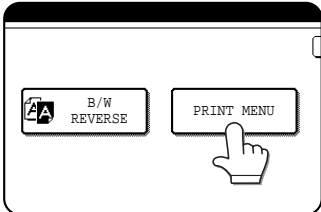

The print menu setting screen will appear. The print menu icon (☰) will also appear in the upper left corner of the screen to indicate that the function is turned on.

2 Select the print position.

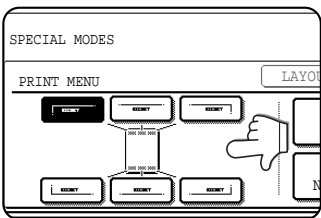

Six positions are available: left, centre, or right of the top or bottom of the page. The touched key is highlighted.

The keys indicating the print position appear as follows depending on the state of the setting:

	Not selected, print menu setting has not been selected.
	Selected during selection of the print menu setting.
	Not selected, print menu setting has already been selected.

The image displayed within each key varies depending on the key position.

3 Select the print menu.

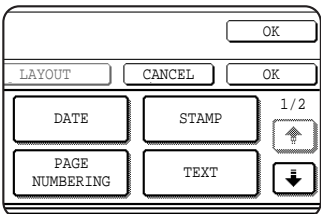

The settings screen of the print menu appears. For information on each of the print menus, see the settings of each.

- DATE (page 5-32) ● STAMP (page 5-33)
- PAGE NUMBERING (page 5-34)
- TEXT (page 5-38)

4 To select print menu settings at another print position, repeat steps 2 and 3.

NOTES

- If the [DATE], [PAGE NUMBERING], or [TEXT] key is touched when other than a "STAMP" print menu setting has been selected for the print position selected in step 2, a message will appear. To overwrite the previously set print content of the print menu that you touched, touch the [YES] key. To keep the previous settings, touch the [NO] key.
- The "DATE" and "PAGE NUMBERING" cannot be set in multiple positions. If either of these keys is touched when a date or page numbering setting has already been configured, a message will appear asking you if you wish to move the print settings to the position that you selected in step 2. To move the print settings, touch the [YES] key. Otherwise touch the [NO] key.

5 Touch the [DOWN] key.

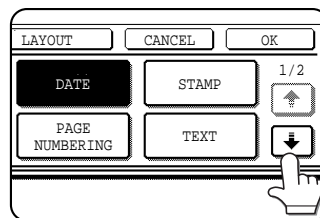

6 To specify the orientation of the original, touch the [ORIGINAL ORIENTATION] key.

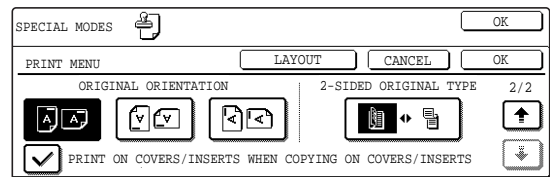

If you placed a two-sided original, touch the [ORIGINAL ORIENTATION] key to specify the binding style (book or tablet). The icon of the selected binding style is highlighted.

7 If you are adding covers or inserts, select whether or not you wish to print on the covers or inserts.

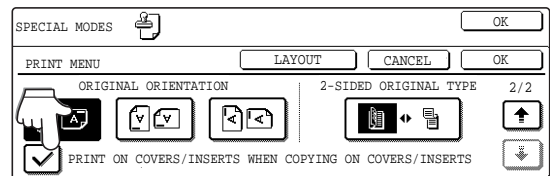

If you do not wish to print on covers or inserts, touch the checkbox to remove the checkmark.

NOTES

- If you are not copying on covers or inserts, printing will not take place on these even if a checkmark appears.
- A page number is never printed on covers or inserts, regardless of the above setting.
- If covers/inserts have been disabled in the key operator programs, the checkbox will be greyed out to prevent selection.

8 Check the print layout if needed (page 5-40).

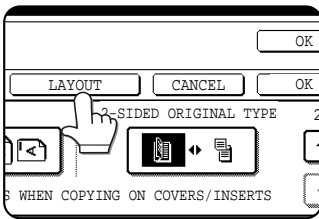

To display the layout and print content of the configured print menu, touch the [LAYOUT] key. The position can be changed and settings cancelled if needed.

NOTE

To cancel print menu...

Touch the [CANCEL] key in the screen of step 3.

9 Touch the [OK] key on the print menu setting screen.

10 Touch the [OK] key on the special modes screen.

About the steps that follow

If an automatic document feeder is being used, see pages 4-7 through 4-10.

If the document glass is being used, see pages 4-11 through 4-13.

Printing in combination with other special functions

When a print menu is combined with one of the following special modes, printing will reflect the selected special mode.

Special modes	Printing operation
Margin shift	Like the copy image, the printed contents are shifted in accordance with the set margin.
Dual page copy	The print content is printed on each copy sheet.
Pamphlet copy Book copy	The print content is printed on each page of the "book".
Multi shot Card shot	The print content is printed on each copy sheet.
Covers/inserts	Whether it prints on the cover pages or the inserted pages needs to select in the print menu.

NOTE

When combined with "Erase", "Job build", "Mirror image" or "B/W reverse", printing takes place normally at the set position on the paper.

■ Printing the date on copies

The date can be printed on copies. Four selections each are available for the date format and the character that separates the year, month, and day.

NOTE

The date must be previously set in the custom settings. (See page 2-13.)

1 Follow steps 1 and 2 of "Common operation procedure for using the print menu" (page 5-30).

2 Touch the [DATE] key.

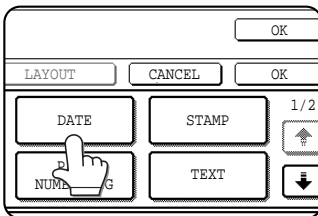

3 Select the date format.

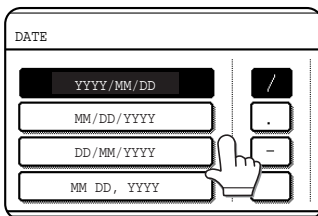

The selected date format is highlighted.

If you selected [YYYY/MM/DD], [MM/DD/YYYY], or [DD/MM/YYYY], you can select the character that separates the year, month, and date. Select [/] (slash), [.] (period), [-] (hyphen), or [] (space).

Select [/] (slash), [.] (period), [-] (hyphen), or [] (space).

4 Check the date and format.

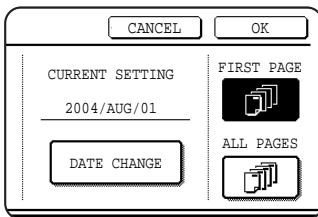

The date to be printed is displayed in "CURRENT SETTING" in the selected format.

The date that appears is the date set in the machine. If you need to

change the date, touch the [DATE CHANGE] key. The following screen appears.

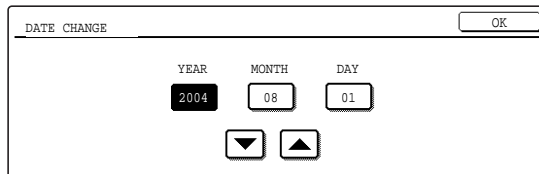

Touch the key of the number (year, month, or day) that needs to be changed, and then adjust the number with the ▼ or ▲ key. When finished, touch the [OK] key.

NOTE

If you select a non-existent date (for example, Feb. 30), the [OK] key will grey out to prevent entry of the date.

5 Select the pages to be printed on.

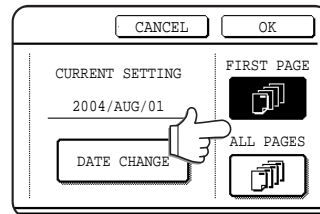

Select whether to print on only the first page, or all pages. The touched key is highlighted.

6 Touch the [OK] key.

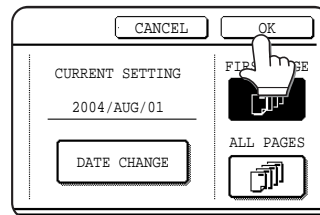

7 Continue from step 4 of "Common operation procedure for using the print menu" (page 5-30).

NOTE

To cancel a date print setting...

Touch the [CANCEL] key in the date selection screen. (The screen of step 6.)

■ Printing a stamp (reverse text) on copies

A message such as "CONFIDENTIAL" can be printed in reverse text on copies. The following 12 messages are available.

CONFIDENTIAL	PRIORITY	PRELIMINARY	FINAL
FOR YOUR INFO.	DO NOT COPY	IMPORTANT	COPY
URGENT	DRAFT	TOP SECRET	PLEASE REPLY

You can select from three density levels for the background of the stamp. Two selections are available for the size of the stamp.

NOTE
The text of the stamp cannot be edited.

1 Follow steps 1 and 2 of "Common operation procedure for using the print menu" (page 5-30).

2 Touch the [STAMP] key.

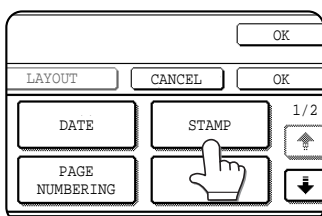

3 Select the stamp that you wish to print.

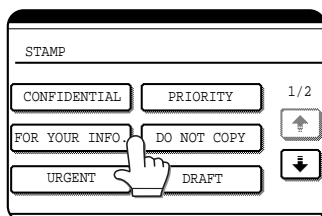

The selected stamp is highlighted. If the desired stamp does not appear, change screens with the or key.

4 Adjust the exposure as needed.

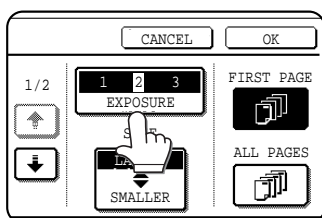

The density of the background of the stamp can be adjusted. Touch the [EXPOSURE] key to display the following screen.

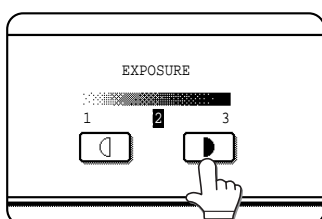

Touch the key for a darker background. Touch the key for a lighter background (3 levels). When finished, touch the [OK] key.

5 Select the desired stamp size.

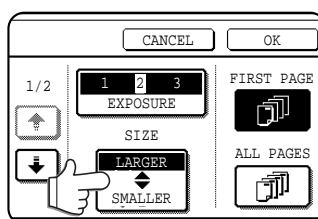

"LARGER" is initially selected. To make the stamp smaller, touch the key. "Smaller" is selected when [SMALLER] is highlighted.

6 Select the pages to be printed on.

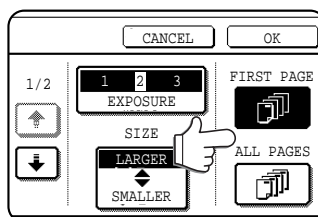

Select whether to print on only the first page, or all pages. The touched key is highlighted.

7 Touch the [OK] key.

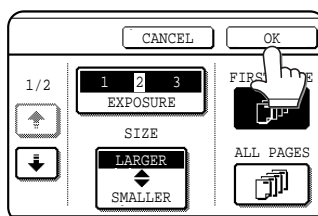

8 Continue from step 4 of "Common operation procedure for using the print menu" (page 5-30).

NOTE
To cancel a stamp setting... Touch the [CANCEL] key in the stamp selection screen. (The screen of step 7.)

■ Printing the page number on copies

The page number can be printed on copies. One of 6 formats can be selected for the page number.

1 Follow steps 1 and 2 of "Common operation procedure for using the print menu" (page 5-30).

2 Touch the [PAGE NUMBERING] key.

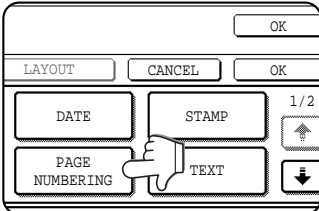

3 Select the page number format.

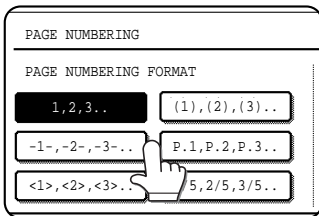

The selected format is highlighted.

If you selected "1/5, 2/5, 3/5",

"PAGE NUMBER/TOTAL PAGES" will be printed. "AUTO" is initially selected for "TOTAL PAGE", which means that the number of scanned original pages is automatically used. If you need to enter the total pages manually (for example, when a large number of originals are scanned in batches), touch the [MANUAL] key to display the total page entry screen.

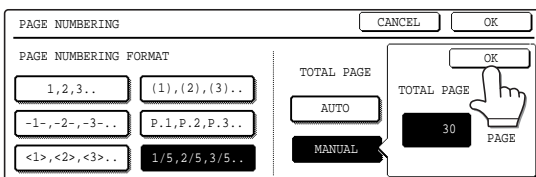

Enter the total pages (1 to 999) with the numeric keys and touch the [OK] key.

NOTES

- When two-sided copying is performed, each side of the paper is counted as a page. If the last page is blank, it will not be included in the total pages. However, if [COUNT BACK COVER] is selected, the last page will be counted. (See step 7.)
- When used in combination with "Dual page copy", "Multi shot", or "Card shot", the number of copied images is the total pages.
- When used in combination with "Pamphlet copy" or "Book copy", the number of pages in the "book" is the total pages.

4 If you need to change the starting or ending number of page numbering, the first page printed on, or the print settings for covers/inserts, touch the [PAGE NUMBER] key.

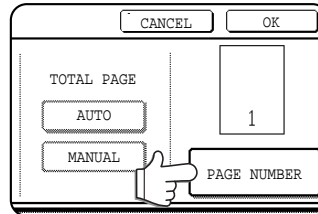

5 Touch the [MANUAL] key.

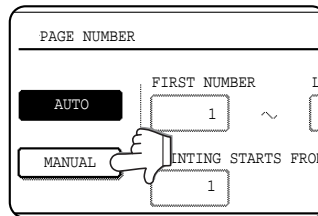

6 Enter settings for "FIRST NUMBER", "LAST NUMBER", and "PRINTING STARTS FROM SHEET".

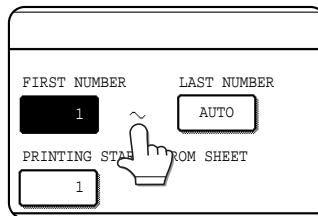

Touch each key so that it is highlighted, and then enter the number with the numeric keys (1 to 999).

To return a number to its initial value (FIRST

NUMBER: 1, LAST NUMBER: AUTO, PRINTING STARTS FROM SHEET: 1), press the [C] (clear) key while the key of the number is highlighted. If you enter the wrong number, press the [C] (clear) key and enter the correct number.

NOTES

- A last number smaller than the "FIRST NUMBER" number cannot be set.
- "LAST NUMBER" is initially set to "AUTO", which means that the page number is printed on each page through the final page in accordance with the "FIRST NUMBER" and "PRINTING STARTS FROM SHEET" settings.
- A number less than the total page number is set as the last number, the page number will not be printed on the pages that follow the set number.
- Unlike the first and last page numbers, "PRINTING STARTS FROM SHEET" specifies the sheet of paper (not the page number) from which printing of the page number begins. For example, when "3" is selected for one-sided copying, printing of the page number will start from the 3rd sheet of copy paper (the copy of the 3rd original page). When "3" is selected for two-sided copying, printing of the page number will start from the 3rd sheet of copy paper, which is the copy of the 5th original page.

7 When covers/inserts are added and you wish to include the covers/inserts in the page number count, touch the [COVERS/INSERTS COUNTING] key.

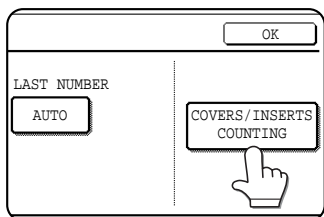

8 Select the checkboxes of the items that you wish to include in the page number count and then touch the [OK] key.

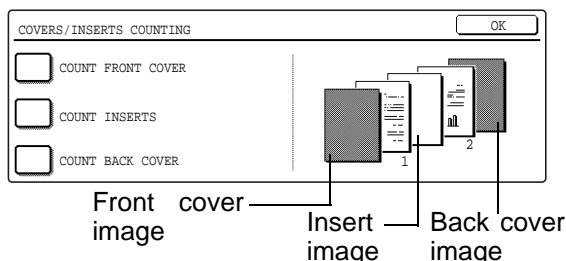

Items that are selected are reflected in the print image on the right side of the screen.

NOTES

- When an item is selected, one inserted sheet (front cover, insert, or back cover) is counted as one page during one-sided copying, and two pages during two-sided copying. However, if one-sided copying is used for the body pages and two-sided copying is used for the inserted sheets, each body page will be counted as one page and each inserted sheet will be counted as two pages.
- Printing never takes place on the front cover and back cover, regardless of whether or not these are counted.
- To print on an insert, the insert must be counted and it must be copied on.

9 Touch the [OK] key.

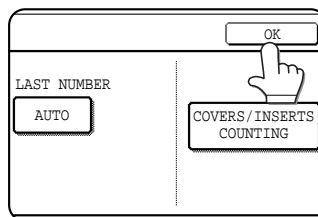

10 Touch the [OK] key.

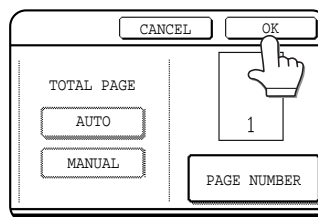

11 Continue from step 4 of "Common operation procedure for using the print menu" (page 5-30).

NOTE
To cancel a page number setting...
 Touch the [CANCEL] key in the page number selection screen. (The screen of step 10.)

NOTES

- Copying in group mode is not possible when page number printing is selected. The mode will automatically switch to sort mode.
- When the page number print position is set to the left or right side and "Pamphlet copy" or "Book copy" is selected, the position of the page numbers will alternate so that they are always on the outside when the pamphlet/book is opened. If a stamp is set in an area with a page numbering setting, the position of the stamp will alternate in the same way.

If another item is set in a position that changes, that item will appear in the position that alternates with the page number position.
 Print menus not related to the alternating print positions will appear in their set positions.
 [Example] When the page number format "1, 2, 3.." is selected when performing pamphlet copying of 4 pages, the copies will appear as shown below.
 In this example, the page number is at the bottom of the page and the date is at the top, so the position of the date does not change.

Print settings	Front		Back	
Date	2004/AUG/1	2004/AUG/1	2004/AUG/1	2004/AUG/1
Stamp	CONFIDENTIAL	CONFIDENTIAL	CONFIDENTIAL	CONFIDENTIAL
Page numbering Text	4 Minutes of meeting	Minutes of meeting 1	2 Minutes of meeting	Minutes of meeting 3

Examples of page number printing

Page number printing during one-sided copying (5 originals)

Setting	Value	1st page	2nd page	3rd page	4th page	5th page
TOTAL PAGE	AUTO	<div style="border: 1px solid black; padding: 5px; text-align: center;"> A 1/5 </div>	<div style="border: 1px solid black; padding: 5px; text-align: center;"> B 2/5 </div>	<div style="border: 1px solid black; padding: 5px; text-align: center;"> C 3/5 </div>	<div style="border: 1px solid black; padding: 5px; text-align: center;"> D 4/5 </div>	<div style="border: 1px solid black; padding: 5px; text-align: center;"> E 5/5 </div>
FIRST NUMBER	1					
LAST NUMBER	AUTO					
PRINTING STARTS FROM SHEET	1					
Printed contents when settings are changed as follows	FIRST NUMBER: 11	11/15	12/15	13/15	14/15	15/15
	FIRST NUMBER: 11 LAST NUMBER: 13	11/13	12/13	13/13	Not printed	Not printed
	TOTAL PAGE: 2	1/2	2/2	Not printed	Not printed	Not printed
	TOTAL PAGE: 15 FIRST NUMBER: 11 LAST NUMBER: 13	11/15	12/15	13/15	Not printed	Not printed
	PRINTING STARTS FROM SHEET: 3	Not printed	Not printed	1/3	2/3	3/3

Page number printing during two-sided copying (9 originals)

Setting	Value	1st page		2nd page		3rd page		4th page		5th page	
		Front	Back	Front	Back	Front	Back	Front	Back	Front	Back
TOTAL PAGE	AUTO	<div style="border: 1px solid black; padding: 5px; text-align: center;"> A 1/9 </div>	<div style="border: 1px solid black; padding: 5px; text-align: center;"> B 2/9 </div>	<div style="border: 1px solid black; padding: 5px; text-align: center;"> C 3/9 </div>	<div style="border: 1px solid black; padding: 5px; text-align: center;"> D 4/9 </div>	<div style="border: 1px solid black; padding: 5px; text-align: center;"> E 5/9 </div>	<div style="border: 1px solid black; padding: 5px; text-align: center;"> F 6/9 </div>	<div style="border: 1px solid black; padding: 5px; text-align: center;"> G 7/9 </div>	<div style="border: 1px solid black; padding: 5px; text-align: center;"> H 8/9 </div>	<div style="border: 1px solid black; padding: 5px; text-align: center;"> I 9/9 </div>	<div style="border: 1px solid black; padding: 5px; text-align: center;"> [] </div>
FIRST NUMBER	1										
LAST NUMBER	AUTO										
PRINTING STARTS FROM SHEET	1										
Printed contents when settings are changed as follows	PRINTING STARTS FROM SHEET: 3	Not printed	Not printed	Not printed	Not printed	1/5	2/5	3/5	4/5	5/5	Not printed

Page number printing during one-sided copying of body pages with covers inserted (4 originals)

Setting	Value	1st page (Front cover)	2nd page	3rd page	4th page	5th page
TOTAL PAGE	AUTO	<div style="border: 1px solid black; padding: 5px; text-align: center;"> [] </div>	<div style="border: 1px solid black; padding: 5px; text-align: center;"> A 1/4 </div>	<div style="border: 1px solid black; padding: 5px; text-align: center;"> B 2/4 </div>	<div style="border: 1px solid black; padding: 5px; text-align: center;"> C 3/4 </div>	<div style="border: 1px solid black; padding: 5px; text-align: center;"> D 4/4 </div>
FIRST NUMBER	1					
LAST NUMBER	AUTO					
PRINTING STARTS FROM SHEET	1					
COUNT FRONT COVER	Not selected					
Printed contents when settings are changed as follows	PRINTING STARTS FROM SHEET: 2	Not printed	Not printed	1/3	2/3	3/3
	COUNT FRONT COVER: Selected	Not printed (count)	2/5	3/5	4/5	5/5
	COUNT FRONT COVER: Selected PRINTING STARTS FROM SHEET: 2	Not printed (count)	1/4	2/4	3/4	4/4

When a back cover is inserted, page numbers are counted and printed in the same way. Note that page numbers are never printed on front and back covers.

Page number printing during two-sided copying of body pages with covers (one-side copying) inserted (9 originals)

Setting	Value	1st page (front cover)		2nd page		3rd page		4th page		5th page	
		Front	Back	Front	Back	Front	Back	Front	Back	Front	Back
TOTAL PAGE	AUTO										
FIRST NUMBER	1										
LAST NUMBER	AUTO										
PRINTING STARTS FROM SHEET	1	A		B 1/8	C 2/8	D 3/8	E 4/8	F 5/8	G 6/8	H 7/8	I 8/8
COUNT FRONT COVER	Not selected										
Printed contents when settings are changed as follows	PRINTING STARTS FROM SHEET: 3	Not printed	Not printed	Not printed	Not printed	Not printed	Not printed	1/4	2/4	3/4	4/4
	COUNT FRONT COVER: Selected	Not printed (count)	Not printed (count)	3/10	4/10	5/10	6/10	7/10	8/10	9/10	10/10
	COUNT FRONT COVER: Selected PRINTING STARTS FROM SHEET: 3	Not printed (count)	Not printed (count)	Not printed	Not printed	1/6	2/6	3/6	4/6	5/6	6/6

When a back cover is inserted, page numbers are counted and printed in the same way. Note that page numbers are never printed on front and back covers.

Page number printing during one-sided copying with inserts (4 originals; 5 originals when copying on inserts)

Setting	Value	1st page	2nd page	3rd page (insert)	4th page	5th page
TOTAL PAGE	AUTO					
FIRST NUMBER	1					
LAST NUMBER	AUTO					
PRINTING STARTS FROM SHEET	1	A 1/4	B 2/4	C	D 3/4	E 4/4
COUNT INSERTS	Not selected					
Printed contents when copying on inserts and settings are changed as follows	PRINTING STARTS FROM SHEET: 3	Not printed	Not printed	Not printed	1/2	2/2
	COUNT INSERTS: Selected	1/5	2/5	3/5 (count)	4/5	5/5
	COUNT INSERTS: Selected PRINTING STARTS FROM SHEET: 3	Not printed	Not printed	1/3 (count)	2/3	3/3
Printed contents when not copying on inserts and settings are changed as follows	COUNT INSERTS: Selected	1/5	2/5	Not printed (count)	4/5	5/5
	COUNT INSERTS: Selected PRINTING STARTS FROM SHEET: 3	Not printed	Not printed	Not printed (count)	2/3	3/3

When inserts are not copied on, the page number is not printed.

Page number printing during two-sided copying of body pages with inserts (one-side copying) (9 originals)

Setting	Value	1st page		2nd page		3rd page (insert)		4th page		5th page	
		Front	Back	Front	Back	Front	Back	Front	Back	Front	Back
TOTAL PAGE	AUTO										
FIRST NUMBER	1										
LAST NUMBER	AUTO										
PRINTING STARTS FROM SHEET	1	A 1/8	B 2/8	C 3/8	D 4/8	E		F 5/8	G 6/8	H 7/8	I 8/8
COUNT INSERTS	Not selected										
Printed contents when settings are changed as follows	COUNT INSERTS: Selected	1/10	2/10	3/10	4/10	5/10	Not printed (count)	7/10	8/10	9/10	10/10

■ **Printing entered text on copies**

Entered text can be printed on copies. Up to 50 characters can be printed.

Up to 30 sequences of frequently used text can be stored. See "Storing text sequences" (page 5-39).

NOTE
When the machine is connected to a network, the printed text sequences can be stored and deleted in the Web page. For details, see Help in the Web page.

1 Follow steps 1 and 2 of "Common operation procedure for using the print menu" (page 5-30).

2 Touch the [TEXT] key.

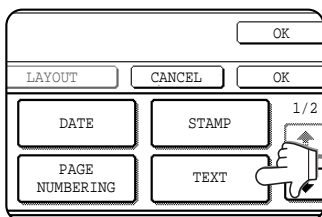

3 If you wish to use one of the preset text sequences, touch the [RECALL] key. To directly enter the text, touch the [DIRECT ENTRY] key.

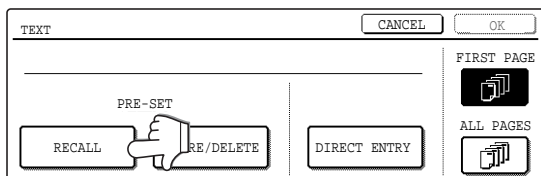

If you touch the [DIRECT ENTRY] key, a character entry screen will appear. For information on entering characters, see page 7-26. When finished, click the [OK] key to close the character entry screen. (Go to step 6.)

4 The stored text sequences will appear as keys. Touch the key of the desired text sequence.

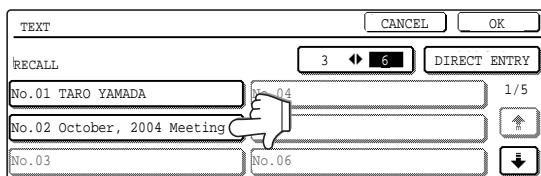

The selected text sequence key is highlighted. If the desired text sequence key does not appear, change screens with the [↑] or [↓] key. The display is initially set to show 6 keys per screen. This can be changed to 3 keys per screen by touching the [3 ◀▶ 6] key. When 3 keys are displayed, the entire text sequence will appear in each key. (When 6 keys are displayed, up to 22 characters appear in each key.)

5 Touch the [OK] key.

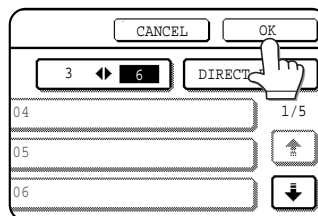

To edit the selected text sequence, touch the [DIRECT ENTRY] key to display the character entry screen. The selected text sequence is entered.

For information on entering characters, see page 7-26. When finished, touch the [OK] key to close the character entry screen.

6 Select the pages to be printed on.

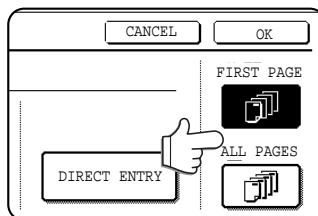

Select whether to print on only the first page, or all pages. The touched key is highlighted.

7 Touch the [OK] key.

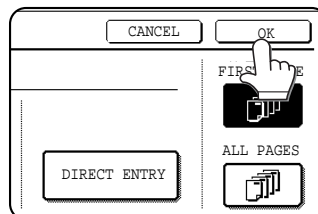

8 Continue from step 4 of "Common operation procedure for using the print menu" (page 5-30).

NOTE
To cancel a text setting...
Touch the [CANCEL] key in the text print screen. (The screen of step 7.)

Storing text sequences

1 Follow steps 1 and 2 of "Common operation procedure for using the print menu" (page 5-30).

2 Touch the [TEXT] key.

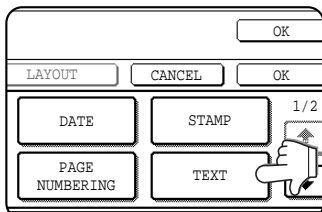

3 Touch the [STORE/DELETE] key.

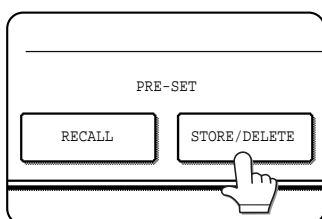

4 Touch a key that has not been programmed (a key in which No. xx appears).

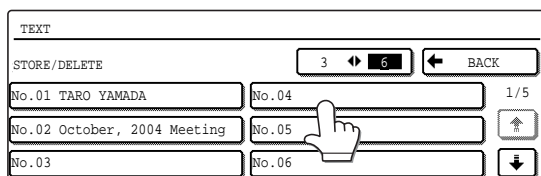

When touched, the character entry screen appears. Enter the text (max. 50 characters). For information on entering characters, see page 7-26. When finished, touch the [OK] key to close the character entry screen.

If no free keys appear, change screens with the or key.

5 Touch the [BACK] key.

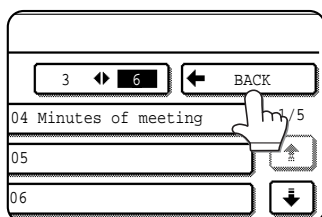

The entered text is stored.

Editing and deleting stored text

1 Follow steps 1 and 2 of "Common operation procedure for using the print menu" (page 5-30).

2 Touch the [TEXT] key.

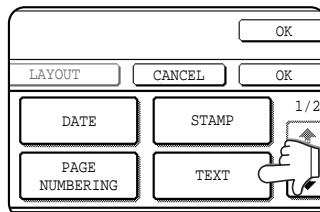

3 Touch the [STORE/DELETE] key.

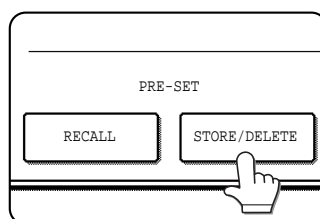

4 Touch the text key that you wish to edit or delete.

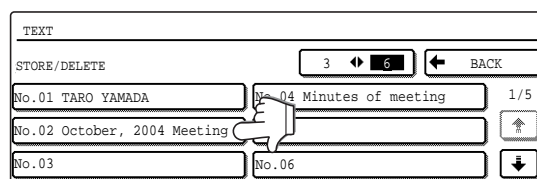

5 To edit the text, touch the [AMEND] key. To delete the text, touch the [DELETE] key.

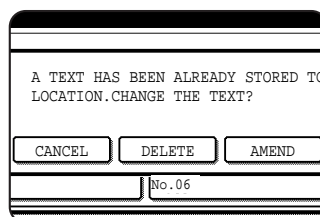

When the [AMEND] key is touched, the character entry screen appears. The selected text sequence is entered. For information on entering characters, see page 7-

26. When finished, touch the [OK] key to close the character entry screen.

If you touch the [DELETE] key, the text will be deleted and you will return to the screen of step 4.

To cancel editing or deletion, touch the [CANCEL] key.

6 Touch the [BACK] key.

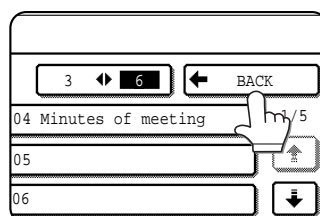

■ Checking and changing the print layout

You can check the print layout after the print items have been selected. If needed you can change the print position or delete print content.

1 Touch the [LAYOUT] key on the print menu screen.

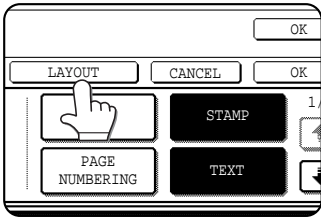

2 Touch the key in which you wish to change the print position or delete print content.

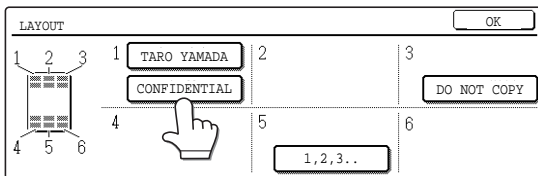

NOTE
Up to 14 characters of the print text appears in the key.

3 To change the print position, touch the [MOVE] key. To delete print content, touch the [DELETE] key.

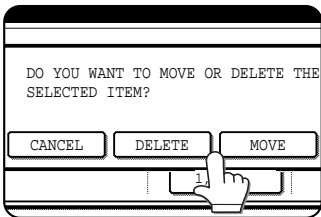

If you touched the [MOVE] key, the new position selection screen appears.
If you touched the [DELETE] key, the print content is deleted. (Go to step 6.)

4 Touch the key of the new position.

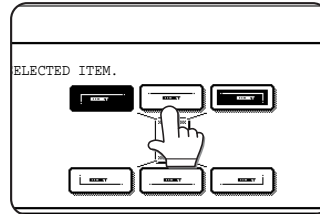

The selected key is highlighted and the print position changes to the new position.

The keys indicating the print position appear as follows depending on the state of the setting:

	Print position without any set print menus.
	Currently set print position.
	Print position with another competing print menu set. (When moving a stamp, this indicates that another stamp has been set. When moving a print menu other than a stamp, this indicates that the date, page number, or text has been set.)

NOTE
If you wish to swap the contents of two positions, temporarily move the content of one position to an unused position and then complete the swap.

5 Touch the [OK] key.

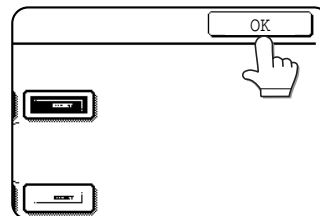

If you attempt to move print content to a position that already has print content set, a message will appear asking you if you wish to overwrite the previously set content.

To overwrite the content, touch the [YES] key. To cancel the move and return to the condition before the [OK] key was touched, touch the [NO] key.

6 Touch the [OK] key.

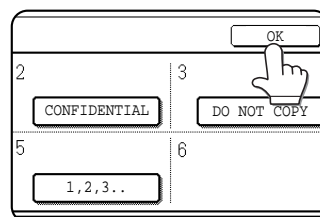

STORING, USING AND DELETING JOB PROGRAMS

The steps of up to 10 copy jobs can be stored as job programs. Job programs can be called up with ease, and are retained even when the power is turned off. By storing frequently used copy settings in a job program, you can eliminate the bother of selecting the settings each time you use them for a copy job.

- If any settings related to the steps of a job program are changed in the key operator programs after the job program is stored, the steps related to the changed settings will not be included when the job program is called up.
- To exit the job programs mode, press the [CA] (clear all) key on the operation panel or touch the [EXIT] key on the touch panel.

Storing a job program

1 Press the [#]/P key.

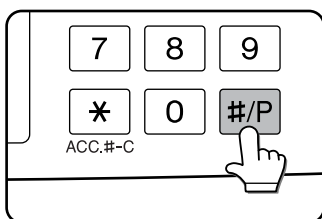

2 Touch the [STORE/DELETE] key.

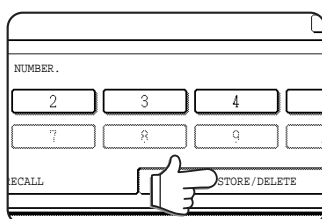

3 Touch the number key ([1] to [10]) in which you wish to stored the job program.

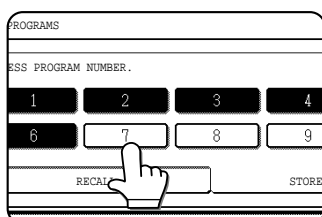

Number keys in which job programs are already stored are highlighted.

4 Select the copy settings that you wish to store in the job program.

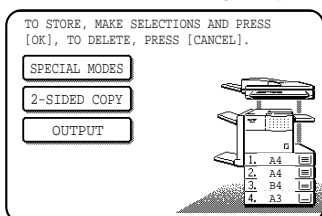

The number of copies cannot be stored.

5 Touch the [OK] key.

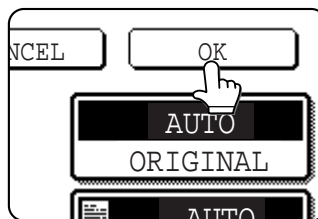

The selected settings will be stored in the number key selected in step 3.

■ If a number key is selected in step 3 that has already been programmed.

A setting confirmation screen will appear. To replace the existing program with the new program, touch the [STORE] key and continue from step 4. If you do not wish to replace the existing program, touch the [CANCEL] key to return to the screen of step 3 and select a different number key.

NOTE

If overwriting of programmed copy settings has been prohibited in the key operator programs, you will not be able to store a job program. (See page 15 of the key operator's guide.)

5

Calling up a job program

1 Press the [# / P] key.

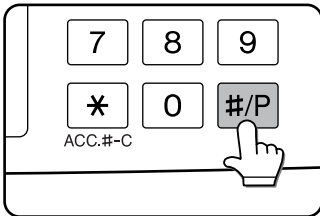

2 Touch the number key of the desired job program.

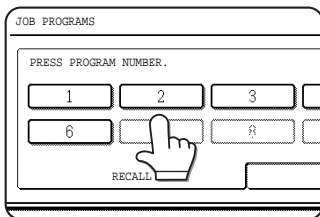

The screen automatically closes and the job program is called up. A number key that does not have a job program cannot be selected.

3 Set the number of copies if needed and then press the [START] key.

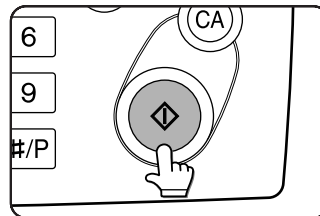

Copying will begin using the settings of the job program.

Deleting a stored job program

1 Press the [# / P] key.

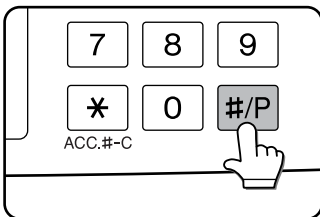

2 Touch the [STORE / DELETE] key.

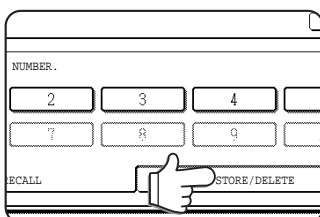

3 Select a storage register number of the program to be deleted.

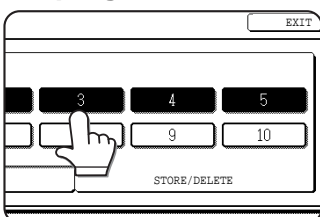

If a number key for which no job program has been stored is selected, the screen will change to the screen of step 4 on the previous page (for storing a job program).

4 Touch the [DELETE] key.

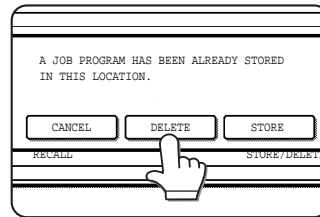

The selected program is deleted and you return to the screen of step 3. To return to the screen of step 3 without deleting the job program, touch the [CANCEL] key. In both cases, touch the [EXIT] key on the screen displayed in the screen of step 3 to exit the job program mode.

NOTE

If overwriting of programmed copy settings has been prohibited in the key operator programs, you will not be able to clear a job program. (See page 15 of the key operator's guide.)

INTERRUPTING A COPY RUN

The copy of the original scanned in interrupt mode is output before the remainder of the interrupted copy job.

1 Touch the [INTERRUPT] key.

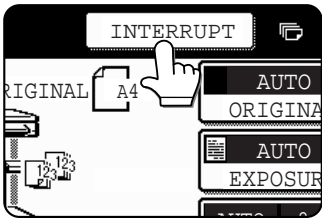

If interrupt copying is possible during a copy run, the [INTERRUPT] key will appear. (If the key does not appear, interrupt copying is not possible.)

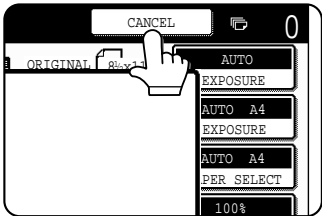

When the [INTERRUPT] key is touched in step 1, the [INTERRUPT] key will be replaced by the [CANCEL] key as shown in the illustration.

To cancel an interrupt copy job while the interrupt original is being scanned or while you are selecting copy settings, touch the [CANCEL] key.

NOTES

- If you touch the [INTERRUPT] key when auditing mode is enabled, the display will prompt you to enter your account number. Enter your account number with the numeric keys. The copies you make will be added to the count of the entered account number.
- If a copy is being printed when the [INTERRUPT] key is pressed, interrupt mode will begin after the copy is finished.
- If the document glass is used for an interrupt copy job, two-sided copying, sort copying, and staple sort copying cannot be selected. If any of these functions are necessary, use the document feeder.

2 Place the original for the interrupt copy job in the document feeder or on the document glass (page 4-3).

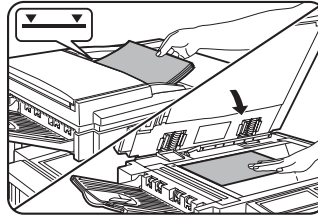

3 Select the exposure mode, paper size, number of copies, and any other copy settings as needed, and then press the [START] key.

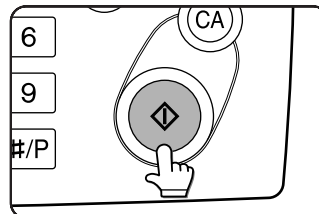

4 The previous copy job automatically resumes after the interrupt job finishes.

5



CHAPTER 6

MACHINE MAINTENANCE (FOR COPYING)

This chapter explains procedures for cleaning the machine, and troubleshooting.

	Page
USER MAINTENANCE	6-2
• Cleaning the document glass and the automatic document feeder	6-2
• Cleaning the main charger of the photoconductive drum.....	6-2
TROUBLESHOOTING	6-3

USER MAINTENANCE

Cleaning the document glass and the automatic document feeder

If the document glass, document cover or automatic document scanning unit have dirty spots, these spots will form lines in scanned images. These will show up as defects when the images are printed. Always keep these parts clean.

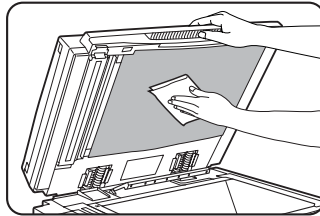
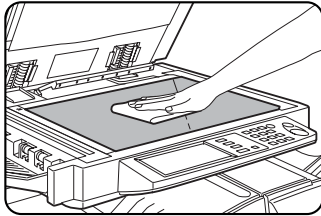

Wipe with a clean, soft cloth. If necessary, moisten the cloth with water or a small amount of neutral detergent. When finished, wipe dry with a clean cloth. When cleaning, do not use thinner, benzene, or similar volatile cleaning agents.

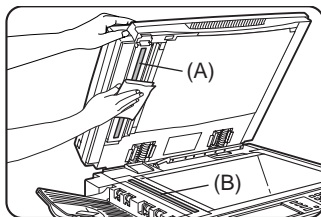

If black or white stripes appear on printed images of originals that were fed through the automatic document feeder, wipe the long narrow glasses in the scanning unit ((A) and (B) in the illustration).

Example of dirty print image

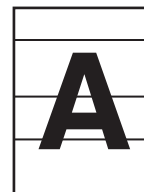

Black stripes



White stripes

CAUTION

Do not use flammable spray to clean the machine. If gas from the spray comes in contact with hot electrical components or the fusing unit inside the machine, fire or electrical shock may result.

Cleaning the main charger of the photoconductive drum

If black (or white) lines appear even after you have cleaned the document glass and document feeder, use the charger cleaner to clean the main charger that charges the drum.

1 Switch off the power switch (see page 1-17).

2 Open the front cover.

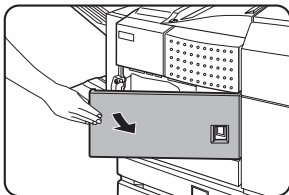

3 Slowly pull out the green knob (charger cleaner).

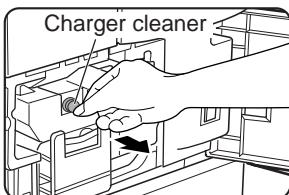

4 Once the knob is pulled out, slowly push it back in.

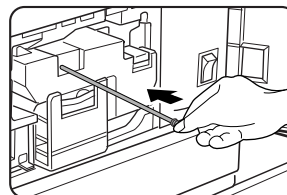

5 Close the front cover and switch on the power switch.

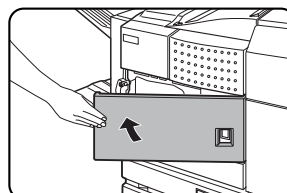

NOTES

- If this does not solve the problem, pull the knob out and push it back in 2 more times.
- When pulling and pushing the knob to clean the charger, pull and push the knob slowly from one end to the other.

TROUBLESHOOTING

Check the following troubleshooting list before requesting service as many problems can be fixed by the user. If you are unable to solve the problem by checking the list, turn off the power switch, and unplug the power cord. Problems related to the copy function are described below. For problems related to general use of the machine, see page 2-23.

Problem	Check	Solution
Machine does not operate.	Is the [START] key indicator off?	This indicates that the machine is warming up (warming up lasts no more than 80 seconds after the power switch is turned on). Copying is not possible during this time. Wait until the [START] key light illuminates.
Copies are too dark or too light.	Is the original image too dark or too light?	Select an appropriate exposure mode for the original being copied and adjust the copy exposure. (See page 4-14.)
	Is the exposure mode set to "AUTO"?	The exposure level for "AUTO" can be adjusted using the "Exposure adjustment" key operator program. Contact your key operator. (See page 14 of the key operator's guide.)
	An appropriate exposure mode for the original has not been selected.	Change the exposure mode to "AUTO" or manually select an appropriate resolution setting. (See page 4-14.)
Text is not clear on a copy.	An appropriate exposure mode for the original has not been selected.	Change the exposure mode to "TEXT". (See page 4-14.)
Smudges appear on copies.	Document glass or document cover dirty?	Clean regularly. (See page 6-2.)
	Black lines appear on copies when the automatic document feeder is used.	Clean the original scanning area. (See page 6-2.)
	Original smudged or blotchy?	Use a clean original.
Image cannot be rotated.	Is the auto paper select or auto image function selected?	Rotation copy functions only if the machine is either in the auto paper select mode or in the auto image mode. (See page 4-15.)
Part of original image is not copied.	Is the original positioned correctly?	Set the original properly. (See page 4-3.)
	Is the copy ratio proper for the original and paper sizes?	Use the auto image function to select the appropriate copy ratio based on the original and copy sizes. (See page 4-15.)
Blank copies	Is the original placed correctly?	When using the document glass, place the original face down. When using the automatic document feeder, place original face down. (See page 4-3.)
Order of copies incorrect	Is the order of originals correct?	When using the document glass, place the originals from the first page one sheet at a time. When using the automatic document feeder, place the originals with the first page down.
Job cancellation needed	Is a message requesting cancellation of job displayed?	Press the [CA] key to cancel the current job.



CHAPTER 7

DOCUMENT FILING FUNCTION

	Page
OVERVIEW.....	7-2
• Document filing function.....	7-2
TO USE THE DOCUMENT FILING FUNCTION.....	7-4
• A look at the operation panel	7-4
• Saving files.....	7-4
• Main screen of document filing	7-5
• Document filing icons	7-5
SAVING A DOCUMENT IMAGE FILE	7-6
• Quick File	7-6
• Filing.....	7-7
• Print jobs	7-9
• Scan Save.....	7-10
CALLING UP AND USING A FILE	7-13
• Searching for and calling up a saved file	7-13
• Calling up and using a saved file	7-15
CUSTOM SETTINGS	7-21
• Creating, editing, and deleting user names and folders.....	7-21
ENTERING CHARACTERS.....	7-26
TROUBLESHOOTING	7-28

OVERVIEW

Document filing function

This function can only be used on the d-Copia 315 Network version, or when the document filling function has been added. The document filing function allows you to save a document image in the machine's hard disk as a data file. The image can be called up and printed or transmitted as needed.

The scanned document image is saved when printing or transmitting a document in copy mode, printer mode, or image send mode ("QUICK FILE" or "FILE"). A document can also be scanned and saved without being printed, copied, or transmitted ("scan save").

To allow you to search for the file and call it up, names (user name, file name, etc.) can be assigned to the file (except when using Quick File in copy mode or fax/image send mode).

■ Data flow

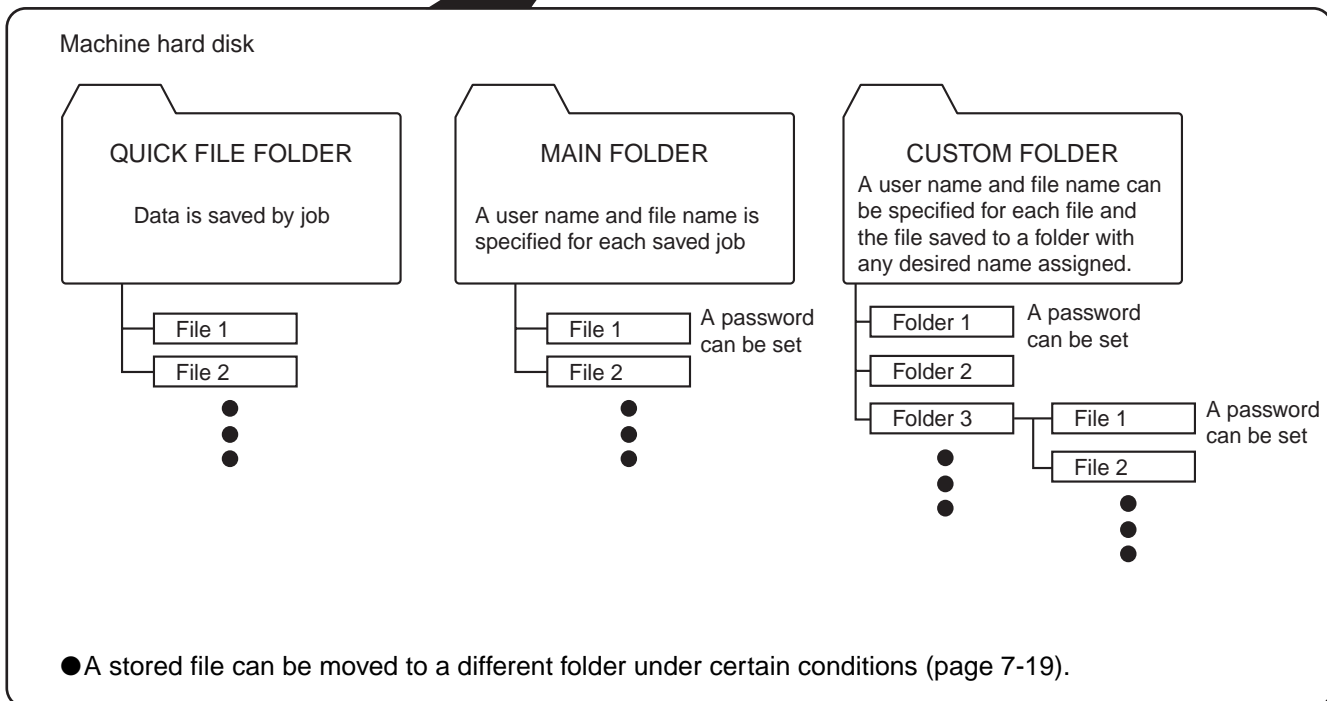
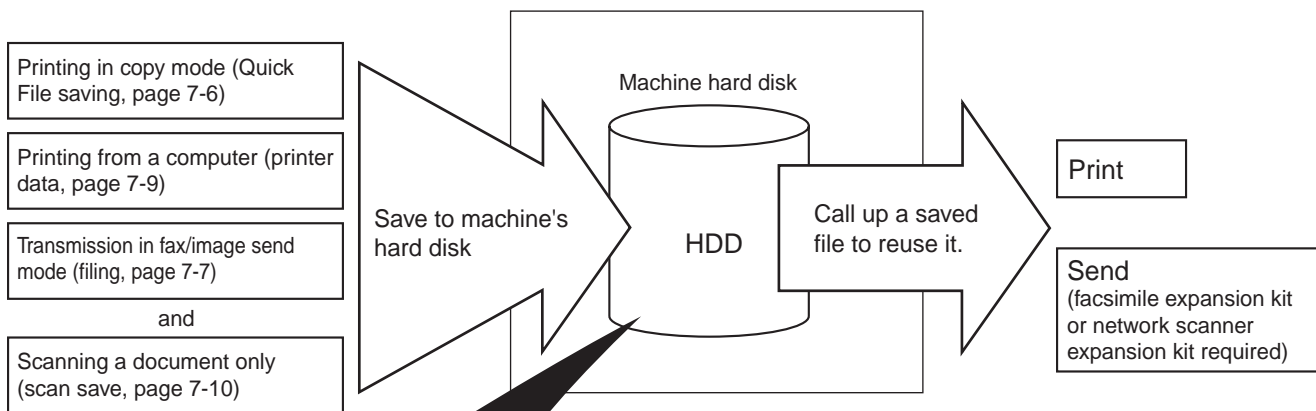

■ Quick File folder

When [QUICK FILE FOLDER] is selected in the main screen of any of the modes, the file is saved in this folder.

Up to 1000 files can be saved in the Quick File folder. All files in the Quick File Folder can be deleted using a key operator program. If you have a file that you do not want deleted, set the file attribute to [PROTECT] (up to 500 files can be protected). (See [Property change] on page 7-18)

The following user and file names are automatically assigned (except when using Quick File in copy mode or fax/image send mode):

User name : User unknown

File name (example) : COPY_10012004_014050PM (job mode and month, day, year, hour, minute, second, AM/PM of save). (In the example, the file was saved on 10/1/2004 at 13:40 and 50 sec in copy mode.)

When saved, jobs are classified by mode. A saved job can be called up from the COMPLETE job status screen.

■ Main folder

When saving a file, a previously stored user name (see [CUSTOM SETTINGS] on page 7-21) can be specified and any file name can be assigned.

A password can also be set for a saved file ([CONFIDENTIAL] save). (See [Property change] on page 7-18.)

If a user name and file name are not selected, a name in the same format as Quick File is automatically assigned.

■ Custom folder

Up to 500 folders (named as desired) can be created in this folder. When saving a file in one of these folders, a previously stored user name (see [CUSTOM SETTINGS] on page 7-21) can be specified and any file name can be assigned.

A password can be set for a file saved in one of these folders.

■ Attributes of saved files

The protect setting can be selected for files saved with the document filing function. This prevents a file from being moved or automatically or manually deleted.

Three attributes are available for saved files: [SHARING], [PROTECT], and [CONFIDENTIAL]. When saved with the [SHARING] attribute, a file is not protected. When saved with the [PROTECT] or [CONFIDENTIAL] attribute, a file is protected.

Files saved to the Quick File folder are all [SHARING]. When saving a file to the main folder or a custom folder, [SHARING] or [CONFIDENTIAL] can be selected.

- A [SHARING] file can be changed to a [PROTECT] or [CONFIDENTIAL] file using [Property change] (page 7-18).
- A password is set for a [CONFIDENTIAL] file to protect it. (The password must be entered to call up the file.)
- A password cannot be set for a [PROTECT] file, however, as long as the file is not changed to [SHARING] with [PROPERTY CHANGE], the file will be protected.

CAUTION

- Documents saved with [QUICK FILE] are shared files that can be called up by anyone and printed or transmitted. For this reason, do not use Quick File for sensitive documents or documents that you do not want to be reused by others.
- When saving a document with [FILE], set the attribute to [CONFIDENTIAL] and set a password to prevent others from reusing the document.
- Even when a file is saved with the [CONFIDENTIAL] attribute, the attribute can be changed afterward to [SHARING] using [Property change] (page 7-18). For this reason, do not save sensitive documents or documents that you do not want to be reused by others.
- Except in cases provided for by law, Olivetti S.p.A. bears no responsibility for any damages that result from the leaking of sensitive information due to 1) manipulation by a third party of any data saved using the Quick File function or filing function, or 2) incorrect operation of the Quick File function or filing function by the operator that saves the data.

TO USE THE DOCUMENT FILING FUNCTION

A look at the operation panel

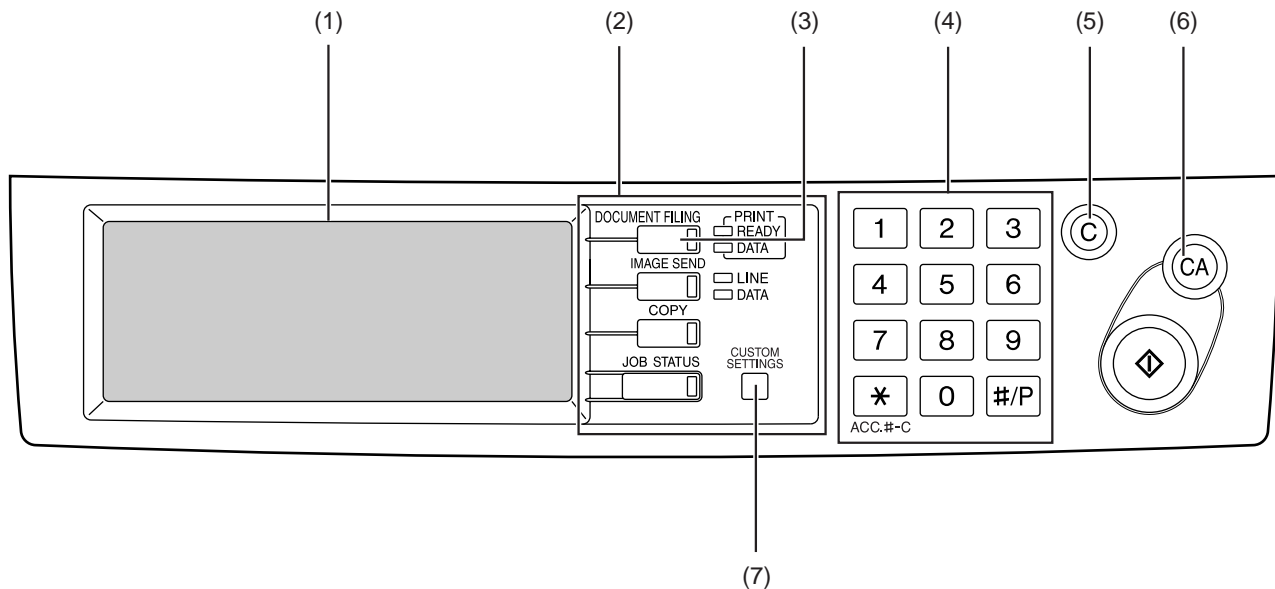

(1) Touch panel (see the next page)

This displays messages and keys. Keys can be touched to select and enter settings.

When a key is touched, a beep will sound and the key will be highlighted to indicate that it is selected.

When a key cannot be selected in a screen, it will be greyed out. If touched, a warning beep will sound to alert you that it cannot be selected.

(2) Mode select keys

Use this key to select the mode.

(3) [DOCUMENT FILING] key

Touch this key to display the main screen of document filing mode.

(4) Numeric keys

Use these keys to enter a password or a numeric value for a setting.

(5) [C] key (clear key)

Use this key if you make a mistake when entering a password or numeric setting.

This key is also used to cancel scanning of a document.

(6) [CA] key (Clear all key)

Use this key to cancel a setting procedure and return to the main screen. The key is also used to cancel a special function.

(7) [CUSTOM SETTINGS] key

Use this key to store, edit or delete a user name or custom folder.

Saving files

To save files to the main folder or custom folders, a user name must be previously stored. To create a folder in the custom folder, the folder name must be stored. These settings are configured in the custom settings.

Follow the procedures explained in "Programming a user name", "Editing and deleting a user name", "Creating a custom folder", and "Editing/deleting a custom folder" on pages 7-22 to 7-25.

Main screen of document filing

To display the main screen of document filing, press the [DOCUMENT FILING] key when the touch panel shows the copy mode screen, image send mode, or the job status screen.

The main screen shows messages, keys, and items that can be selected for document filing.

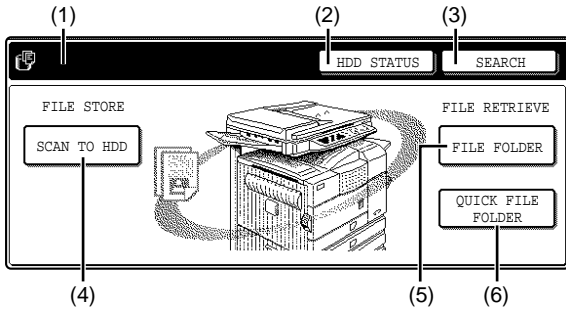

- (1) **Message display**
Displays messages.
- (2) **[HDD STATUS] key**
Touch to check the use of the machine's hard disk.
- (3) **[SEARCH] key**
Touch to search for a file by user name, file name, or folder name.
- (4) **[SCAN TO HDD] key**
Touch to select scan save. Scan save is used to save the image file of a scanned document in the main folder or a custom folder without printing or transmitting the document.
- (5) **[FILE FOLDER] key**
Touch to call up a file from the main folder or the custom folder. When the key is touched, the files in the main folder or the folders in the custom folder appear.
- (6) **[QUICK FILE FOLDER] key**
Touch to call up a file from the Quick File folder. When the key is touched, the files in the Quick File folder appear.

Document filing icons

Main icon	Icon of confidential file or folder	Icon of protected file	Meaning
			Folder
			Copy job file
			Print job file (including direct print jobs)
			Fax transmission job file
			PC-FAX transmission job file
			Internet fax transmission job file
			PC-Internet fax transmission job file
			Scan save file
			E-mail transmission job file
			FTP transmission job file
			Desktop transmission job file

The following icons may appear added to a main icon or alone.

Icon	Meaning
	Confidential file or folder
	Protected file

NOTE

When the file of a job that was saved using scan save is printed in job settings, the icon of the job is highlighted.

SAVING A DOCUMENT IMAGE FILE

Quick File

When printing or transmitting a document in copy mode, printer mode, or fax/image transmission mode, "QUICK FILE" can be selected to save an image of the document to the Quick File folder.

The image can be called up at a later time, allowing you to print or transmit the document without having to locate the original.

NOTE

As an example, the procedure for saving a document to the Quick File folder while copying using the automatic document feeder is explained below.

- 1 Place the originals in the document feeder tray and select resolution and exposure settings.**

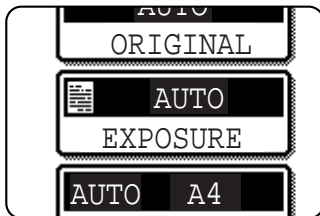

See steps 1 to 8 of "Making copies with the automatic document feeder" on pages 4-7 to 4-8 and "ADJUSTING THE EXPOSURE" on page 4-14.

- 2 Touch the [QUICK FILE] key in the main screen.**

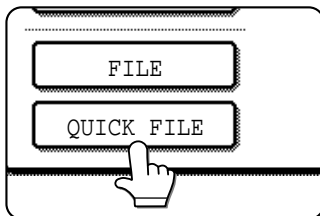

The [QUICK FILE] key will be highlighted to indicate that the function is selected.

If the [FILE] key is greyed out, only the [QUICK FILE] key can be selected.

When you touch the [QUICK FILE] key, a message asking you to confirm the save will appear. Touch the [OK] key in the message screen and go to the next step.

If you wish to cancel the save, touch the [QUICK FILE] key after touching the [OK] key so that the [QUICK FILE] key is no longer highlighted.

- 3 Press the [START] key on the operation panel.**

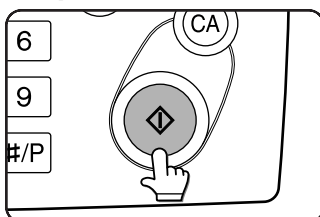

To prevent accidental saving of the document, the warning "THE SCANNED DATA IS STORED IN THE QUICK FILE FOLDER." appears for 6 seconds

after the [START] key is pressed.

When copying begins, the image is saved.

- 4 The saved image can be called up from the Quick File folder or the job status screen.**

- To call the image up from the Quick File folder, see "Calling up and using a saved file" on page 7-15.

- To call the job up from the finished job status screen, see "Calling up and manipulating a file from the job status screen" on page 7-20.

- 5 The following operations can be performed on the image that was called up in step 4.**

- Print the image (page 7-16)
- Transmit the image (page 7-17)
- Change the attribute (page 7-18)
- Move the image (page 7-19)
- Delete the image (page 7-19)
- Check details on the image (page 7-19)

Filing

When printing or transmitting a document in copy mode, printer mode, or image send mode, "FILE" can be selected to save an image of the document to the main folder or a previously created custom folder. The image can be called up at a later time, allowing you to print or transmit the document without having to locate the original.

NOTE

As an example, the procedure for using the filing function while copying using the automatic document feeder is explained below.

1 Place the originals in the document feeder tray and select resolution and exposure settings.

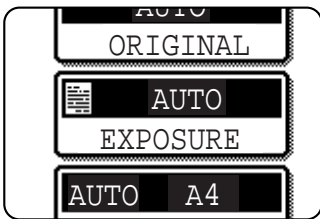

See steps 1 to 8 of "Making copies with the automatic document feeder" on pages 4-7 to 4-8 and "ADJUSTING THE EXPOSURE" on page 4-14

2 Touch the [FILE] key in the main screen.

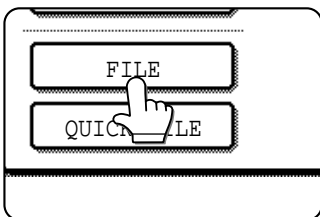

An information entry screen appears.

3 Touch the [USER NAME] key.

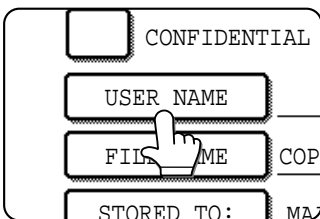

4 Touch the desired user name in the list of user names that appears.



User names must be previously stored ("Programming a user name" on page 7-22).

5 Touch the [OK] key.

The touched user name is selected and you return to the screen of step 3. The selected user name appears.

NOTE

If you do not select a user name, the following name is automatically selected:
Example : User unknown

6 Touch the [FILE NAME] key.

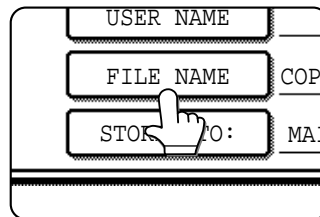

A character entry screen appears. Enter a file name (maximum of 30 characters). (See page 7-26 to enter characters.)

NOTE

If you do not enter a file name, a file name in the following format is automatically assigned:
Auto generated file name : Month, day, year, hour, minute, second, AM/PM
(Example : COPY_10012004_014050PM)

7 Touch the [STORED TO:] key.

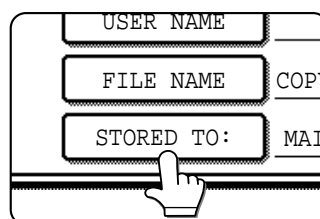

8 Touch the desired folder name in the list of folder names that appears

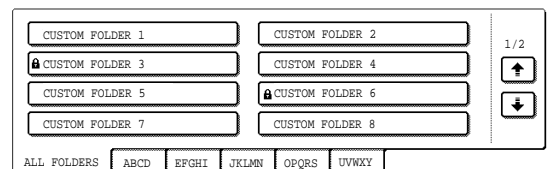

Folder names must be previously stored. ("Creating a custom folder" on page 7-24). If a password has been set for the folder, a password entry screen will appear. Enter the 5-digit password for the folder.

9 Touch the [OK] key.

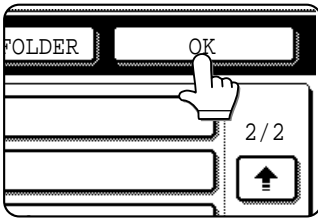

The touched folder is selected and you return to the screen of step 7. The selected folder name is displayed.

10 If needed, select the [CONFIDENTIAL] checkbox (only in copy mode).

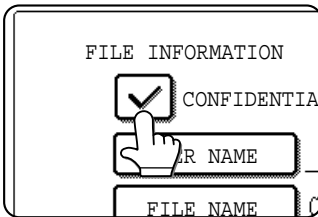

When this is selected, the file is stored with the attribute [CONFIDENTIAL]. To call up the file, the password that will be set in the following steps must be entered.

- If you selected the [CONFIDENTIAL] checkbox, touch the [PASSWORD] key and enter a password.
- If you did not select the [CONFIDENTIAL] checkbox, go to step 16. The file will be saved as a [SHARING] file.

11 Touch the [PASSWORD] key.

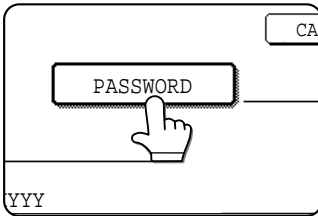

The password entry screen appears.

12 Enter a 5-digit password with the numeric keys.

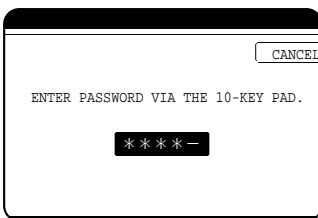

As each digit is entered, "-" changes to "*".

13 Touch the [OK] key.



14 You will return to the screen of step 10. The set password is displayed with "*".

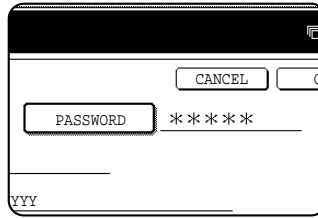

15 Touch the [OK] key.

You will return to the main screen.

16 Press the [START] key on the operation panel.

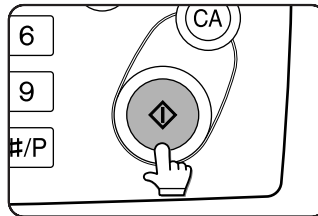

When copying begins, the image is saved.

17 The saved image can be called up using the file name, folder name, or user name, or from the filing folder.

- To call up the image by entering the file name, folder name, or user name, see "Searching for and calling up a saved file" on page 7-13.
- To call up the image from the filing folder, see "Calling up and using a saved file" on page 7-15.

18 The following operations can be performed on the image that was called up:

- Print the image (page 7-16)
- Transmit the image (page 7-17)
- Change the attribute (page 7-18)
- Move the image (page 7-19)
- Delete the image (page 7-19)
- Check details on the image (page 7-19)

Print jobs

Print jobs sent to the machine using the machine's printer driver can be saved in the main folder or a previously created custom folder when printed. The saved print data can be called up and printed or transmitted without having to open the original file on your computer.

This section gives an overview of this function and explains the procedure for printing from the operation panel of the machine.

For the procedures that are performed at your computer when initiating printing such as selecting the save location and file attribute, see the printer driver Help file.

■ Using a print job file (printing, deleting, transmitting, etc.)

1 Press the [DOCUMENT FILING] key on the operation panel.

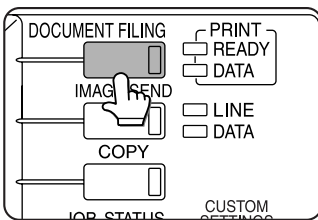

2 Touch the [FILE FOLDER] key or the [QUICK FILE FOLDER] key depending on where the file is saved.

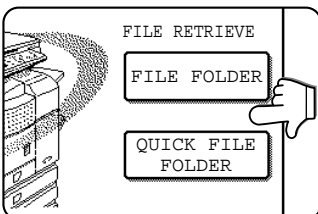

- Touch the [FILE FOLDER] key if the file is saved in the main folder or the custom folder. Touch the [QUICK FILE FOLDER] key if the file is saved in the Quick File folder.
- If you touched the [FILE FOLDER] key, the files in the main folder or the folders in the custom folder appear. If you open the wrong folder, touch the [MAIN FOLDER] key or the [CUSTOM FOLDER] key and open the correct folder.
- If the desired file is saved in the main folder, go to step 4. If the desired file is saved in a custom folder, go to step 3.
- If you touched the [QUICK FILE FOLDER] key, the files in the Quick File folder appear. Go to step 4.

3 Touch the key of the folder that contains the desired file.

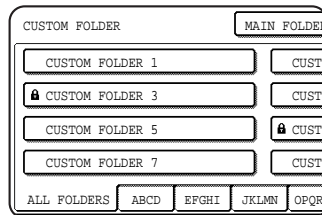

If a password is set for the selected folder, a password entry screen will appear. Enter the 5-digit password with the numeric keys.

4 Touch the printer icon (🖨️) tab and then touch the key of the desired file.

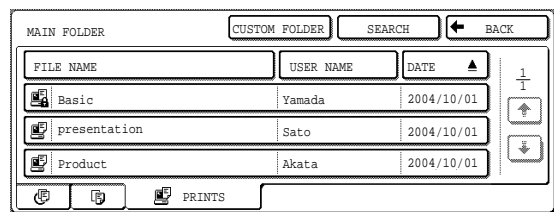

The following screen appears if the [QUICK FILE FOLDER] key is touched in step 2.

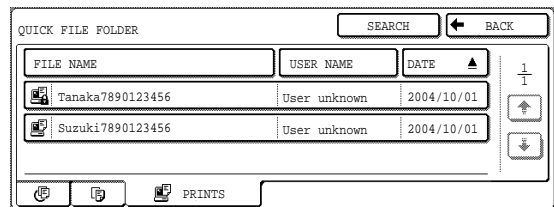

Touch the key of the file that you wish to call up. A menu screen will appear.

If a password is set for the file, a password entry screen will appear. Enter the 5-digit password with the numeric keys.

5 Touch the key of the operation that you wish to perform.

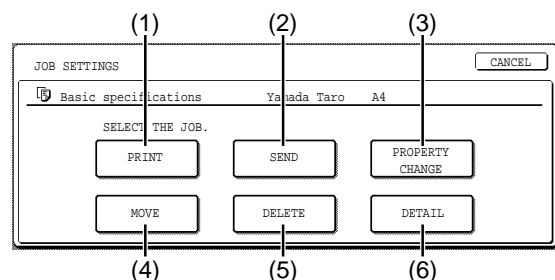

- (1) [PRINT] key (see page 7-16)
- (2) [SEND] key (see page 7-17)
- (3) [PROPERTY CHANGE] key (see page 7-18)
- (4) [MOVE] key (see page 7-19)
- (5) [DELETE] key (see page 7-19)
- (6) [DETAIL] key (see page 7-19)

The setting screen of the selected operation appears. See the indicated page.

Scan Save

Scan save is used to save a scanned document image in the main folder or the custom folder without copying or transmitting it.

1 Press the [DOCUMENT FILING] key on the operation panel.

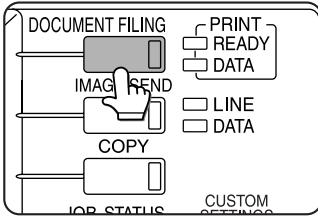

2 Touch the [SCAN TO HDD] key.



3 Touch the [SPECIAL MODES] key.

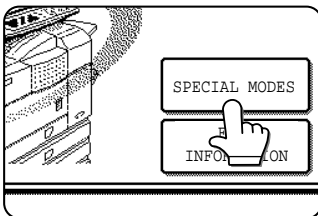

Select any special functions that you wish to use (otherwise skip this step).

When the [SPECIAL MODES] key is touched, the special modes

selection screen appears. (See "Using special functions for scan save." on page 7-12.)

NOTE

For explanations of the special functions, see page 7-12 and chapter 5.

4 Touch the [FILE INFORMATION] key.

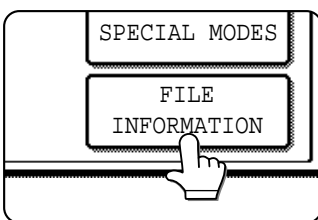

5 The screens for selecting the user name, file name, folder, and attribute appear. Configure the settings as explained in step 3 to step 15 on pages 7-7 to 7-8. When step 15 is completed, you will return to the main screen of document filing.

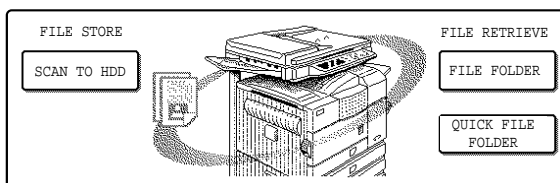

6 Perform any of the following steps 7 to 16 as needed. When finished, go to step 17 on page 7-11.

- To set the original size, perform steps 7 to 10.
- To set the resolution, perform steps 11 to 13 on page 7-11.
- To select the exposure, perform steps 14 to 16 on page 7-11.
- If you do not wish to select any of the above settings, go to step 17 on page 7-11.

7 Touch the [ORIGINAL] key.

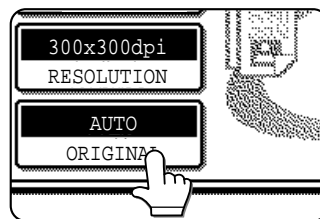

8 To set the original size, see "Manually setting the scanning size" on page 4-5.

9 If the original is two-sided, touch the [2-SIDED BOOKLET] key or the [2-SIDED TABLET] key depending on where the pages are bound.

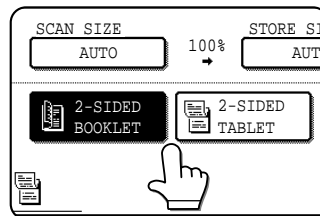

10 Touch the [OK] key.

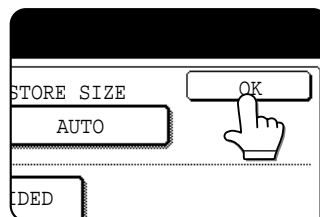

You will return to the screen of step 7.

NOTE

If the original pages are bound at the side, the document is a "booklet". If the original pages are bound at the top, the document is a "tablet".

11 Touch the [RESOLUTION] key.

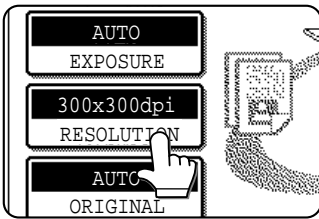

12 Touch the key of the desired resolution.

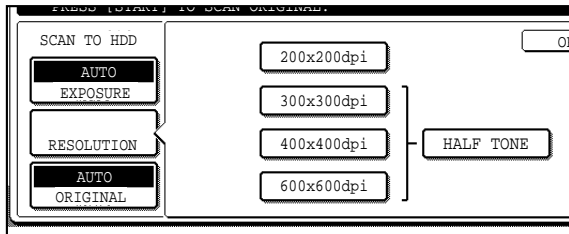

Select one of four resolution levels as appropriate for the original.

The selected resolution key is highlighted.

13 Touch the [OK] key.

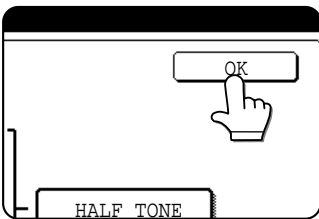

You will return to the screen of step 11.

14 Touch the [EXPOSURE] key.

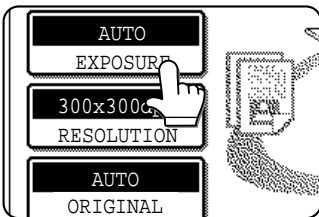



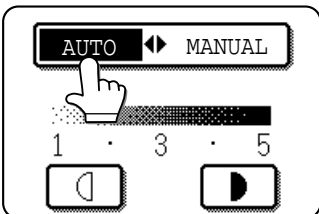

15 Select [AUTO] or [MANUAL].

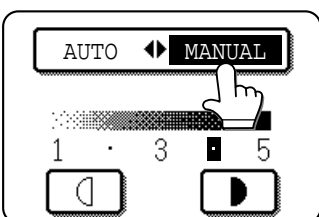

To have the exposure adjusted automatically, select [AUTO].



If you selected [MANUAL], touch the  or  key to adjust the exposure.

(For a darker image, touch the  key. For a lighter image, touch the  key.)

16 Touch the [OK] key.

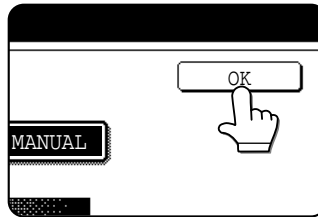

You will return to the screen of step 14.

17 Place the original and touch the [START] key.

[Placing the original]

- For information on placing the original, see "NORMAL COPYING" in chapter 4.
- If you selected the "Card Shot" special function, the document glass must be used.
- If you selected job build mode, the automatic document feeder must be used.

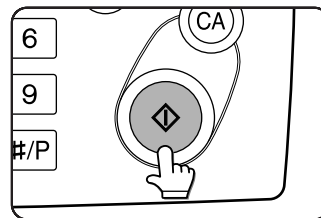

Scanning begins.

If you are using the document glass, touch the [READ-END] key after all pages have been scanned.

NOTE

This completes the scan save procedure. Follow the steps below when you wish to call up the image and print or transmit it.

18 The saved image can be called up using the file name, folder name, or user name, or from the filing folder.

- To call up the image by entering the file name, folder name, or user name, see "Searching for and calling up a saved file" on page 7-13.
- To call up the image from the filing folder, see "Calling up and using a saved file" on page 7-15.

19 The following operations can be performed on the image that was called up in step 18:

- Print the image (page 7-16)
- Transmit the image (page 7-17)
- Change the attribute (page 7-18)
- Move the image (page 7-19)
- Delete the image (page 7-19)
- Check details on the image (page 7-19)

■ **Using special functions for scan save.**

Touch the [SPECIAL MODES] key in the main scan save screen to display the special modes screen. The functions below can be selected in this screen.

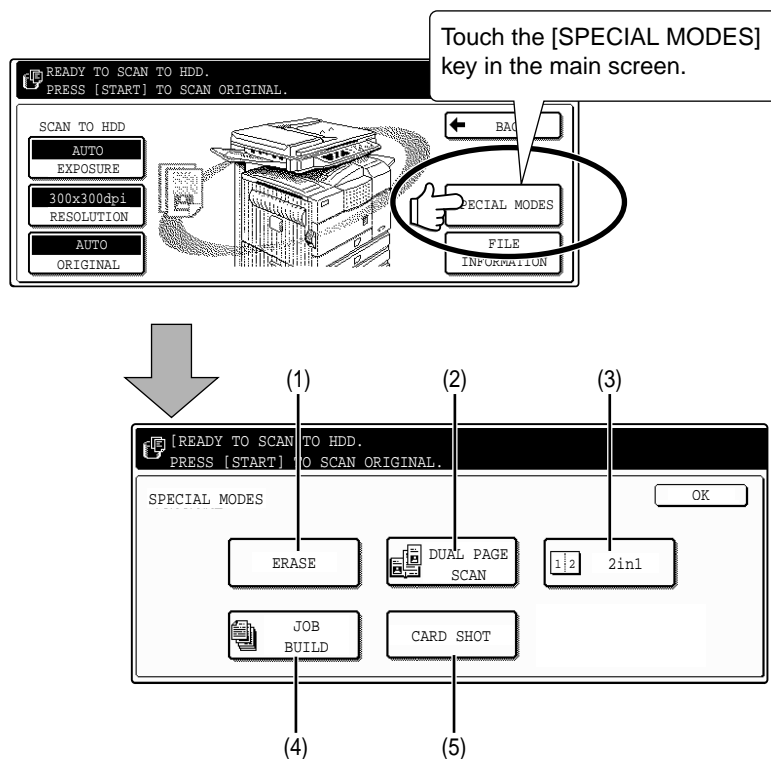

(1) [ERASE] key (see page 5-4)

Use this function to erase shadows that can appear around the edges of the image when books and other thick originals are scanned.

**(2) [DUAL PAGE SCAN] key (see page 5-5)
(Equivalent to Dual page copy in copy mode)**

This function is used to save the opened pages of a book in order one page at a time (left page then right page).

**(3) [2in1] key (see page 5-23)
(When the fax or network scanner option is installed, this is equivalent to the 2in1 function described in the fax and network scanner manuals. It is also equivalent to the "Multi shot" function in copy mode; however, only 2in1 is possible for scan save.)**

This function reduces two original pages and arranges the images on a single page in a uniform layout.

(4) [JOB BUILD] key (see page 5-8)

When you have more pages than can be placed in the document feeder at once, this function allows you to scan the pages in sets.

(5) [CARD SHOT] key (see page 5-26)

This function allows you to save the front and back side of a card on a single page (instead of saving each side as a separate file).

CALLING UP AND USING A FILE

Searching for and calling up a saved file

When calling up a file, you can enter the file name, folder name, or user name to quickly search for the file.

To search for a file, touch the [SEARCH] key in the main screen of document filing mode or in a screen that shows folders or files in a folder. A data search screen will appear.

■ Procedure for searching for a file

- 1 Touch the [SEARCH] key in the main screen of document filing mode or in a screen that shows folders or files in a folder.

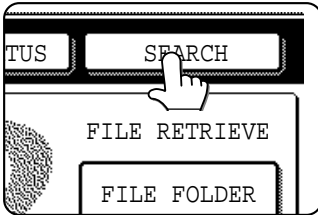

If you touch the [SEARCH] key in the screen that shows the folders in the custom folder or a screen that shows the files in a folder, the [SEARCH

WITHIN CURRENT FOLDER] checkbox will appear. Select this checkbox to search for a file only in the selected folder.

- 2 In the data search screen, select whether you will search by [USER NAME] or [FILE OR FOLDER NAME].

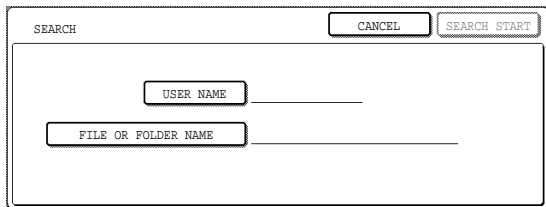

- To search by user name, follow steps 3 to 6.
- To search by file name or folder name, perform step 8.
- To stop searching, touch the [CANCEL] key.

[Searching by user name]

- 3 Touch the [USER NAME] key.

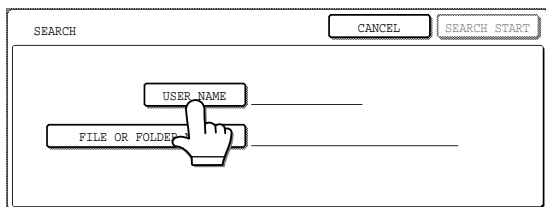

- 4 Touch the one-touch key of the user name that you wish to use to search for the file. If you wish to directly enter the user name, touch the [DIRECT ENTRY] key.

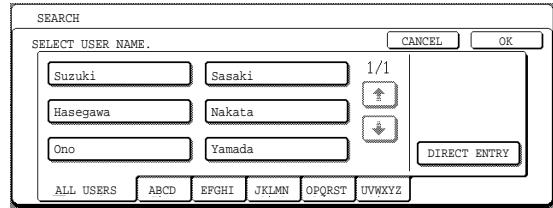

- The selected user name is highlighted.
- If you select the wrong user name, touch the key of the correct name.
- If you touch the [DIRECT ENTRY] key, a character entry screen will appear. Enter the user name. See page 7-26 for the procedure for entering characters.

- 5 Touch the [OK] key.

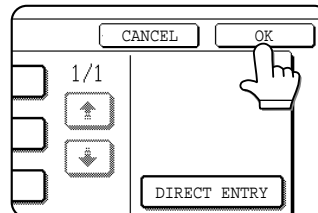

You will return to the screen of step 2 and the selected user name will appear.

- 6 Touch the [SEARCH START] key.

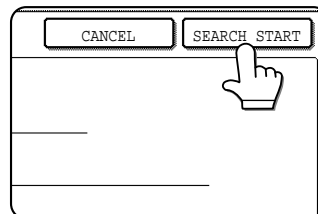

7 The results of the user name search appear. Touch the desired file name or folder name.

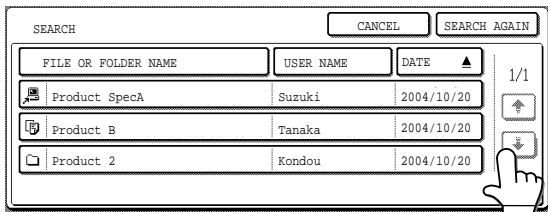

- See page 7-5 for a list of the document filing icons.
- When a file name is touched, the operation selection screen appears. **(To perform an operation using the file, go to step 5 on page 7-16.)**
- When a folder name is touched, all files in the folder are displayed. Touch the desired file. **(To perform an operation using the file, go to step 5 on page 7-16.)**
- To change the order of file display, touch the [FILE OR FOLDER NAME] key, [USER NAME] key, or [DATE] key.
If you touch a file name or folder name that has a password, a password entry screen will appear. Enter the 5-digit password with the numeric keys.

10 The results of the file or folder name search appear. Touch the desired file name or folder name.

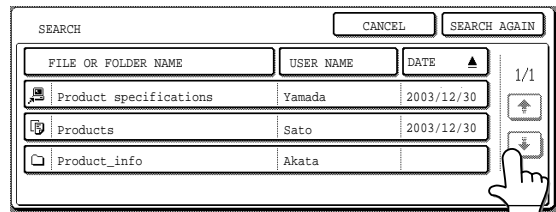

- See page 7-5 for a list of the document filing icons.
- When a file name is touched, the operation selection screen appears. **(To perform an operation using the file, go to step 5 on page 7-16.)**
- When a folder name is touched, all files in the folder are displayed. Touch the desired file. **(To perform an operation using the file, go to step 5 on page 7-16.)**
- To change the order of file display, touch the [FILE OR FOLDER NAME] key, [USER NAME] key, or [DATE] key.
If you touch a file name or folder name that has a password, a password entry screen will appear. Enter the 5-digit password with the numeric keys.

[Searching by file or folder name]

8 Touch the [FILE OR FOLDER NAME] key.

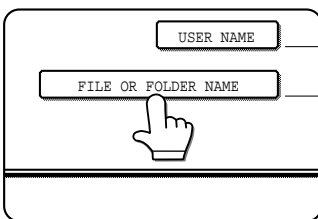

A character entry screen appears. Enter the file name or folder name to be used for the search. See page 7-26 to enter characters.

9 Touch the [SEARCH START] key.

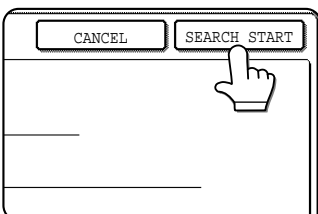

Calling up and using a saved file

A file saved with the document filing function can be called up and printed or manipulated as needed. The following operations can be performed:

- **[Print]** : Print the file (page 7-16).
- **[Send]** : Transmit the saved file (page 7-17). The file can be transmitted by Scan to E-mail, Scan to FTP, fax, or Internet fax. (All of these methods require installation of the appropriate options.) (Page 1-11)
- **[Property change]** : Change the attribute of the saved file (page 7-18).
- **[Move]** : Move the file (page 7-19)
- **[Delete]** : Delete the file (page 7-19)
- **[Detail]** : Show details on the saved file (page 7-19).

■ General procedure for using a saved file

1 Press the **[DOCUMENT FILING]** key on the operation panel.

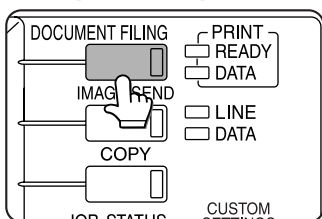

2 Touch the **[FILE FOLDER]** key or the **[QUICK FILE FOLDER]** key depending on where the file is saved.

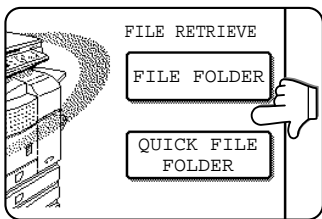

- Touch the **[FILE FOLDER]** key if the file is saved in the main folder or the custom folder. Touch the **[QUICK FILE FOLDER]** key if the file is saved in the Quick File folder. If you touched the **[FILE FOLDER]** key, the files in the main folder or the folders in the custom folder appear. If you open the wrong folder, touch the **[MAIN FOLDER]** key or the **[CUSTOM FOLDER]** key and open the correct folder.
- If the desired file is saved in the main folder, go to step 4. If the desired file is saved in a custom folder, go to step 3.
- If you touched the **[QUICK FILE FOLDER]** key, the files in the Quick File folder appear. Go to step 4.

3 Touch the key of the folder that contains the desired file.

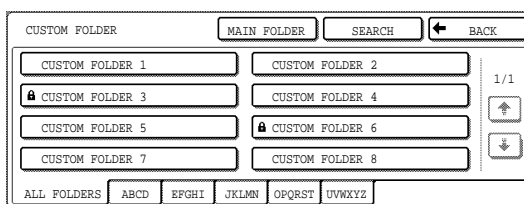

If there are more custom folder keys than can appear in one screen, touch the or keys to change screens.

If a password is set for the selected folder, a password entry screen will appear. Enter the 5-digit password with the numeric keys.

4 Touch the desired file key.

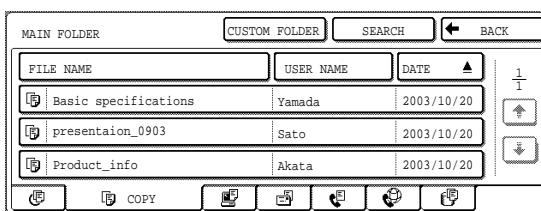

5 Touch the key of the operation that you wish to perform.

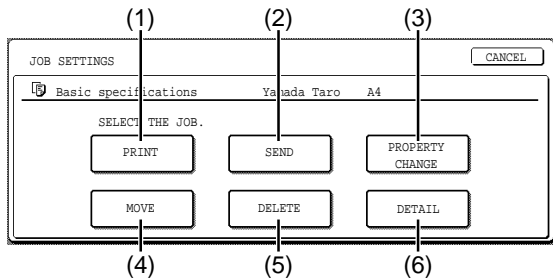

- (1) [PRINT] key (see below)
- (2) [SEND] key (see page 7-17)
- (3) [PROPERTY CHANGE] key (see page 7-18)
- (4) [MOVE] key (see page 7-19)
- (5) [DELETE] key (see page 7-19)
- (6) [DETAIL] key (see page 7-19)

The setting screen of the selected operation appears. See the indicated page.

■ [Print]

A saved file can be printed.

The screen below appears when the [PRINT] key is selected in the operation selection screen. To begin printing, touch the [PRINT] (7) key. Printing settings can be selected in this screen before printing. The settings that were in effect when the file was saved appear initially. The settings can be changed as needed.

NOTES

- When print settings are changed with this procedure, only the value for the number of copies is overwritten.
- The printing speed will be slower for image files saved using certain resolution settings. (See page 7-28.)

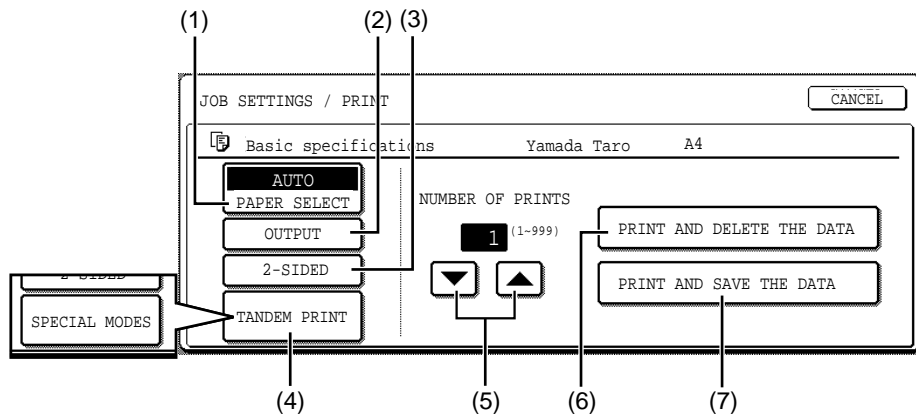

(1) [PAPER SELECT] key

Use this key to set the paper size.

(2) [OUTPUT] key

Use this key to select sort, group or staple sort functions, and to select the output tray.

(3) [2-SIDED] key

When performing two-sided printing, use this key to select the orientation of the image on the back side of the paper. To have the front and back images oriented in the same direction, touch the [2-SIDED BOOKLET] key. To have the front and back images oriented opposite to each other, touch the [2-SIDED TABLET] key. Note that the size and orientation of the saved image may cause these keys to have the opposite effect. If neither key is selected, one-sided printing will take place.

To perform two-sided printing, the optional duplex module is necessary.

(4) [TANDEM PRINT] key

If the conditions for tandem printing are met (page 5-9), touch this key to enable tandem printing. See page 5-9 for more information.

When printing a file that was saved in copy mode, this key changes to the [SPECIAL MODES] key. The [SPECIAL MODES] include [PRINT MENU] and [TANDEM PRINT]. For information on the print menu, see page 5-29.

(5) [NUMBER OF PRINTS] setting key

Use this key to set the number of copies.

(6) [PRINT AND DELETE THE DATA] key

Touch this key to print a file and then have it automatically deleted.

(7) [PRINT AND SAVE THE DATA] key

Touch this key to print a file. The file will not be automatically deleted after printing.

■ [Send]

A saved file can be transmitted by Scan to E-mail, Scan to FTP, fax, or Internet fax. These transmission methods require installation of the appropriate options.

The following screen appears when the [SEND] key is touched. Select the destination and other settings required for transmission and then touch the [SEND] (10) key to transmit the file. Transmission settings include the resolution and transmission functions such as a timer setting. Change or select these settings as needed.

NOTE
Jobs that use the following special functions cannot be transmitted when called up. (The [SEND] key is greyed out in the operation selection screen.)
Pamphlet copying, covers/insert, card shot, Multi shot.
Jobs that use the following functions can be transmitted with certain restrictions when called up:
Card shot: Can be transmitted if saved by scan save or image send.
Multi shot (2in1): Can be transmitted if saved as 2in1 using a portrait original.

[Example of E-MAIL/FTP mode]

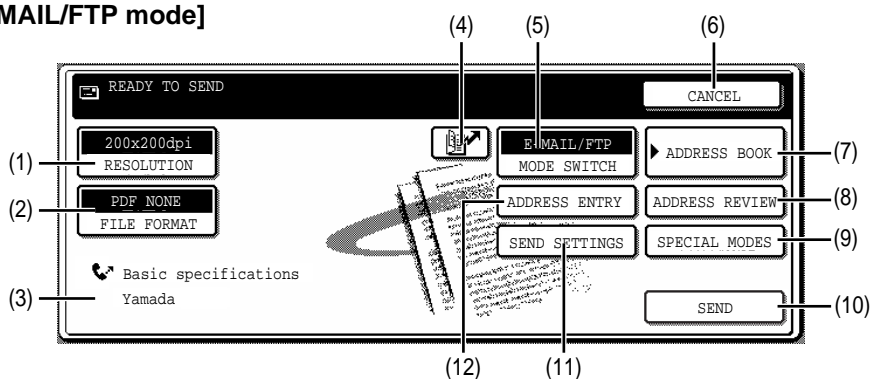

(1) [RESOLUTION] key

Use this key to set the resolution. The resolution is set when performing Scan to E-mail/FTP and the resolution is set when performing a fax or Internet fax transmission.

(2) [FILE FORMAT] key

[FILE FORMAT] key is displayed in E-mail/FTP mode. Touch this key to set the file format of scan images that you transmit.

(3) [FILE NAME/USER NAME] display

This shows the file name and user name of the file to be transmitted.

(4) [[Speed dial key]

Use this key to specify a destination by entering the 3-digit number that is assigned to an e-mail address or fax number when it is stored in a one-touch key or group key.

(5) [MODE SWITCH] key

Use this key to select the transmission mode (Scan to E-mail/FTP, fax, or Internet fax).

(6) [CANCEL] key

Touch this key to return to the operation selection screen.

(7) [ADDRESS BOOK] key

Touch this key to display the destinations stored in the directory.

(8) [ADDRESS REVIEW] key

Touch this key to display the destinations.

(9) [SPECIAL MODES] key

Touch this key to display the special function menu. The functions that can be selected vary depending on the transmission mode:

- Scan to E-mail/FTP
TIMER : The transmission time can be specified.
- FAX
TIMER : The transmission time can be specified.
FAX OWN ADDRESS SENDING: Your sender's information can be included on the fax pages printed out by the receiving machine.
TRANSACTION REPORT: A transaction report can be printed based on the specified conditions after a transaction ends.
- Internet FAX
TIMER : The transmission time can be specified.
I-FAX OWN ADDRESS SEND: Your sender's information can be included on the Internet fax pages printed out by the receiving machine.
TRANSACTION REPORT: A transaction report can be printed based on the specified conditions after a transaction ends.

(10) [SEND] key

Touch this key after selecting transmission settings to begin transmission. (The [START] key can also be pressed to begin transmission.)

(11) [SEND SETTINGS] key

[SEND SETTINGS] key is displayed in E-mail/FTP mode and Internet FAX mode.
Touch this key to set the subject and file name. In E-mail/FTP mode, sender name can also be set.

(12) [SUB ADDRESS] key or [ADDRESS ENTRY] key

- Touch this key to directly enter the destination for a Scan to E-mail/FTP or Internet fax transmission, .
- Touch this key to enter the sub-address and passcode for an F-code fax transmission.

NOTE
See the "Operation manual (for facsimile)" and "Operation manual (for network scanner)" for detailed explanations of (1), (2), (3), (4), (5), (6), (7), (8), (9), (11), and (12).

■ **[Property change]**

Select this operation to change the attribute of a saved file. Three attributes are available: [SHARING], [PROTECT], and [CONFIDENTIAL].
The following screen appears when the [PROPERTY CHANGE] key is selected in the operation selection screen. Note the restrictions below on changing the attribute.

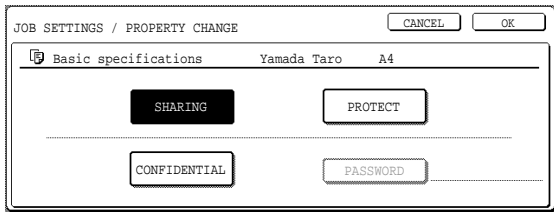

[Restrictions on changing the attribute]

- A file that is set to [SHARING] can be changed to [PROTECT] or [CONFIDENTIAL]. However, a [SHARING] file that is saved in the Quick File folder can only be changed to [PROTECT].
- A file that is set to [PROTECT] can be changed to [SHARING] or [CONFIDENTIAL]. However, a [PROTECT] file that is saved in the Quick File folder can only be changed to [SHARING].
- A file that is saved in the Quick File folder cannot be changed to [CONFIDENTIAL].

1 Touch the [PROPERTY CHANGE] key in the operation selection screen.

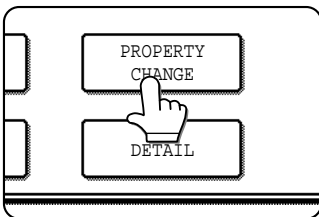

3 Touch the [OK] key.

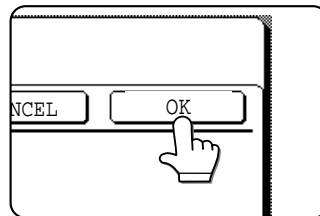

2 Touch the key of the desired attribute.

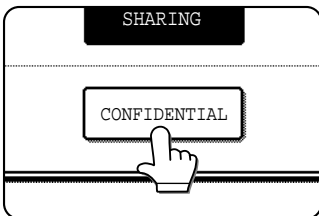

If you are changing a [SHARING] or [PROTECT] file to [CONFIDENTIAL], touch the [PASSWORD] key and enter the password.

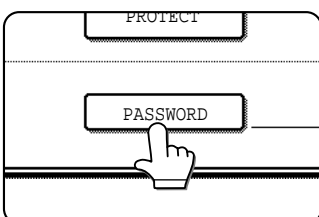

■ **[Move]**

This operation is used to move a file to a different folder.

The following screen appears when the [MOVE] key is selected.

Only [SHARING] and [CONFIDENTIAL] files can be moved. A [PROTECT] file can be moved by first using [PROPERTY CHANGE] to change the attribute to [SHARING] or [CONFIDENTIAL].

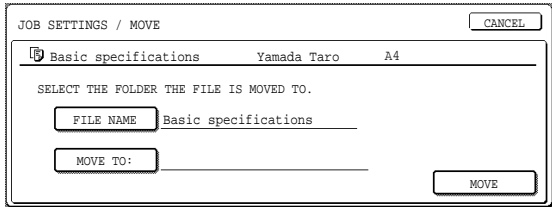

1 Touch the [MOVE TO:] key and select the folder to which you wish to move the file.

- Select the main folder or a folder in the custom folder. A file cannot be moved to the Quick File folder.
- The file name can be changed when moving a file. To change the name, touch the [FILE NAME] key and enter the desired file name. See page 7-26 for the procedure for entering characters.

2 Touch the [OK] key.

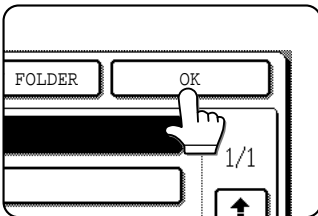

3 Touch the [MOVE] key.

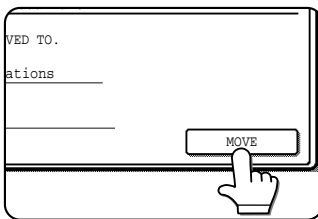

4 Touch the [CANCEL] key.

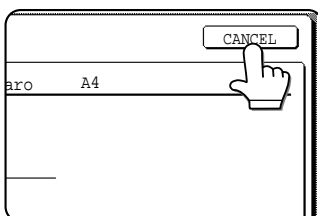

You will return to the operation selection screen.

■ **[Delete]**

This operation is used to delete the selected file. Touch the [DELETE] key in the operation select screen. A message asking you to confirm the deletion will appear. Touch the [YES] key to delete the file.

Only [SHARING] or [CONFIDENTIAL] files can be deleted. (A [PROTECT] file can be deleted by first using [PROPERTY CHANGE] to change the attribute to [SHARING].)

■ **[Detail]**

This operation is used to show detailed information on the selected file.

Touch the [DETAIL] key to display the information. The information appears on two screens. Touch the [↓] key or [↑] key to move between the two screens.

The file name can be changed in the information screen. To change the name, touch the [FILE NAME] key and enter the desired file name in the character entry screen that appears. See page 7-26 for the procedure for entering characters.

■ Calling up and manipulating a file from the job status screen

Files saved using the "FILE" and "QUICK FILE" functions appear as keys in the finished job status screen. You can view information on a file that appears in this screen and manipulate the file.

1 Press the [JOB STATUS] key.

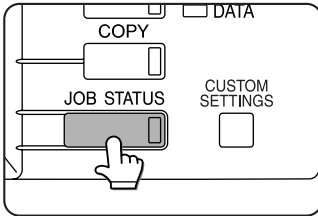

The job status screen appears.

4 To view information on the file, touch the [DETAIL] key.

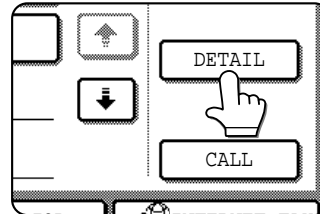

Use the keys to change screens.

When you are finished, touch the [OK] key to return to the screen of step 3.

2 Touch the [COMPLETE] key.

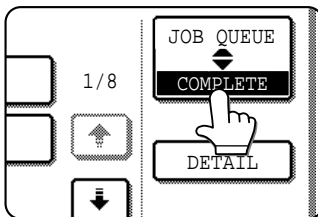

The finished job screen appears.

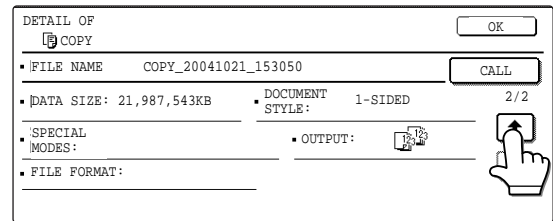
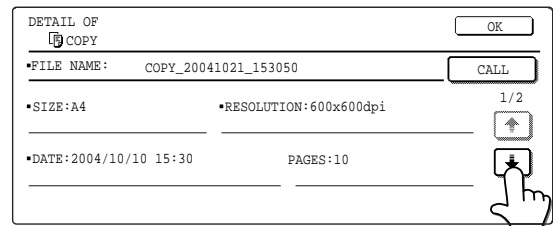

3 Touch the key of the desired file.

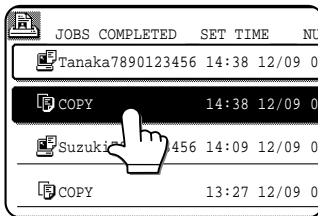

If there are more keys than can appear in one screen and the desired file does not appear, touch the key or key to change screens.

The touched key is highlighted.

5 Touch the [CALL] key.

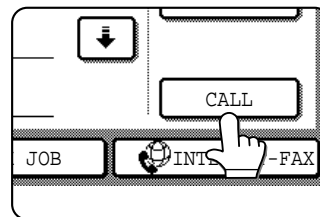

The operation selection screen appears.

Select and perform the desired operation as explained in "Calling up and using a saved file" (page 7-15).

CUSTOM SETTINGS

Creating, editing, and deleting user names and folders

This section explains how to create, edit, and delete user names and custom folders for saving files with the document filing function. User names and custom folders are created and edited at the operation panel of the machine or in the Web page.

NOTES

- A previously stored name cannot be used when creating a new user name or custom folder. However, the same password can be used more than once.
- A password cannot be omitted when creating a user name.

■ General procedure for creating, editing, and deleting user names and folders

Follow steps 1 to 3 below to create, edit, or delete a user name or custom folder. In step 3, select the key for the specific operation that you wish to perform.

1 Press the [CUSTOM SETTINGS] key.

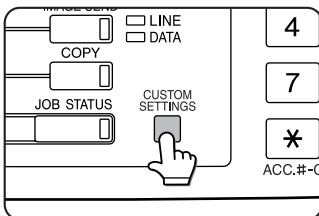

2 Touch the [DOCUMENT FILING CONTROL] key.

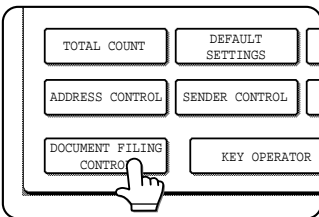

3 Touch the key of the operation that you wish to perform.

Go to the page indicated below for the selected operation.

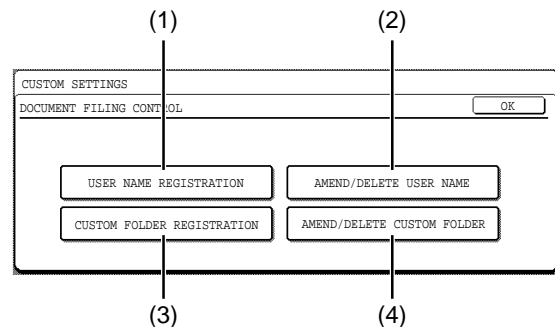

- (1) **[USER NAME REGISTRATION] key**
Program a user name. (See the next page)
- (2) **[AMEND/DELETE USER NAME] key**
Edit or delete a user name. (See page 7-23)
- (3) **[CUSTOM FOLDER REGISTRATION] key**
Create a custom folder. (See page 7-24)
- (4) **[AMEND/DELETE CUSTOM FOLDER] key**
Edit or delete a custom folder. (See page 7-25)

■ Programming a user name

To program a user name, follow steps 1 and 2 on page 7-21, touch the [USER NAME REGISTRATION] key in step 3, and then follow these steps:

1 Touch the [USER NAME] key.

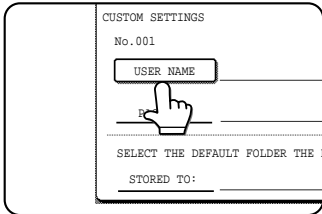

The lowest number that has not yet been programmed appears automatically in "No.". Touch the number to display a character entry screen and enter a user name (maximum of 16 characters). See page 7-26 for the procedure for entering characters.

2 Touch the [INITIAL] key.

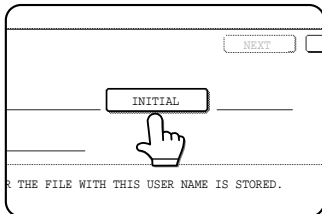

A character entry screen appears. Enter up to 10 search characters. See page 7-26 for the procedure for entering characters.

3 Touch the [PASSWORD] key.

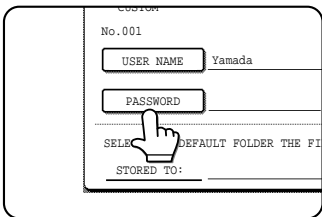

A password cannot be omitted.

4 Set a password for the user name (enter a 5-digit password with the numeric keys).



This will be the password for the user name entered in step 1. As each digit is entered, "-" changes to "*". If you make a mistake, press the [C] key and then enter the correct number.

5 Touch the [OK] key.

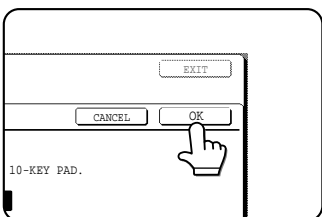

6 If you wish to specify a folder for the user name, touch the [STORED TO:] key. If you wish to use the main folder, go to step 8.

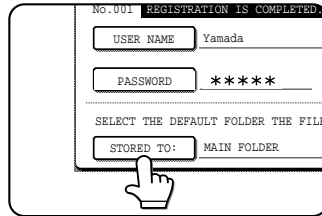

7 The folders that have been created appear. Touch the desired folder. If you wish to create a new folder, or if no folders have been created, touch the [ADD NEW] key.

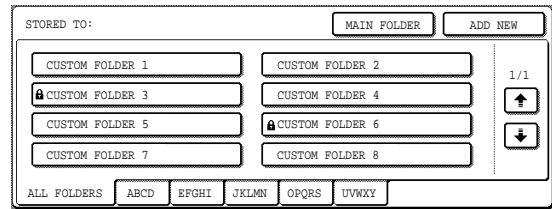

If you touched the [ADD NEW] key, program a name for the folder as explained on page 7-24.

The user name programmed in step 1 is selected as the user name of the folder.

8 Touch the [EXIT] key.

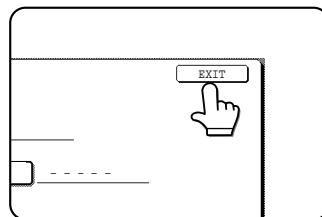

You will return to the "USER NAME REGISTRATION" screen. "REGISTRATION IS COMPLETED." will appear highlighted next to "No.".

9 To exit, touch the [EXIT] key. To program another user name, touch the [NEXT] key.

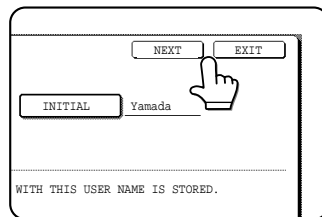

If you touched the [EXIT] key, you will return to the screen of step 3 on page 7-21. If you touched the [NEXT] key, a new user entry screen will appear. Repeat steps 1 to 9 to program a new user.

■ Editing and deleting a user name

To edit or delete a user name, follow steps 1 and 2 on page 7-21 and then follow these steps:

- 1 Touch the [AMEND/DELETE USER NAME] key.

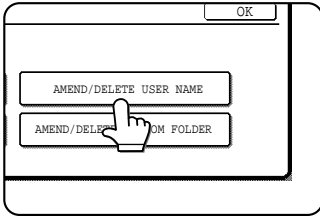

- 2 Touch the [USER NAME] key that you wish to edit or delete.

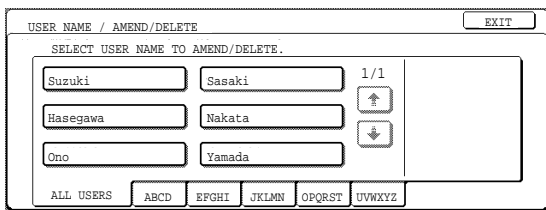

A password entry screen will appear.

- 3 Enter the 5-digit password with the numeric keys.

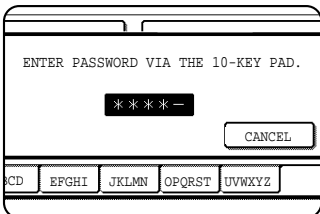

After entering the password, the following screen will appear.

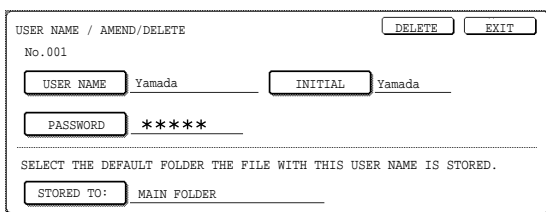

- To edit a user name, perform steps 4 and 5.
- To delete a user name, perform steps 6 and 7.

[Editing]

- 4 Touch the key of each item that you wish to edit (edit as explained in steps 1 to 9 in "Programming a user name" on page 7-22).

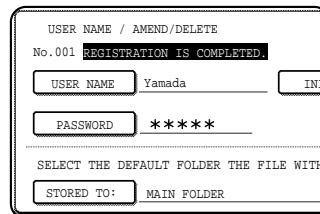

When you have finished editing the items, "REGISTRATION IS COMPLETED." will appear highlighted next to "NO."

- 5 When you have finished editing the desired items, touch the [EXIT] key.

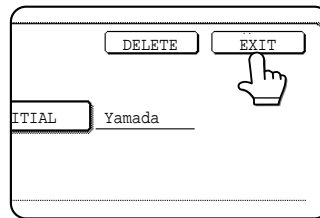

To edit another user name, repeat steps 2 to 4.

To exit, touch the [EXIT] key in the screen of step 2.

NOTE

When a user name is changed, the change is not updated to any previously saved data (files or folders).

[Deleting]

- 6 Touch the [DELETE] key.

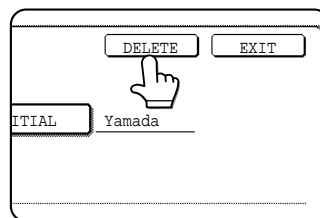

- 7 Touch the [YES] key.

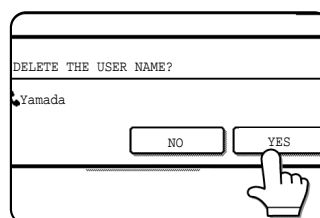

You will return to the screen of step 2. To delete another user name, repeat steps 2, 3 and 6.

To exit, touch the [EXIT] key in the screen of step 2.

■ Creating a custom folder

Up to 500 custom folders can be created. When no further folders can be created, delete unneeded folders (page 7-25) and then create a new folder. A password can be omitted when creating a folder. To create a custom folder, follow steps 1 and 2 on page 7-21, touch the [CUSTOM FOLDER REGISTRATION] key in step 3, and then follow the steps below.

1 Touch the [FOLDER NAME] key.

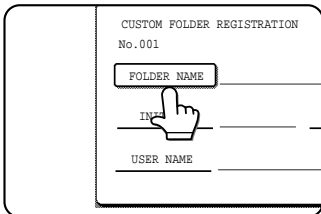

The lowest number that has not yet been programmed appears automatically in "No.". Touch the number to display a character entry screen and enter a

folder name (maximum of 28 characters). See page 7-26 for the procedure for entering characters.

2 Touch the [INITIAL] key.

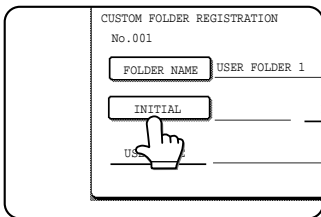

A character entry screen appears. Enter up to 10 search characters. See page 7-26 for the procedure for entering characters.

3 If you wish to set a password for the new folder, touch the [PASSWORD] key.

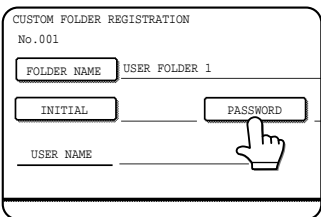

A password can be omitted. If you are omitting a password, go to step 6.

4 Set a password for the folder (enter a 5-digit password with the numeric keys).



This will be the password for the folder name entered in step 1.

5 Touch the [OK] key.

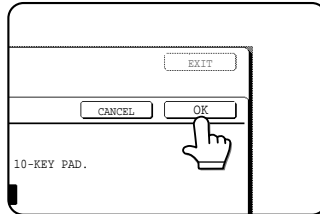

6 Touch the [USER NAME] key.

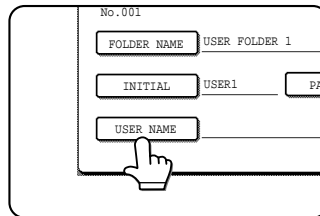

You will select a user name that will be associated with the folder name you are programming. Selection of a user name cannot be omitted.

7 The programmed user names appear. Touch the desired user name. If you do not wish to use any of the user names that appear, touch the [ADD NEW] key to program a new user name.

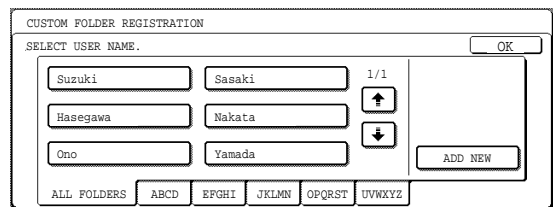

When you touch a user name, a password entry screen appears.

If you touched the [ADD NEW] key, program a user name as explained on page 7-22. The folder name programmed in step 1 will be selected as the folder for the user.

8 Enter the 5-digit password of the selected user name with the numeric keys.

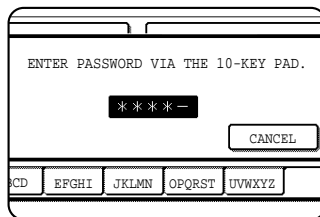

9 Touch the [OK] key.

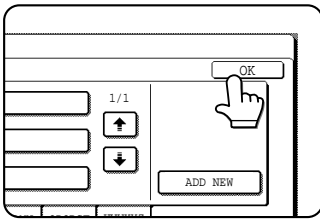

10 To exit, touch the [EXIT] key. To create another folder, touch the [NEXT] key.

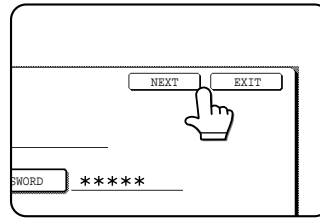

If you touched the [EXIT] key, you will return to the screen of step 3 on page 7-21. If you touched the [NEXT] key, a new folder screen will appear. Repeat steps 1 to 10 to

create a new folder.

■ Editing/deleting a custom folder

To edit a previously created folder (change the folder name, initial, password, or user name), or to delete a folder, follow steps 1 and 2 on page 7-21 and then follow the steps below.

When deleting a folder...

A folder that contains files cannot be deleted. Either move the files to a different folder or delete them before deleting the folder.
: [MOVE] (see page 7-19) : [DELETE] (see page 7-19)

1 Touch the [AMEND/DELETE CUSTOM FOLDER] key.

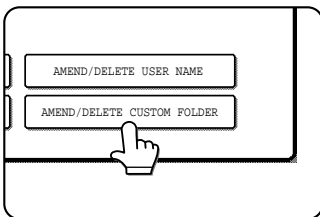

2 Touch the [FOLDER NAME] key that you wish to edit or delete.

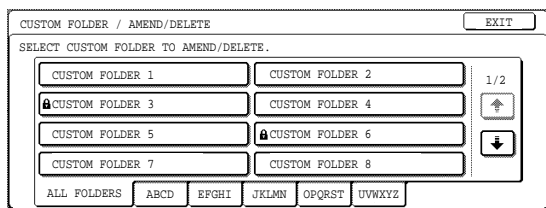

If a password has been set for the folder, a password entry screen will appear. Enter the correct 5-digit password with the numeric keys.

3 Edit or delete the folder.

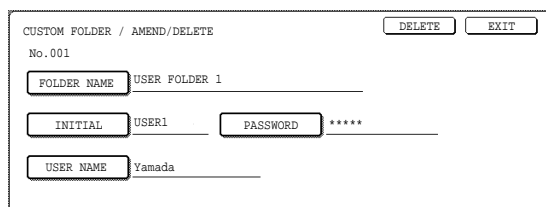

- To edit the folder, perform steps 4 and 5.
- To delete the folder, perform steps 6 and 7.
- To exit, touch the [EXIT] key.

[Editing]

4 Touch the key of each item that you wish to edit (edit as explained in steps 1 to 10 of "Creating a custom folder" on page 7-24).

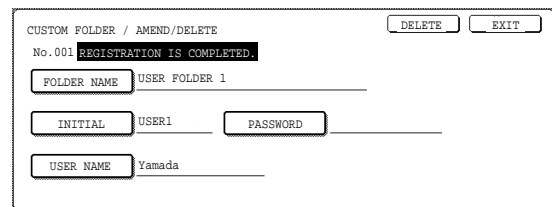

After editing the items and returning to the screen of step 3, "REGISTRATION IS COMPLETED." will be highlighted to the right of "No."

To stop using a password, touch the [PASSWORD] key and then touch the [OK] key without entering anything for the password. [-] will appear and the password will be cancelled.

5 When you have finished editing the items, touch the [EXIT] key.

To edit another folder, repeat steps 2 to 5.

[Deleting]

6 Touch the [DELETE] key.

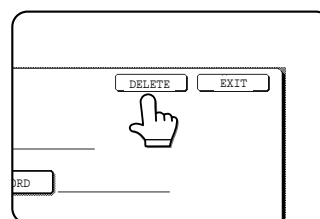

7 Touch the [YES] key.

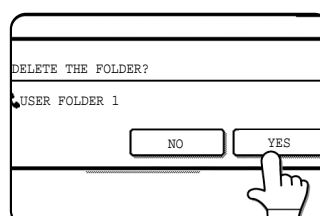

You will return to the screen of step 2.

To delete another folder, repeat steps 2, 6, and 7. To exit, touch the [EXIT] key in the screen of step 2.

ENTERING CHARACTERS

To enter or edit characters in setting screens such as auto dial key programming screens, follow the steps below. Characters that can be entered are alphabetical characters, special characters, numbers, and symbols.

■ Entering alphabetical characters

(Example: Olivetti äÄ)

1 Touch the [S] key.

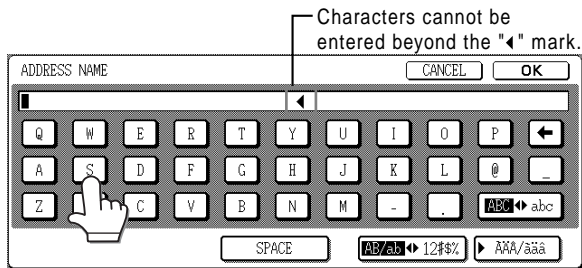

To switch between upper case and lower case, touch the [ABC ◀ abc] key. When ABC is highlighted, upper case letters are entered.

2 Touch the [ABC ◀ abc] key.

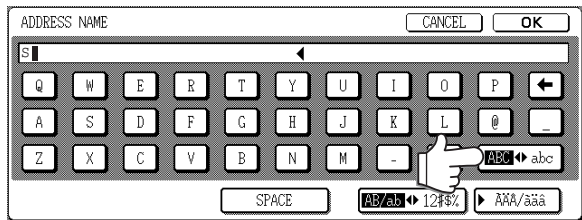

3 Touch the [h] key, [a] key, [r] key, and [p] key.

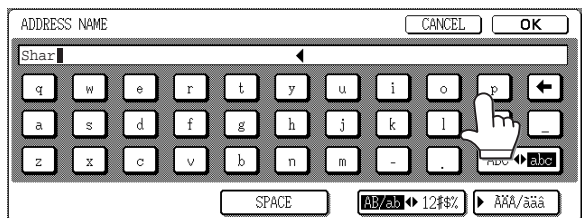

If you make a mistake, touch the [◀] key to move the cursor (█) back one space and then enter the correct character. You can also press the [AB/ab ◀ 12#\$%] key during entry to enter a number or symbol.

4 Touch the [SPACE] key.

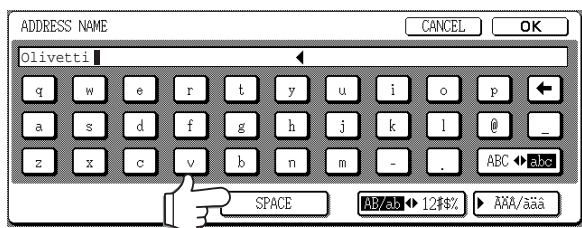

The cursor (█) moves forward and a space is entered.

5 Touch the [▶ ÄÄ/ää] key.

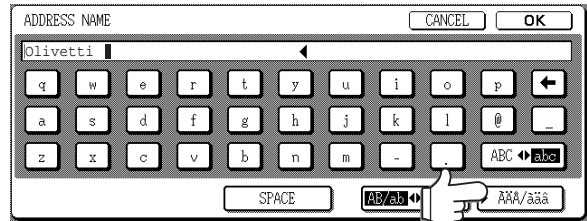

6 Touch the [ä] key.

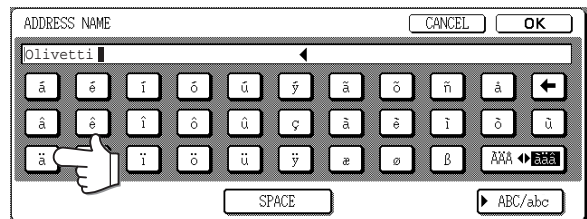

To switch between upper case and lower case, touch the [▶ ÄÄ ◀ äää] key. When äää is highlighted, lower case letters are entered.

7 Touch the [▶ ÄÄ ◀ äää] key.

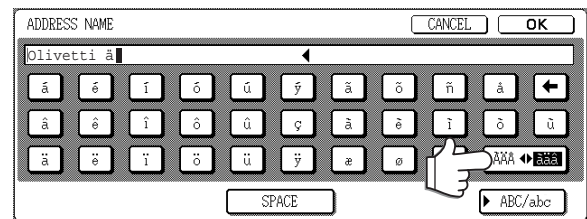

8 Touch the [Ä] key.

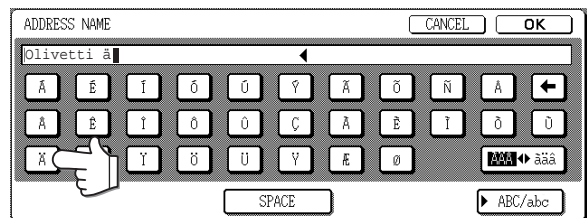

You can press the [ABC/abc] key during entry to return to alphabetical character entry. You can also enter numbers and symbols.

9 When finished, touch the [OK] key.

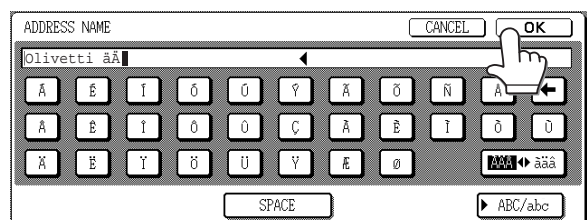

You will exit the character entry screen and return to the programming screen. If you touch the [CANCEL] key, you will return to the programming screen without storing the entered characters.

■ Entering numbers and symbols

1 Touch the [AB/ab ◀▶ 12#\$\$%] key.

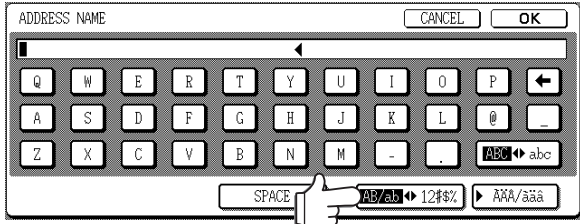

When the characters "12#\$\$%" are highlighted, number/symbol entry mode is selected.

2 Enter the desired number or symbol.

Numbers and symbols that can be entered are as follows:

Screen 1/2

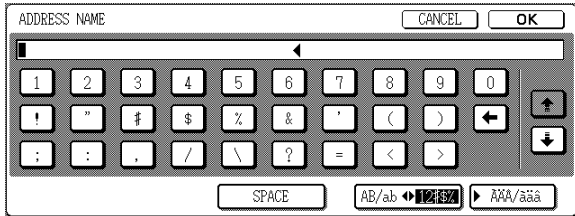

Screen 2/2

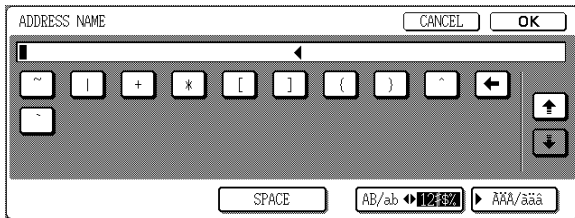

* Change screens by touching the key or key displayed in the screen. If you make a mistake, touch the key to move the cursor (■) back one space and then enter the correct character.

You can continue touching keys to enter characters. You can also touch another character type selection key ([▶ ÃÄ/ää] key or [AB/ab ◀▶ 12#\$\$%] key) to enter characters other than numbers and symbols.

3 When you have finished entering characters, touch the [OK] key.

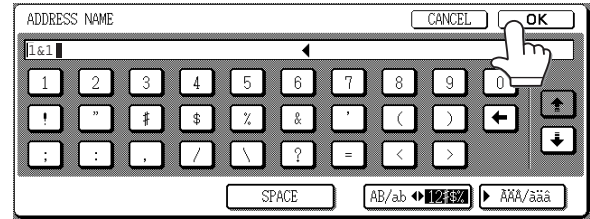

You will exit the character entry screen and return to the programming screen. If you touch the [CANCEL] key, you will return to the programming screen without storing the entered characters.

NOTE

The following symbols cannot be used when entering a file name or folder name.

\	?	/	"	;	:	,
<	>	!	*		&	#

TROUBLESHOOTING

This section explains problems frequently encountered when using the document filing function. If you experience any difficulty, refer to the following table. For information on general machine problems, printer problems, fax problems, and network scanner problems, please see the troubleshooting sections of the appropriate manuals.

Problem	Check	Cause and solution
A saved file has disappeared.	Was the file called up and then printed by touching the [PRINT AND DELETE THE DATA] key?	A file that is printed using the [PRINT AND DELETE THE DATA] key is automatically deleted after being printed. To print a file without deleting it, use the [PRINT AND SAVE THE DATA] key.
A file cannot be deleted.	Is the file's attribute set to [PROTECT]?	A file cannot be deleted when its attribute is set to [PROTECT]. Change the attribute to [SHARING] and then delete the file.
A file's attribute cannot be set to [CONFIDENTIAL].	Is the file in the main or custom folder?	A file in the Quick File folder cannot be set to [CONFIDENTIAL]. Move the file to a different folder or set it to [PROTECT].
A file's attribute cannot be changed to [PROTECT].	Is the file set to [CONFIDENTIAL]?	A file cannot be simultaneously set to [CONFIDENTIAL] and [PROTECT]. If set to [CONFIDENTIAL], use [PROPERTY CHANGE] (page 7-18) to change the attribute to [PROTECT].
A name in the Quick File folder is cut off.	Was the name programmed in the advanced transmission settings?	If the name was programmed in the advanced transmission settings before the file was saved in the Quick File folder, that name will be used. However, if the name is longer than the maximum name length of the Quick File folder (30 characters), the excess characters will be discarded.
Resolution settings are not possible.	Was the file saved at low resolution?	A saved file cannot be transmitted at a resolution higher than the resolution at which it was saved.
A file name cannot be programmed or changed.	Have you entered prohibited characters in the file name?	Certain characters (symbols) cannot be used in file names. See "ENTERING CHARACTERS" (entering numbers and symbols) on page 7-26.
A custom folder name cannot be programmed or changed.	Have you entered prohibited characters in the folder name?	Certain characters (symbols) cannot be used in folder names. See "ENTERING CHARACTERS" (entering numbers and symbols) on page 7-26.
The printing speed of a saved file is slow.	The file was saved using one of the following resolution settings: <ul style="list-style-type: none"> • 200 x 200 dpi resolution. • STANDARD (200 x 100 dpi) or FINE (200 x 200 dpi) 	When a file is saved using one of the resolutions setting at left, the printing speed will be slower than when other resolution settings are used.
Black dots appear when a file that was saved with the document filing function is printed.	Was the file saved at other than the following resolutions? <ul style="list-style-type: none"> • 600 x 600 dpi • 600 x 600 dpi and HALF TONE To check the resolution of the saved file, touch the [DETAIL] key in step 5 on page 7-16.	This problem can be alleviated by setting the resolution to 600x600dpi when saving a file with scan save. The problem can be further alleviated by selecting HALF TONE after setting the resolution to 600x600dpi, as light images will be printed lightly.



CHAPTER 8

SPECIFICATIONS

This chapter contains useful information about the machine.

	Page
SPECIFICATIONS	8-2
LIST OF COMBINATION OF PERIPHERAL DEVICES.....	8-4
INDEX	8-5

SPECIFICATIONS

Type	Console
Print system	Electrophotographic system
Photoconductive type	OPC drum
Developer system	Dry-type two-component magnetic brush development
Fusing system	Heater roller
Resolution	Scan: 600 x 600 dpi, output: 600 x 600 dpi
Gradation	256 levels
Originals	Sheets, bound documents Maximum size: A3 or 11" x 17"
Copy paper	Plain paper and special papers
Copy sizes	Max. A3 or 11" x 17", min. A5R or 5-1/2" x 8-1/2"R, Postcard Image loss: Max 8 mm or 21/64" (leading edge and trailing edge in total), max. 8 mm or 21/64" (along all other edges in total)
Warm-up time	80 seconds or less
First-copy time	4.9 seconds or less*
* Conditions: The document glass is used and A4 size paper is fed horizontally from the machine tray (tray 1).	
Copy ratio	Variable: 25 to 400% in 1% increments, total 376 steps Fixed presets: 25%, 50%, 70%, 81%, 86%, 100%, 115%, 122%, 141%, 200% and 400% for AB system, 25%, 50%, 64%, 77%, 100%, 121%, 129%, 200% and 400% for inch system.
Continuous copy	999 copies
Dimensions (including automatic document feeder)	826 mm (W) x 665 mm (D) x 1127 mm (H) (32-33/64" (W) x 26-11/64" (D) x 44-23/64" (H))
Weight	Approx. 100 kg (Approx. 220.5 lbs.)
Overall dimensions (When tray is extended)	963 mm (W) x 665 mm (D) (37-29/32" (W) x 26-11/64"(D))
Required power supply	For power supply requirements, see the name plate located on the back of the main unit.
Operating conditions	Temperature: 10°C to 30°C (50°F to 86°F) Humidity: 20% to 85%

Automatic document feeder

Name	B/W scanner module/DSPF
Original size	A3 to A5 (11" x 17" to 5-1/2" x 8-1/2")
Weight of originals	50 to 128 g/m ² (14 to 34 lbs.)
Number of originals	Maximum 50 sheets (maximum 30 A3 or B4 (11" x 17" or 8-1/2" x 14") size sheets*), stack height must not exceed the heights indicated below. 50 to 80 g/m ² (14 to 21 lbs.): 6.5 mm (17/64") or less 80 to 128 g/m ² (21 to 34 lbs.): 5 mm (13/64") or less
Power supply	Supplied from machine
Dimensions	824 mm (W) x 606 mm (D) x 190 mm (H) (32-7/16" (W) x 23-55/64" (D) x 7-31/64" (H))
Weight	Approx. 21.0 kg (46.3 lbs.)

* Maximum of 15 sheets when originals are heavier than 105 g/m² (28 lbs.). If the number of placed sheets exceeds this, scanning of the originals will not take place correctly and an extended image may result.

Some discrepancies may exist in the illustrations and content due to improvements to the machine.

Continuous copying speed (when the offset function is not used)

	Olivetti d-Copia 3501 / 3501 MF Olivetti d-Copia 4501 / 4501 MF
Copy paper size	100% / Reduced / Enlarged
A3 (11" x 17")	17 copies/min.
B4 (8-1/2" x 14")	20 copies/min.
A4 (8-1/2" x 11")	35 copies/min.
A4R (8-1/2" x 11"R)	25 copies/min.
B5 (7-1/4" x 10-1/2")	35 copies/min.
B5R (7-1/4" x 10-1/2"R)	25 copies/min.
A5R (8-1/2" x 5-1/2"R)	35 copies/min.

Centre tray specifications

Output method	Face-down output
Maximum number of sheets (80g/m ² (20lbs.) /recommended paper)	400 sheets*
Paper type	Plain paper and special paper

* The maximum number of pages that can be held varies depending on ambient conditions in the installation location, the type of paper, and the storage conditions of the paper.

Acoustic Noise Emission (measurement according to ISO7779)

	Printing mode	Standby mode
Sound power level L_{wA}	6.8B or less	5.0B or less

Emission Concentration (measurement according to RAL-UZ85: Edition Mar. 2002)

Ozone	0.02 mg/m ³ or less
Dust	0.075 mg/m ³ or less
Styrene	0.07 mg/m ³ or less

LIST OF COMBINATION OF PERIPHERAL DEVICES

The table below shows the possible system configurations. Some devices require the installation of others (B) to be functional and some cannot be installed together (A).

		(B)											
		Multi purpose drawer	Stand/3 x 500 sheet paper drawer	Stand/MPD & 2000 sheet	Duplex module/bypass tray	Duplex module	Saddle stitch finisher	Finisher	Mail-bin stacker	Exit tray	Upper exit tray extension	Punch unit	
(A)	Related to paper feed unit												
	Multi purpose drawer	-	X	X			X						X
	Stand/3 x 500 sheet paper drawer	X	-	X									
	Stand/MPD & 2000 sheet paper drawer	X	X	-									
	Duplex module/bypass tray	O ^{*1}			-		X						X
	Duplex module	O ^{*1}				-							
	Output units												
	Saddle stitch finisher	X	O ^{*1}	X	O	-	X	X	X				
	Finisher	O ^{*1}					X	-	X				X
	Mail-bin stacker	O ^{*1}					X	-					
	Exit tray				O ^{*1}	X				-			X
	Upper exit tray extension							X	X		-		
	Punch unit	X	O ^{*1}	X	O	O	X	X	X				-

O = (A) and (B) must be installed together.

O^{*1} = (A) requires installation of one of the (B) units.

X = Cannot be installed together.

INDEX

[✖] key 1-13
[#/P] key 1-13

■ Numerics

1-sided copy
-Automatic document feeder 4-7
-Document glass 4-11
2in1 5-23, 7-12
2-sided copy 1-3, 4-10, 4-13

■ A

ACC.#-C 1-13
[ACC.#-C] key 1-13, 1-18
Acceptable originals 4-2
Account number 1-18
Additional fax memory 1-12
Address control 2-12
Adjusting the exposure 1-3, 4-14
All custom setting list 2-14
Applicable plain paper 2-4
Applicable special media 2-4
Attributes 7-3
Auditing mode 1-18
Auto image 4-15
Auto power shut-off mode 1-8
Automatic copy image rotation 4-4
Automatic document feeder 1-9, 2-22, 4-2
-1-sided copies 4-7
-Acceptable originals 4-2
-Automatic two-sided copying 4-10
-Misfeed original 2-22
-Setting originals 4-3
-User maintenance 6-2
Automatic exposure adjustment 4-14
Automatic selection 4-15
Automatic two-sided copying
-Automatic document feeder 4-10
-Document glass 4-13
Automatic two-sided printing 2-4

■ B

B/W reverse 1-6, 5-2, 5-28
Barcode font kit 1-12
Binding change 4-10, 4-13
Book copy 1-5, 5-2, 5-25
Book original 5-5
Bypass tray 1-9, 2-19, 3-2, 4-20
Bypass tray extension 3-3

■ C

[C] key 1-13, 7-4
[CA] key 1-13, 7-4
Call for service 2-23
[CALL] key 1-16
Calling up and using a file 7-13

Calling up and using a saved file 7-15
-Delete 7-19
-Detail 7-19
-Move 7-19
-Print 7-16
-Property change 7-18
-Send 7-17
Card shot 1-6, 5-2, 5-26, 7-12
Cartridge lock lever 1-10
Centre erase 5-4
Centre tray 1-9, 4-9
[CENTRE TRAY] key 3-18
Changing the paper size in paper tray 2-2
Charger cleaner 6-2
Clear all key 1-13, 7-4
Clear key 1-13, 7-4
Clock 2-12
Confidential 7-3
Contents 0-5 to 0-6
Continuous copying speed 8-3
[COPY] key 1-13
Covers/inserts 1-5, 5-2, 5-11
Creating a custom folder 7-24
Custom folder 7-3, 7-21, 7-24 to 7-25
Custom settings 2-12, 7-21
[CUSTOM SETTINGS] key 1-13, 7-4

■ D

Data security kit 1-12
Date print 1-6, 5-29, 5-32
Default settings 2-14
[DETAIL] key 1-16
Display contrast 2-14
Display switching keys 1-16
Disposal of hole punch scrap 3-21
Document feeder tray 4-2, 4-3
Document filing control 2-12
Document filing function 1-8, 7-1
Document filing user / folder list 2-14
[DOCUMENT FILING] key 1-13, 7-4
Document glass
-1-sided copies 4-11
-Automatic two-sided copying 4-13
-Placing originals 4-3
-User maintenance 6-2
Dual page copy 1-4, 5-2, 5-5
DUAL PAGE SCAN 7-12
Duplex module 1-9, 1-11, 2-19, 3-2
Duplex module/bypass tray 1-11, 3-2
Duplex module side cover 1-10

■ E

Editing and deleting
-Custom folder 7-25
-User names 7-23
[E-MAIL/FTP] key 1-16
Energy saving features 1-8
Energy Star guidelines 1-8
Enlargement 4-15
Entering characters 7-26 to 7-27

Erase 1-4, 5-2, 5-4, 7-12
 Examples of covers and inserts 5-16 to 5-21
 -Covers 5-17 to 5-20
 -Inserts 5-21
 Exit tray 1-9, 1-11, 3-2

F

Facsimile expansion kit 1-12
 Fax data receipt/forward 2-12
 [FAX JOB] key 1-16
 Features 1-3
 [FILE FOLDER] key 7-5
 Finisher 1-11, 3-7
 Finisher compiler 3-11
 Flash ROM kit 1-12
 Front cover 1-9, 3-5, 3-14
 Fusing unit 1-10, 2-17, 2-18
 Fusing unit pressure adjusting levers 2-9

G

General procedure for using special functions 5-2
 Greyed out 1-14
 Group 1-3, 3-8, 3-18, 4-9
 [GROUP] key 3-9, 3-18

H

[HDD STATUS] key 7-5
 Heavy paper 2-3, 2-4
 Highlighted 1-14
 Hole punching 1-8, 3-17

I

Icon 1-14, 5-16, 7-5
 [IMAGE SEND] key 1-13
 Information 2-17
 Installation requirements 0-2
 Interior 1-10
 [INTERNET-FAX] key 1-16
 Interrupting a copy run 1-7, 5-43

J

Job build 1-5, 5-2, 5-8, 7-12
 Job programs 1-6, 5-41 to 5-42
 -Calling up 5-42
 -Deleting 5-42
 -Storing 5-41
 Job status screen 1-15
 [JOB STATUS] key 1-13

K

Key operator programs 2-12
 Keyboard select 2-14

L

Labels 2-3
 Landscape 1-2
 Latch 3-7
 List print 2-14

Loading paper 2-2
 -Bypass tray 3-3
 -Multi purpose drawer 2-8
 -Stand/3 x 500 sheet paper drawer 2-10
 -Stand/MPD & 2000 sheet paper drawer 2-11
 -Tray 1 2-2
 Lower cover 3-2

M

Mail bins 3-5
 Mail-bin stacker 1-11, 3-5
 Main charger 6-2
 Main features 1-3 to 1-8
 Main folder 7-3
 Main screen 5-2
 Manual exposure adjustment 4-14
 Manual selection 4-16
 Margin shift 1-4, 5-2, 5-3
 Meaning of "R" 1-2
 Mirror image 1-6, 5-2, 5-28
 Misfeed 2-17 to 2-22, 3-6, 3-12, 3-22 to 3-23
 Misfeed in the paper feed area 2-20 to 2-21
 Misfeed original 2-22
 Misfeed removal 2-17
 -Automatic document feeder 2-22
 -Bypass tray 2-19
 -Duplex module 2-19
 -Finisher 3-12
 -Saddle stitch finisher 3-22
 -Stand/3 x 500 sheet paper drawer 2-21
 -Transport area, fusing area, and exit area 2-18
 -Tray 1 2-20
 Mode select key 1-15
 Mode select keys 1-13, 7-4
 Multi purpose drawer 1-9, 1-11, 2-3, 2-8
 Multi shot 1-5, 5-2, 5-23

N

Network scanner expansion kit 1-12
 Non-standard sizes 2-3, 2-5, 2-6, 4-5
 Number of pages printed 1-18
 number of pages transmitted (scanned) 1-18
 Numeric keys 1-13, 7-4

O

Offset 1-7, 3-8, 3-15
 [OFFSET] key 3-9, 3-18
 Offset tray 3-7, 3-14
 Operation panel 1-9, 1-13
 -Document filing function 7-4
 Original guides 4-3
 Original orientation 3-16, 4-4
 Original size 4-2, 4-5, 4-6
 Output 3-8, 3-9, 3-16, 3-18, 4-9, 4-12
 Output tray 4-9

P

Page numbering 1-7, 5-29, 5-34 to 5-37
 Pamphlet copy 1-4, 5-2, 5-6
 Paper curled 2-24
 Paper tray 1-9, 2-20
 Paper tray settings 2-5, 2-14
 Part names
 -Duplex module 3-2
 -Exterior 1-9
 -Finisher 3-7
 -Interior 1-10
 -Mail-bin stacker 3-5
 -Operation panel 1-13, 7-4
 -Peripheral devices 1-11
 -Saddle stitch finisher 3-14
 Password 7-8
 Peripheral devices 1-11, 1-12
 Photo 4-14
 Photoconductive drum 1-10, 6-2
 Placing originals 4-3
 Plain paper 2-3 to 2-4
 Portrait 1-2
 Postcards 2-8
 Power 1-17, 2-23
 Power switch 1-9, 1-17
 Preheat mode 1-8
 Preset copy ratios 4-16
 [PRINT JOB] key 1-16
 Print menu 5-29 to 5-40
 -Date 5-32
 -Stamp 5-33
 -Page numbering 5-34
 -Text 5-38
 PRINT mode indicators 1-13
 Printer condition 2-12
 Printer server card 1-12
 Printer test page 2-14
 [PRIORITY] key 1-16
 Proper storage 2-16
 Protect 7-3
 PS3 expansion kit 1-11
 Punch module 3-15
 [PUNCH] key 3-18

Q

Quick File folder 7-3
 [QUICK FILE FOLDER] key 7-5
 [READ-END] key 4-12

R

Reduction 4-15
 Reduction/Enlargement 1-4, 4-15
 Replacing the toner cartridges 2-15
 Right output tray 1-11
 Rotation copying 4-4

S

Saddle stitch 1-7, 3-14, 3-17
 Saddle stitch finisher 1-11, 3-14
 Saddle stitch tray 3-14

[SADDLE STITCH] key 3-18
 Saving a document image file 7-6 to 7-12
 -Filing 7-7 to 7-8
 -Print jobs 7-9
 -Quick file 7-6
 -Scan save 7-10 to 7-11
 [SCAN TO HDD] key 7-5
 [SEARCH] key 7-5
 Searching for a file 7-13 to 7-14
 Selecting a function 1-14
 Selecting the exposure level 4-14
 Selecting the exposure mode 4-14
 Selecting the output tray 4-9
 Sender control 2-12
 Sender control list 2-14
 Sending address list 2-14
 Setting the paper size 2-5 to 2-6
 Setting the paper type 2-5 to 2-7
 Sharing 7-3
 Side cover latch 1-10
 Sort 1-3, 3-8, 3-15, 4-9
 [SORT] key 3-9, 3-18
 Special modes (Copier operation) 5-2
 Special modes (Document filing function) 7-12
 Special paper 2-3 to 2-4
 Special papers 4-20
 Specifications 8-2 to 8-3
 -Duplex module 3-2
 -Finisher 3-7
 -Mail-bin stacker 3-5
 -Punch module 3-15
 -Saddle stitch finisher 3-14
 -Stand/3 x 500 sheet paper drawer 2-10
 -Stand/MPD x 2000 sheet paper drawer 2-11
 Specifications of paper trays 2-3
 Stamp 1-6, 5-29, 5-33
 Stand/3 x 500 sheet paper drawer 1-9, 1-11, 2-3, 2-10
 Stand/MPD & 2000 sheet paper drawer 1-9, 1-11, 2-3, 2-11
 Standard sizes 1-2, 2-4
 Standard sizes in both the inch and AB systems ... 1-2
 Staple box 3-7
 Staple cartridge 3-10, 3-14
 Staple cartridge replacement 3-10, 3-19
 Staple jam removal 3-11, 3-20 to 3-21
 Staple sort 1-7, 3-8, 3-16
 [STAPLE SORT] key 3-9, 3-18
 Stapler compiler 3-14
 Stapler section 3-14
 Stapling positions 3-8, 3-16
 [START] key 1-13
 [STOP/DELETE] key 1-16
 Storage of supplies 2-16

T

Tandem copy 1-5, 5-2, 5-9
 Text 1-7, 4-14, 5-29, 5-38
 Text/photo 4-14
 The machine does not operate 2-23, 6-3
 Toner cartridge 1-10, 2-15
 Top cover 3-5, 3-7, 3-14

Top tray..... 3-5, 3-7
Total count..... 2-14
Total number of originals 4-2
Touch panel..... 1-13, 1-14, 7-4, 7-5
Transparency film 2-3, 2-4, 2-10, 2-16, 4-20, 5-22
Transparency inserts 1-5, 5-2, 5-22
Tray..... 1-9
Troubleshooting
-Copier operation 6-3
-Document filing function..... 7-28
-Duplex module 3-4
-Finisher 3-13
-General information 2-23 to 2-25
-Saddle stitch finisher..... 3-24
Types and sizes of paper 2-3 to 2-4
Types and sizes of paper that can be used..... 2-3

■ **U**

Upper exit tray extension..... 1-9, 1-11
Upper paper output area 1-9
User maintenance 6-2
User name..... 7-21 to 7-23

■ **W**

Warming up..... 2-23

■ **X**

XY Zoom 1-4, 4-18

■ **Z**

Zoom 4-16

This equipment complies with the requirements of Directives 89/336/EEC and 73/23/EEC as amended by 93/68/EEC.

Dieses Gerät entspricht den Anforderungen der EG-Richtlinien 89/336/EWG und 73/23/EWG mit Änderung 93/68/EWG.

Ce matériel répond aux exigences contenues dans les directives 89/336/CEE et 73/23/CEE modifiées par la directive 93/68/CEE.

Dit apparaat voldoet aan de eisen van de richtlijnen 89/336/EEG en 73/23/EEG, gewijzigd door 93/68/EEG.

Dette udstyr overholder kravene i direktiv nr. 89/336/EEC og 73/23/EEC med tillæg nr. 93/68/EEC.

Quest' apparecchio è conforme ai requisiti delle direttive 89/336/EEC e 73/23/EEC, come emendata dalla direttiva 93/68/EEC.

Este equipamento obedece às exigências das directivas 89/336/CEE e 73/23/CEE, na sua versão corrigida pela directiva 93/68/CEE.

Este aparato satisface las exigencias de las Directivas 89/336/CEE y 73/23/CEE, modificadas por medio de la 93/68/CEE.

Denna utrustning uppfyller kraven enligt riktlinjerna 89/336/EEC och 73/23/EEC så som kompletteras av 93/68/EEC.

Dette produktet oppfyller betingelsene i direktivene 89/336/EEC og 73/23/EEC i endringen 93/68/EEC.

Tämä laite täyttää direktiivien 89/336/EEC ja 73/23/EEC vaatimukset, joita on muutettu direktiivillä 93/68/EEC.

Η συσκευή αυτή πληρεί τις πρόνοιες των Οδηγιών 89/336/ΕΟΚ και 73/23/ΕΟΚ του Συμβουλίου όπως έχουν τροποποιηθεί από την Οδηγία 93/68/ΕΟΚ του Συμβουλίου.

Bu cihaz Konsey Direktifi 93/68/EEC tarafından düzeltilen 89/336/EEC ve 73/23/EEC Konsey Direktiflerinin gerekliliklerine uygundur.

Tento přístroj je v souladu s požadavky směrníc rady 89/336/EEC a 73/23/EEC, tak jak byly upraveny směrníci rady 93/68/EEC.

See seade on vastavuses Nõukogu Direktiivis nr 89/336/EEC ja 73/23/EEC esitatud nõuetega, vastavalt Nõukogu Direktiivis nr 93/68/EEC esitatud parandustele.

Ez a készülék megfelel a Tanács által kiadott, 89/336/EGK és 73/23/EGK Irányelveknek és az utóbbi módosító 93/68/EGK Irányelvnek.

Ši ierice atbilst tehniskam prasibam pec 89/336/EEC un 73/23/EEC direktivam papildinats ar direktivu 93/68/EEC.

Šis prietaisas atitinka ES Tarybos direktyvu 89/336/EEC ir 73/23/EEC patikslintos direktyvos 93/68/EEC reikalavimus.

To urządzenie spełnia wymagania dyrektyw 89/336/EEC i 73/23/EEC wraz z poprawkami dyrektywy 93/68/EEC.

Tento prístroj je v súlade s požiadavkami smerníc rady 89/336/EEC a 73/23/EEC tak ako boli upravené smernicou rady 93/68/EEC.

Ta aparat je v skladu z zahtevami Direktivi Sveta 89/336/EEC in 73/23/EEC kot je navedeno v dopolnilu k Direktivi Sveta 93/68/EEC.

The CE mark logo label is affixed on an equipment in case that the directives described in the above sentence are applicable to the product. (This sentence is not applicable in any country where the above directives are not required.)

