

**olivetti**



**USER'S GUIDE**

**d-COLORMF3000**

---

(GB)

Code: 559922en

**PUBLICATION ISSUED BY:**

Olivetti S.p.A.

Gruppo Telecom Italia

Via Jervis, 77 - 10015 Ivrea (ITALY)

www.olivetti.com

**Copyright © 2011, Olivetti**

**All rights reserved**

The mark affixed to the product certifies that the product satisfies the basic quality requirements.



The manufacturer reserves the right to carry out modifications to the product described in this manual at any time and without any notice.



**ENERGY STAR** is a U.S. registered mark.

The ENERGY STAR program is an energy reduction plan introduced by the United States Environmental Protection Agency in response to environmental issues and for the purpose of advancing the development and utilization of more energy efficient office equipment.

---

Your attention is drawn to the following actions which could compromise the conformity attested to above, as well as the characteristics of the product:

- incorrect electrical power supply;
  - incorrect installation, incorrect or improper use or use not in compliance with the warnings provided in the User's Manual supplied with the product;
  - replacement of original components or accessories with others of a type not approved by the manufacturer, or performed by unauthorised personnel.
- 

All rights reserved. No part of this material may be reproduced or transmitted in any form or by any means, electronic or mechanical, including photocopying, recording or by any information storage and retrieval system, without permission in writing from the Publisher.

## Thank You

Thank you for purchasing a d-Color MF3000. You have made an excellent choice. Your d-Color MF3000 is specially designed for optimal performance in Windows, Macintosh and Linux environments.

## Trademarks

Acrobat and the Acrobat logo are registered trademarks or trademarks of Adobe Systems Incorporated in the United States and/or other countries.

Adobe, the Adobe logo and Photoshop are registered trademarks or trademarks of Adobe Systems Incorporated in the United States and/or other countries.

Apple and the Apple logo are registered trademarks or trademarks of Apple, Inc. in the United States and/or other countries.

DIC and the DIC logo are registered trademarks or trademarks of DIC Corporation in the United States and/or other countries.

Ethernet is a registered trademark or trademark of Xerox Corporation in the United States and/or other countries.

IEEE and the IEEE logo are registered trademarks or trademarks of The Institute of Electrical and Electronics Engineers, Inc. in the United States and/or other countries.

Mac and Mac OS are registered trademarks or trademarks of Apple, Inc. in the United States and/or other countries.

NETWARE is a registered trademark or trademark of Novell, Inc. in the United States and/or other countries.

Pentium is registered trademark or trademark of Intel Corporation in the United States and/or other countries.

TOYO is a registered trademark of TOYO INK MFG. CO., LTD. in the United States and/or other countries.

Microsoft, Windows and Windows Vista are registered trademarks or trademarks of Microsoft Corporation in the United States and/or other countries.

All other trademarks and registered trademarks are the property of their respective owners.

## Notice

Olivetti S.p.A. reserves the right to make changes to this guide and to the equipment described herein without notice. Considerable effort has been made to ensure that this guide is free of inaccuracies and omissions. However, Olivetti S.p.A. makes no warranty of any kind including, but not limited to, any implied warranties of merchantability and fitness for a particular purpose with regard to this guide.

Olivetti S.p.A. assumes no responsibility for, or liability for, errors contained in this guide or for incidental, special, or consequential damages arising out of the furnishing of this guide, or the use of this guide in operating the equipment, or in connection with the performance of the equipment when so operated.

# SOFTWARE LICENSE AGREEMENT

This package contains the following materials provided by Olivetti S.p.A.: software included as part of the printing system ("Printing Software"), the digitally-encoded machine-readable outline data encoded in the special format and in the encrypted form ("Font Programs"), other software which runs on a computer system for use in conjunction with the Printing Software ("Host Software"), and related explanatory written materials ("Documentation"). The term "Software" shall be used to describe Printing Software, Font Programs and/or Host Software and also include any upgrades, modified versions, additions, and copies of the Software.

The Software is being licensed to you under the terms of this Agreement.

Olivetti grants to you a non-exclusive sublicense to use the Software and Documentation, provided that you agree to the following:

1. You may use the Software and accompanying Font Programs for imaging to the licensed output device(s), solely for your own internal business purposes.
2. In addition to the license for Font Programs set forth in Section 1 above, you may use Roman Font Programs to reproduce weights, styles, and versions of letters, numerals, characters and symbols ("Typefaces") on the display or monitor for your own internal business purposes.
3. You may make one backup copy of the Host Software, provided your backup copy is not installed or used on any computer. Notwithstanding the above restrictions, you may install the Host Software on any number of computers solely for use with one or more printing systems running the Printing Software.
4. You may assign its rights under this Agreement to an assignee of all of Licensee's right and interest to such Software and Documentation ("Assignee") provided you transfer to Assignee all copies of such Software and Documentation Assignee agrees to be bound by all of the terms and conditions of this Agreement.
5. You agree not to modify, adapt or translate the Software and Documentation.
6. You agree that you will not attempt to alter, disassemble, decrypt, reverse engineer or decompile the Software.
7. Title to and ownership of the Software and Documentation and any reproductions thereof shall remain with Olivetti and its licensor.
8. Trademarks shall be used in accordance with accepted trademark practice, including identification of the trademark owner's name. Trademarks can only be used to identify printed output produced by the Software. Such use of any trademark does not give you any rights of ownership in that trademark.
9. You may not rent, lease, sublicense, lend or transfer versions or copies of the Software Licensee does not use, or Software contained on any unused media, except as part of the permanent transfer of all Software and Documentation as described above.
10. IN NO EVENT WILL OLIVETTI OR ITS LICENSOR BE LIABLE TO YOU FOR ANY CONSEQUENTIAL, INCIDENTAL INDIRECT, PUNITIVE OR SPECIAL DAMAGES, INCLUDING ANY LOST PROFITS OR LOST SAVING, EVEN IF OLIVETTI HAS BEEN ADVISED OF THE POSSIBILITY OF SUCH DAMAGES, OR FOR ANY CLAIM BY ANY THIRD PARTY. OLIVETTI OR ITS LICENSOR DISCLAIMS ALL WARRANTIES WITH REGARD TO THE SOFTWARE, EXPRESS OR IMPLIED, INCLUDING, WITHOUT LIMITATION IMPLIED WARRANTIES OF MERCHANTABILITY, FITNESS FOR A PARTICULAR PURPOSE, TITLE AND NON-INFRINGEMENT OF THIRD PARTY RIGHTS. SOME STATES OR JURISDICTIONS DO NOT ALLOW THE EXCLUSION OR LIMITATION OF INCIDENTAL, CONSEQUENTIAL OR SPECIAL DAMAGES, SO THE ABOVE LIMITATIONS MAY NOT APPLY TO YOU.

11. Notice to Government End Users: The Software is a “commercial item,” as that term is defined at 48 C.F.R.2.101, consisting of “commercial computer software” and “commercial computer software documentation,” as such terms are used in 48 C.F.R. 12.212. Consistent with 48 C.F.R. 12.212 and 48 C.F.R. 227.7202-1 through 227.7202-4, all U.S. Government End Users acquire the Software with only those rights set forth herein.
12. You agree that you will not export the Software in any form in violation of any applicable laws and regulations regarding export control of any countries.

# Legal Restrictions on Copying

Certain types of documents must never be copied with the purpose or intent to pass copies of such documents off as the originals.

The following is not a complete list, but is meant to be used as a guide to responsible copying.

## Financial Instruments

- Personal checks
- Traveler's checks
- Money orders
- Certificates of deposit
- Bonds or other certificates of indebtedness
- Stock certificates

## Legal Documents

- Food stamps
- Postage stamps (canceled or uncanceled)
- Checks or drafts drawn by government agencies
- Internal revenue stamps (canceled or uncanceled)
- Passports
- Immigration papers
- Motor vehicle licenses and titles
- House and property titles and deeds

## General

- Identification cards, badges, or insignias
- Copyrighted works without permission of the copyright owner

In addition, it is prohibited under any circumstances to copy domestic or foreign currencies, or works of art without permission of the copyright owner.

When in doubt about the nature of a document, consult with legal counsel.



*This machine provides the forgery prevention function in order to prevent financial instruments from being copied illegally.*

*We appreciate your understanding that printed images may infrequently have some noise or image data may not be stored under certain circumstances due to this forgery prevention function.*

# ***DIRECTIVE 2002/96/CE ON THE TREATMENT, COLLECTION, RECYCLING AND DISPOSAL OF ELECTRIC AND ELECTRONIC DEVICES AND THEIR COMPONENTS***

## **INFORMATION**

### ***1. FOR COUNTRIES IN THE EUROPEAN UNION (EU)***

The disposal of electric and electronic devices as solid urban waste is strictly prohibited: it must be collected separately.

The dumping of these devices at unequipped and unauthorized places may have hazardous effects on health and the environment.

Offenders will be subjected to the penalties and measures laid down by the law.

#### ***TO DISPOSE OF OUR DEVICES CORRECTLY:***

- a) Contact the Local Authorities, who will give you the practical information you need and the instructions for handling the waste correctly, for example: location and times of the waste collection centres, etc.
- b) When you purchase a new device of ours, give a used device similar to the one purchased to our dealer for disposal.

The crossed dustbin symbol on the device means that:



- when it to be disposed of, the device is to be taken to the equipped waste collection centres and is to be handled separately from urban waste;
- The producer guarantees the activation of the treatment, collection, recycling and disposal procedures in accordance with Directive 2002/96/CE (and subsequent amendments).

### ***2. FOR OTHER COUNTRIES (NOT IN THE EU)***

The treatment, collection, recycling and disposal of electric and electronic devices will be carried out in accordance with the laws in force in the country in question.



---

# Contents

---

<b>1 Introduction .....</b>	<b>1-1</b>
<b>Getting Acquainted with Your Machine .....</b>	<b>1-2</b>
Space Requirements.....	1-2
Part Names .....	1-4
Front View.....	1-4
Rear View .....	1-6
Front View with Options .....	1-6
Adjusting the angle of the control panel.....	1-7
Drivers CD/DVD.....	1-8
Printer Drivers (PostScript Drivers).....	1-8
Printer Drivers (PCL Drivers) .....	1-8
Printer Drivers (XPS Drivers).....	1-8
Printer Drivers (PPD Files).....	1-9
Scanner Drivers .....	1-9
PC Fax Drivers.....	1-9
Applications CD/DVD .....	1-10
Applications.....	1-10
Documentation CD/DVD .....	1-12
Documentation.....	1-12
System Requirements.....	1-13

<b>2</b>	<b>Control panel and touch panel screens</b>	<b>2-1</b>
	<b>About the Control Panel</b>	<b>2-2</b>
	<b>Touch panel screens</b>	<b>2-5</b>
	Home screen	2-5
	Initial Copy mode screen	2-7
	Initial Scan to Folder mode screen	2-8
	Initial Scan to E-mail mode screen	2-9
	Initial Fax mode screen	2-9
	Job screen	2-10
	Status screen	2-11
	USB/HDD screen	2-12
	Keys and icons that appear in the screens	2-13
	<b>User authentication and account track</b>	<b>2-15</b>
	With user authentication	2-15
	Device authentication	2-15
	External server authentication	2-15
	Logging in using the authentication device	2-16
	With account track	2-16
<b>3</b>	<b>Utility Settings</b>	<b>3-1</b>
	<b>[Accessibility]</b>	<b>3-2</b>
	<b>[Meter Count]</b>	<b>3-7</b>
	<b>[Address Registration]</b>	<b>3-8</b>
	<b>[User Settings]</b>	<b>3-10</b>
	[Machine Settings]	3-13
	[Copy Settings]	3-15
	[Scan Settings]	3-16
	[Print Settings]	3-17
	[Fax Settings]	3-20
	[Select Default Start App]	3-20
	<b>[Admin Settings]</b>	<b>3-21</b>
	[Machine Settings]	3-41
	[Administrator Registration]	3-43
	[Address Registration]	3-43
	[Authentication Setting]	3-44
	[Ethernet]	3-45
	[External Memory Print]	3-48
	[Job Timeout]	3-48
	[Copy Settings]	3-48
	[Print Settings]	3-49
	[Fax Settings]	3-63
	[Maintenance Menu]	3-63
	[Folder Settings]	3-69
	[Security Settings]	3-70
	Changing the administrator password	3-74
	Limitations of the password rules	3-74

Passwords regulated by the password rules.....	3-74
Conditions of the password rules.....	3-75
Enhanced security settings.....	3-75
Required settings.....	3-75
Changed settings.....	3-76
[Restore Defaults].....	3-77
[HDD Format].....	3-77
[Paper Empty].....	3-78
[Restriction Code Settings].....	3-78
[Erase Job Log].....	3-78
<b>4 Media Handling .....</b>	<b>4-1</b>
<b>Print Media .....</b>	<b>4-2</b>
Specifications.....	4-2
Types.....	4-4
Plain Paper (Recycled Paper).....	4-4
Thick Stock.....	4-5
Envelope.....	4-6
Label.....	4-7
Letterhead.....	4-8
Postcard.....	4-8
Glossy Media.....	4-9
Single Side Only.....	4-10
Special Paper.....	4-11
Printable Area.....	4-12
Envelopes.....	4-13
Page Margins.....	4-13
<b>Loading Media .....</b>	<b>4-14</b>
How do I load media?.....	4-14
Tray 1 (Manual Feed Tray).....	4-14
Loading Plain Paper, Single Side Only and Special Paper.....	4-14
Other Media.....	4-16
Loading Envelopes.....	4-17
Loading Label Sheets/Letterhead/Postcards/Thick Stock and Glossy Media.....	4-19
Tray 2.....	4-21
Loading Plain Paper, Single Side Only and Special Paper.....	4-21
Loading Label Sheets/Letterhead/Postcards/Thick Stock and Glossy Media.....	4-24
Tray 3/4 (Optional Lower Feeder Unit).....	4-27
Loading Plain Paper, Single Side Only and Special Paper.....	4-27
<b>About Duplex Printing .....</b>	<b>4-30</b>
How do I aut duplex?.....	4-30
<b>Output Tray .....</b>	<b>4-32</b>
<b>Media Storage .....</b>	<b>4-33</b>
<b>Original Media .....</b>	<b>4-34</b>

Specifications .....	4-34
Documents that can be placed on the original glass .....	4-34
Documents that can be loaded into the ADF .....	4-34
<b>Loading a Document .....</b>	<b>4-36</b>
Placing a document on the original glass.....	4-36
Loading a document into the ADF.....	4-37
<b>5 Using the Printer Driver .....</b>	<b>5-1</b>
<b>Selecting Driver Options/Defaults</b>	
<b>(for Windows) .....</b>	<b>5-2</b>
Windows Server 2008 R2/7/Vista/Server 2008/XP/Server 2003/2000 .	5-2
<b>Uninstalling the Printer Driver</b>	
<b>(for Windows) .....</b>	<b>5-4</b>
Windows Server 2008 R2/7/Vista/Server 2008/XP/Server 2003/2000 .	5-4
<b>Displaying Printer Driver Settings</b>	
<b>(for Windows) .....</b>	<b>5-5</b>
Windows 7/Server 2008 R2 .....	5-5
Windows Vista/Server 2008.....	5-5
Windows XP/Server 2003 .....	5-5
Windows 2000 .....	5-5
<b>Using the Postscript, PCL and XPS Printer Driver .....</b>	<b>5-6</b>
Common Buttons .....	5-6
[OK].....	5-6
[Cancel].....	5-6
[Apply].....	5-6
[Help].....	5-6
[Favorite Setting].....	5-6
[Printer View].....	5-7
[Paper View].....	5-7
[Quality View].....	5-7
[Printer Information] .....	5-7
[Default].....	5-7
[Advanced] Tab (PostScript Printer Driver Only).....	5-7
[My Tab] .....	5-8
[Basic] Tab .....	5-8
[Layout] Tab .....	5-9
[Cover Mode] Tab .....	5-9
[Stamp/Composition] Tab.....	5-9
[Quality] Tab.....	5-10
[Other] Tab.....	5-11
Limitations on printer driver functions installed with Point and Print .....	5-11
<b>6 Proof Print, External memory and ID &amp; Print functions .....</b>	<b>6-1</b>
<b>Proof Print .....</b>	<b>6-2</b>
Printing a job saved on the hard disk .....	6-2
Deleting a job saved on the hard disk.....	6-2

<b>External Memory</b> .....	<b>6-3</b>
Printing from a connected USB memory device .....	6-3
Selecting the type of files to be displayed .....	6-4
<b>ID &amp; Print</b> .....	<b>6-4</b>
Printing simultaneously with log-in .....	6-4
Specifying a job to print.....	6-4
Deleting a job .....	6-5
<b>7 Performing Copy mode operations</b> .....	<b>7-1</b>
<b>Basic copy operation</b> .....	<b>7-2</b>
<b>[Original Size]</b> .....	<b>7-4</b>
Documents of mixed page sizes .....	7-4
<b>[Paper]</b> .....	<b>7-5</b>
<b>[Zoom]</b> .....	<b>7-6</b>
<b>[Duplex/Combine]</b> .....	<b>7-7</b>
<b>[Density]</b> .....	<b>7-8</b>
<b>[Original Type]</b> .....	<b>7-9</b>
<b>[Color Mode]</b> .....	<b>7-9</b>
<b>[Finishing]</b> .....	<b>7-10</b>
<b>[Proof Copy]</b> .....	<b>7-10</b>
Proof Copy operation .....	7-10
<b>[Separate Scan]</b> .....	<b>7-11</b>
Scanning the document in separate batches .....	7-12
<b>[ID Copy]</b> .....	<b>7-13</b>
<b>[Paper Margin]</b> .....	<b>7-14</b>
<b>[Image Quality]</b> .....	<b>7-15</b>
<b>8 Additional copy operations</b> .....	<b>8-1</b>
<b>Interrupting a copy job</b> .....	<b>8-2</b>
<b>Copy programs</b> .....	<b>8-3</b>
Storing a copy program.....	8-3
Deleting a copy program .....	8-3
Copying using stored settings (copy programs).....	8-4
<b>9 Scanning From a Computer Application</b> .....	<b>9-1</b>
<b>Basic Scanning Operation</b> .....	<b>9-2</b>
<b>Windows TWAIN Driver Settings</b> .....	<b>9-3</b>
Mode settings.....	9-3
When [Basic Mode] is selected.....	9-3
When [Advanced Mode] is selected.....	9-4
<b>Windows WIA Driver Settings</b> .....	<b>9-7</b>
<b>Macintosh TWAIN Driver Settings</b> .....	<b>9-8</b>
Mode settings.....	9-8
When [Basic Mode] is selected.....	9-8
When [Advanced Mode] is selected.....	9-9
<b>Using a Web Service</b> .....	<b>9-12</b>

Settings required to use a Web Service.....	9-12
Installing this machine on the computer.....	9-12
Confirmation before installation .....	9-12
Installation procedure.....	9-12
Specifying the scan command from a computer (Web Service) .....	9-13
Specifying the scan command from a computer.....	9-13
<b>10 Scanning with the machine .....</b>	<b>10-1</b>
<b>Initial settings .....</b>	<b>10-2</b>
<b>Useful functions .....</b>	<b>10-2</b>
<b>Performing Scan to E-mail mode operations .....</b>	<b>10-3</b>
Basic Scan to E-mail operation.....	10-3
Specifying document settings .....	10-4
[Simplex/Duplex].....	10-4
[Original Size].....	10-5
[Original Settings] - [Separate Scan].....	10-5
[Original Settings] - [Original Direction].....	10-6
[Original Settings] - [Orig. Binding Position].....	10-6
[Color Mode] .....	10-7
[Original Type].....	10-7
Specifying scan settings.....	10-8
[Background/Density].....	10-8
[Resolution].....	10-8
[File Settings] - [File Type].....	10-9
[File Settings] - [Scan Setting].....	10-9
[File Settings] - [PDF Encrypt].....	10-10
Specifying communication settings.....	10-12
[Binary Division] .....	10-12
[E-mail Encryption].....	10-12
[Send Use Signature].....	10-12
[E-mail].....	10-13
<b>Specifying destinations .....</b>	<b>10-14</b>
Selecting from registered destinations .....	10-14
Selecting from the Favorites list.....	10-14
Selecting with an index search .....	10-15
Selecting by searching for a destination type or name .....	10-15
Directly typing in the address .....	10-16
Selecting from the log .....	10-16
Selecting a program destination.....	10-17
<b>Performing Scan to Folder mode operations .....</b>	<b>10-18</b>
Basic Scan to Folder operation .....	10-18
Specifying document settings .....	10-20
[Simplex/Duplex].....	10-20
[Original Size].....	10-20
[Original Settings] - [Separate Scan].....	10-21
[Original Settings] - [Original Direction].....	10-21

[Original Settings] - [Orig. Binding Position].....	10-22
[Color Mode] .....	10-22
[Original Type].....	10-23
Specifying scan settings.....	10-23
[Background/Density].....	10-23
[Resolution] .....	10-24
[File Settings] - [File Type] .....	10-24
[File Settings] - [Scan Setting].....	10-25
[File Settings] - [PDF Encrypt].....	10-25
Specifying the document name.....	10-26
Specifying communication settings .....	10-27
[URL Notification].....	10-27
[URL Notification Destination].....	10-27
<b>Specifying destinations .....</b>	<b>10-27</b>
Selecting from registered destinations .....	10-27
Selecting from the Favorites list.....	10-28
Selecting with an index search .....	10-28
Selecting by searching for a destination type or name .....	10-28
Directly typing in the address .....	10-29
With [FTP].....	10-29
With [PC(SMB)].....	10-29
With [WebDAV].....	10-30
With [USB Memory] .....	10-30
With [HDD].....	10-31
With [Web Service Settings] .....	10-32
Selecting from the log .....	10-32
Selecting a program destination.....	10-33
<b>Registering destinations .....</b>	<b>10-34</b>
Destination registration .....	10-34
Address Book.....	10-34
Group .....	10-34
Program .....	10-34
Registering an address book destination .....	10-35
Registering an address book destination (E-mail transmission) .....	10-35
Registering Address Book (SMB transmission) .....	10-36
Registering a program destination .....	10-37
<b>11 Replacing Consumables .....</b>	<b>11-1</b>
<b>Replacing Consumables .....</b>	<b>11-2</b>
About Toner Cartridges.....	11-2
Replacing a Toner Cartridge .....	11-4
Replacing a Imaging Unit.....	11-9
Replacing the Waste Toner Bottle .....	11-17
Replacing the Transfer Roller .....	11-20
Replacing the Transfer Belt Unit .....	11-22
Replacing the Backup Battery.....	11-30

Replacing the Fuser Unit.....	11-33
<b>Antistatic Protection .....</b>	<b>11-38</b>
<b>12 Maintenance .....</b>	<b>12-1</b>
<b>Maintaining the machine .....</b>	<b>12-2</b>
<b>Cleaning the machine .....</b>	<b>12-4</b>
Exterior.....	12-4
Media Rollers .....	12-5
Cleaning the Media Feed Rollers (Manual Feed Tray) .....	12-5
Cleaning the Media Feed Rollers for Tray 2/3/4 .....	12-7
Cleaning the Media Transfer Rollers for Tray 3/4 .....	12-8
Cleaning the Media Feed Rollers for the ADF .....	12-9
Cleaning the Laser Lens .....	12-10
<b>13 Troubleshooting .....</b>	<b>13-1</b>
<b>Introduction .....</b>	<b>13-2</b>
<b>Printing a configuration page .....</b>	<b>13-2</b>
<b>Unlocking the Scanner .....</b>	<b>13-3</b>
<b>Preventing Media Misfeeds .....</b>	<b>13-4</b>
<b>Understanding the Media Path .....</b>	<b>13-5</b>
<b>Clearing Media Misfeeds .....</b>	<b>13-6</b>
Media misfeed indications.....	13-6
Clearing a Media Misfeed in Tray 2 .....	13-7
Clearing a Media Misfeed in Tray 3/4 .....	13-11
Clearing a Media Misfeed from the ADF.....	13-13
Clearing a Media Misfeed from the Duplex.....	13-15
Clearing a Media Misfeed from the Fuser Unit .....	13-16
Clearing a Media Misfeed from Tray 1 (Manual Feed Tray) and Transfer Roller.....	13-20
<b>Solving Problems with Media Misfeeds .....</b>	<b>13-23</b>
<b>Solving Other Problems .....</b>	<b>13-26</b>
<b>Solving Problems with Printing Quality .....</b>	<b>13-31</b>
<b>Status, error and service messages .....</b>	<b>13-38</b>
Status messages.....	13-38
Error messages.....	13-39
Warning messages .....	13-39
Operator messages .....	13-41
Service messages.....	13-47
<b>14 Installing Accessories .....</b>	<b>14-1</b>
<b>Introduction .....</b>	<b>14-2</b>
<b>Lower Feeder Unit PF-P08 .....</b>	<b>14-3</b>
Kit Contents.....	14-3
Installing a Lower Feeder Unit PF-P08 .....	14-4
<b>Working Table WT-P01 .....</b>	<b>14-6</b>
Kit Contents.....	14-6



Installing a Working Table WT-P01.....	14-7
<b>15 Authentication device (IC card type) .....</b>	<b>15-1</b>
<b>Using authentication device (IC card type) .....</b>	<b>15-2</b>
<b>Configuring this machine .....</b>	<b>15-2</b>
<b>Registering a user .....</b>	<b>15-3</b>
Registering a user using Data Administrator.....	15-3
Checking the version of the installed Data Administrator.....	15-3
Setup.....	15-3
User registration.....	15-4
Associating the user with card using authentication device .....	15-6
<b>Logging in to this machine .....</b>	<b>15-6</b>
When [Card Authentication] is enabled.....	15-7
When [Card Authentication + Password] is enabled .....	15-7
<b>A Appendix .....</b>	<b>A-1</b>
<b>Technical specifications .....</b>	<b>A-2</b>
Consumable Life Expectancy Chart.....	A-6
User-Replaceable .....	A-6
Service-Replaceable .....	A-7
<b>Text input .....</b>	<b>A-8</b>
Entering text .....	A-8
<b>Our Concern for Environmental Protection .....</b>	<b>A-9</b>
What is an ENERGY STAR product? .....	A-9



# *Introduction* **1**



# Getting Acquainted with Your Machine

## Space Requirements

To ensure easy operation, consumable replacement and maintenance, adhere to the recommended space requirements detailed below.

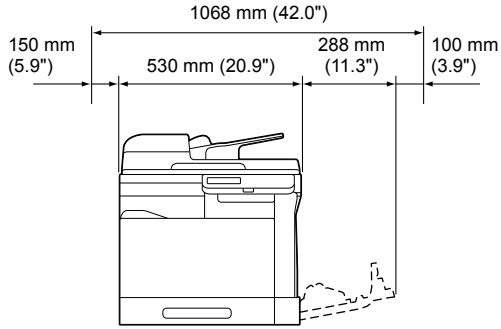

Front View

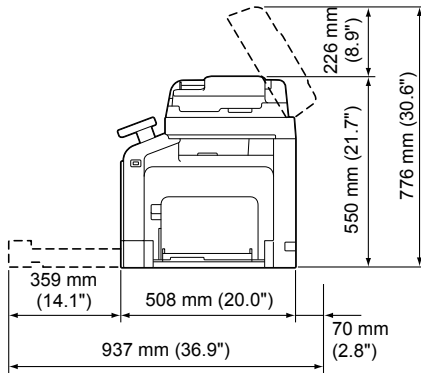

Side View

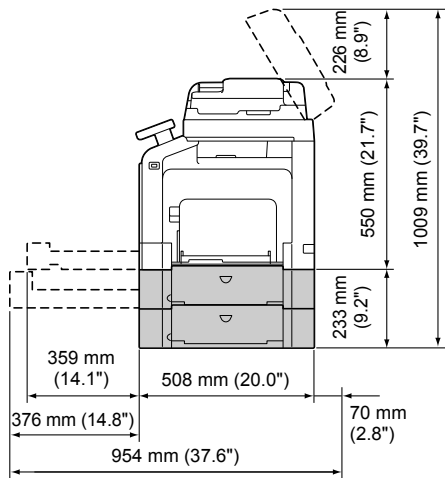

Side View with Options



*The option appears shaded in the above illustrations.*

## Part Names

The following drawings illustrate the parts of your machine referred to throughout this guide, so please take some time to become familiar with them.

### Front View

- 1—Control panel
- 2—Automatic Document Feeder (ADF)
  - 2-a: ADF feed cover
  - 2-b: Document guide
  - 2-c: Document feed tray
  - 2-d: Document output tray
  - 2-e: Document stopper



*Lower the document stopper when scanning Legal-size paper with the ADF.*

- 3—USB HOST port



*A USB hub can be connected to the USB HOST port. In addition, a USB memory device and an authentication device (IC card type) can be connected to the USB hub at the same time.*

- 4—Tray 1 (Manual feed tray)
- 5—Tray 2
- 6—Output tray
- 7—Scanner lock lever
- 8—Original glass
- 9—Original cover pad
- 10—Scanner unit

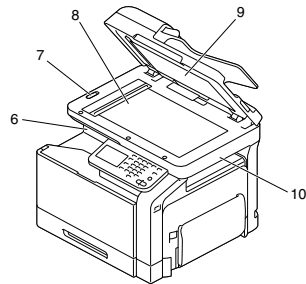
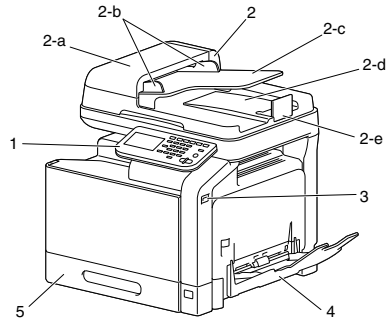

- 11—Fuser unit
- 12—Right door
- 13—Transfer roller
- 14—Transfer belt unit
- 15—Imaging unit(s)
- 16—Front cover
- 17—Waste toner bottle
- 18—Toner cartridge(s)

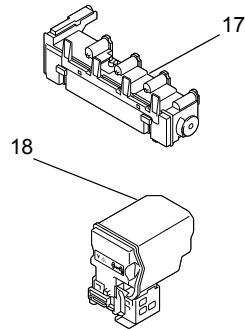
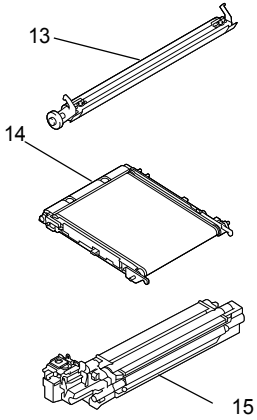
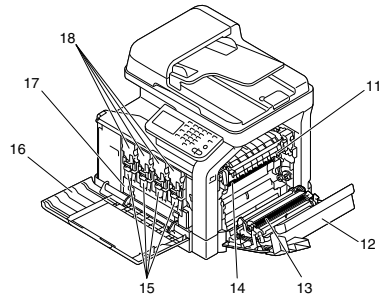

## Rear View

- 1—Power switch
- 2—Rear cover
- 3—Power connection
- 4—LINE (telephone line) jack
- 5—TEL (telephone) jack
- 6—10Base-T/100Base-TX/  
1000Base-T Ethernet Inter-  
face port
- 7—USB port

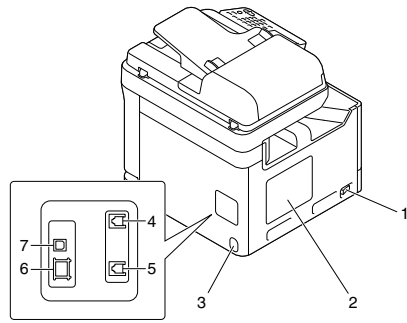

## Front View with Options

- 1—Lower feeder unit PF-P08  
(Tray 3)
- 2—Lower feeder unit PF-P08  
(Tray 4)
- 3—Working Table WT-P01

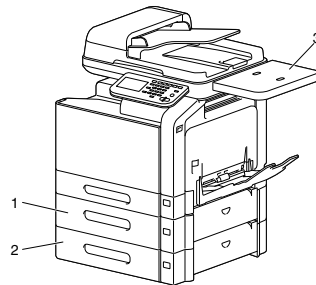



## Adjusting the angle of the control panel

The control panel can be adjusted to any of three angles. Adjust the control panel to the angle that allows for easy operation.

- 1 Grab the sides of the control panel, and then tilt it up.



*Before moving the control panel to a lower angle, tilt it up first, and then slowly tilt it down.*

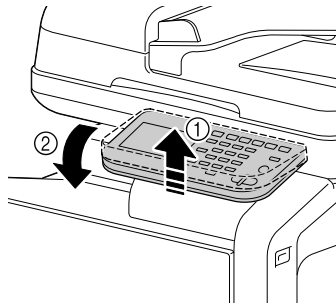
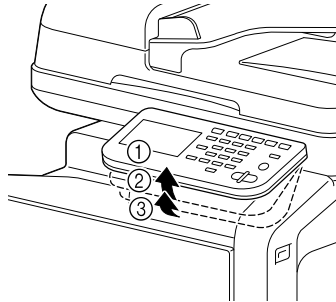

*When tilting the control panel, do not press on the touch panel.*

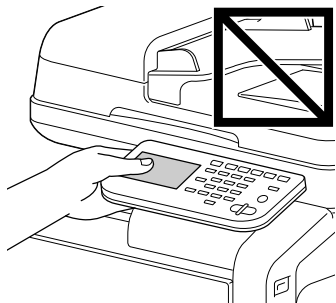

## Drivers CD/DVD

### Printer Drivers (PostScript Drivers)

Operating System	Use/Benefit
Windows 7/Vista/Server 2008/XP/Server 2003/2000	These drivers give you access to all of the printer features, including finishing and advanced layout. For details, refer to “Displaying Printer Driver Settings (for Windows)” on page 5-5.
Windows Server 2008 R2/7/Vista/Server 2008/XP/Server 2003 for 64bit	



*A specific PPD file has been prepared for applications (such as Page Maker and Corel Draw) that require that a PPD file be specified when printing.*

*When specifying a PPD file while printing on Windows Server 2008 R2, Windows 7, Vista, Server 2008, XP, Server 2003 and 2000, use the specific PPD file provided on the Drivers CD/DVD.*

### Printer Drivers (PCL Drivers)

Operating System	Use/Benefit
Windows 7/Vista/Server 2008/XP/Server 2003/2000	These drivers give you access to all of the printer features, including finishing and advanced layout. For details, refer to “Displaying Printer Driver Settings (for Windows)” on page 5-5.
Windows Server 2008 R2/7/ Vista/Server 2008/XP/Server 2003 for 64bit	

### Printer Drivers (XPS Drivers)

Operating System	Use/Benefit
Windows 7/Vista/Server 2008	These drivers give you access to all of the printer features, including finishing and advanced layout.  For details on the installation method and functions, refer to the [Reference Guide] on the Documentation CD/DVD.
Windows Server 2008 R2/7/ Vista/Server 2008 for 64bit	

## Printer Drivers (PPD Files)

Operating System	Use/Benefit
Mac OS X (10.2.8/10.3/10.4/10.5/10.6)	These files are required in order to use the printer driver for each operating system.  For details of the Macintosh and Linux printer driver, refer to the [Reference Guide] on the Documentation CD/DVD.
Red Hat Enterprise Linux 5 Desktop SUSE Linux Enterprise Desktop 10	

## Scanner Drivers

Operating System	Use/Benefit
TWAIN Driver for Windows 7/Vista/Server 2008/XP/Server 2003/2000	These drivers enable you to set scanning functions, such as the color setting and size adjustments.  For details, refer to “Windows WIA Driver Settings” on page 9-7.
TWAIN Driver for Mac OS X (10.3.9/10.4/10.5/10.6)	
WIA Driver for Windows 7/Vista/Server 2008/XP	This driver enables you to set scanning functions, such as the color setting and size adjustments.  For details, refer to “Windows WIA Driver Settings” on page 9-7.
WIA Driver for Windows 7/Vista/Server 2008/XP for 64bit	

## PC Fax Drivers

Operating System	Use/Benefit
Windows 7/Vista/Server 2008/XP/Server 2003/2000	These drivers enable you to specify fax settings, such as the paper settings for sending faxes and the settings for editing the address book. For details, refer to the [Facsimile User's Guide] on the Documentation CD/DVD.
Windows Server 2008 R2/7/Vista/Server 2008/XP/Server 2003 for 64 bit	



*For details on the installation of the drivers, refer to the [Installation Guide] on the Documentation CD/DVD.*



*For details of the Macintosh and Linux drivers, refer to the Reference Guide on the Documentation CD/DVD.*



*Windows TWAIN driver does not correspond to 64-bit applications though it corresponds to 32-bit applications on 64-bit OS.*

## Applications CD/DVD

### Applications

Applications	Use/Benefit
Download Manager (Windows Server 2008 R2/7/Vista/ Server 2008/XP/Server 2003/2000, Mac OS 10.2.8/10.3/10.4/10.5/10.6)	This utility enables fonts and overlay data to be downloaded to the hard disk.  For details, refer to the online help for all functions of Download Manager.
Net Care Device Manager	Printer management functions such as status monitoring and network settings can be accessed.  For details, refer to the Net Care Device Manager User's Guide on the Applications CD/DVD.
Data Administrator	Data Administrator is an administration tool with which authentication data and addresses registered with the control panel of supported devices (multifunctional OA equipment) can be changed from other computers on the network.  For details, refer to the Data Administrator User Manual on the Applications CD/DVD.
Print Status Notifier	This application notifies the user as to whether a print job has completed successfully or has encountered an error.  For details, refer to the Print Status Notifier User's Guide on the Applications CD/DVD.

Direct Print	<p>This application provides functions for sending PDF and TIFF files directly to a printer to be printed.</p> <p>For details, refer to the Direct Print User's Guide on the Applications CD/DVD.</p>
Enterprise Suite Plug-In	<p>This plug-in provides the additional functions of Enterprise Suite, which enables centralized management of devices and permission management.</p>

# Documentation CD/DVD

## Documentation

<b>Documentation</b>	<b>Use/Benefit</b>
Installation Guide	This manual provides installation details that must be performed in order to use this machine, such as setting up the machine and installing the drivers.
Printer/Copier/Scanner User's Guide (this manual)	This manual provides details on general daily operations, such as using the drivers and control panel and replacing consumables.
Facsimile User's Guide	This manual provides details on general fax operations, such as sending and receiving faxes and using the control panel.
Reference Guide	This manual provides details on installing the Macintosh and Linux drivers and on specifying settings for the network.
Quick Guide	This manual provides an introduction to, and illustrations for, basic machine operations and frequently used functions.

# System Requirements

- Personal computer
  - Pentium 3: 400MHz or higher (Windows Vista: 1GHz or higher)
  - PowerPC G3 or later (G4 or later is recommended)
  - Macintosh equipped with an Intel processor
- Operating System
  - Microsoft Windows 7 Home Basic/Home Premium/Professional/Enterprise/Ultimate, Windows 7 Home Premium/Professional/Enterprise/Ultimate, Windows Server 2008 R2 Standard/Enterprise, Windows Server 2008 Standard/Enterprise, Windows Server 2008 Standard/Enterprise x64 Edition, Windows Vista Home Basic/Home Premium/Ultimate/Business/Enterprise, Windows Vista Home Basic/Home Premium /Ultimate/Business /Enterprise x64 Edition, Windows XP Home Edition/Professional (Service Pack 2 or later), Windows XP Professional x64 Edition, Windows Server 2003, Windows Server 2003 x64 Edition, Windows 2000 (Service Pack 4 or later)
  - Mac OS X (10.2.8/10.3/10.4/10.5/10.6; We recommend installing the most recent patch.)
  - Red Hat Enterprise Linux 5 Desktop, SUSE Linux Enterprise Desktop 10
- Free hard disk space  
256 MB or more
- RAM  
512 MB or more
- CD/DVD drive
- I/O interface
  - 10Base-T/100Base-TX/1000Base-T Ethernet interface port
  - USB 2.0 High-Speed compliant port



*The Ethernet cable and USB cable are not included with the machine.*



*For details of the Macintosh and Linux drivers, refer to the [Reference Guide] on the Documentation CD/DVD.*





*Control panel  
and touch panel  
screens* **2**



# About the Control Panel

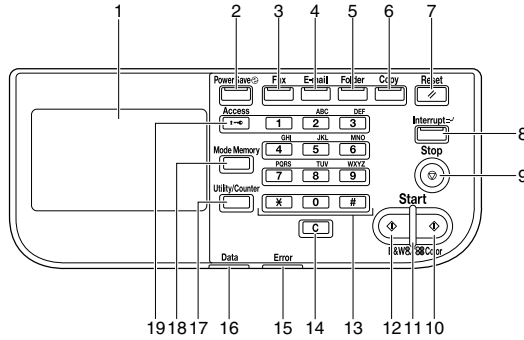

No.	Name	Function
1	Touch panel	Displays various screens and messages. Specify the various settings by directly touching the panel.
2	[Power Save] key/indicator	Press to enter Power Save mode. While the machine is in Power Save mode, the indicator on the [Power Save] key lights up in green and the touch panel goes off. To cancel Power Save mode, press the [Power Save] key again.
3	[Fax] key/indicator	Press to enter Fax mode. While the machine is in Fax mode, the indicator on the [Fax] key lights up in green.
4	[E-mail] key/indicator	Press to enter Scan to E-mail mode. While the machine is in Scan to E-mail mode, the indicator on the [E-mail] key lights up in green.
5	[Folder] key/indicator	Press to enter Scan to Folder mode. While the machine is in Scan to Folder mode, the indicator on the [Folder] key lights up in green.
6	[Copy] key/indicator	Press to enter Copy mode. While the machine is in Copy mode, the indicator on the [Copy] key lights up in green.
7	[Reset] key	Press to clear the settings (except programmed settings) of all displayed functions.  Press to delete a job stopped during the scan operation.

No.	Name	Function
8	[Interrupt] key/ indicator	Press to enter Interrupt mode. While the machine is in Interrupt mode, the indicator on the [Interrupt] key lights up in green. To cancel Interrupt mode, press the [Interrupt] key again.
9	[Stop] key	Pressing the [Stop] key while copying, scanning or printing temporarily stops the operation.
10	[Start (Color) ] key	Press to start color copying, scanning or faxing.  Press to continue interrupted printing.
11	[Start] indicator	Lights up in blue when copying, scanning or faxing can be performed.  Lights up in orange when copying, scanning or faxing cannot be performed.
12	[Start (B&W) ] key	Press to start black-and-white copying, scanning or faxing.  Press to continue interrupted printing.
13	Keypad	Use to enter the number of copies, a fax number, an E-mail address or a name.  Use to type in the various settings.
14	[C] (clear) key	Press to erase numbers or text.  Press to delete a job stopped during the scan operation.
15	[Error] indicator	Flashes in orange if an error occurred.  Lights up in orange when the service representative is being called.
16	[Data] indicator	Flashes in blue while a print job is being received.  Lights up in blue while printing or when a print job is queued.
17	[Utility/Counter] key	Press to display the [Utility Settings] screen.  From the [Utility Settings] screen, settings can be specified for the parameters in the [Accessibility], [Meter Count], [Address Registration], [User Settings] and [Admin Settings] screens.

No.	Name	Function
18	[Mode Memory] key	Press to store the desired settings for copy, fax or scan operations. In addition, stored settings can be recalled.
19	[Access] key	If user authentication or account track settings have been applied, press the [Access] key after entering the user name and password (for user authentication) or the account name and password (for account track) in order to log on to this machine.  While logged on, press the [Access] key to log off.

# Touch panel screens

## Home screen

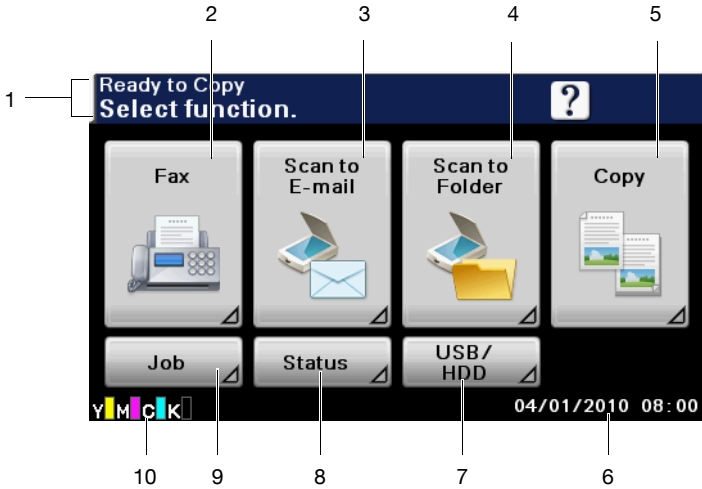

No.	Indication	Description
1	Status	Displays messages about the current operating status.
2	[Fax]	Press to enter Fax mode. For details, refer to the [Facsimile User's Guide].
3	[Scan to E-mail]	Press to enter Scan to E-mail mode. For details on the Scan to E-mail mode operations, refer to "Performing Scan to E-mail mode operations" on page 10-3.
4	[Scan to Folder]	Press to enter Scan to Folder mode. For details on the Scan to Folder mode operations, refer to "Performing Scan to Folder mode operations" on page 10-18.
5	[Copy]	Press to enter Copy mode. For details on the Copy mode operations, refer to "Performing Copy mode operations" on page 7-1.
6	Date/time	Shows the current date and time.

<b>No.</b>	<b>Indication</b>	<b>Description</b>
7	[USB/HDD]	Press to print files on a USB memory device. Press to print a print job saved on hard disk.
8	[Status]	Press to view information on consumables and devices.
9	[Job]	Press to check a print, transmission, reception or stored data job.
10	Toner supply indicators	Shows the amount of toner remaining for yellow (Y), magenta (M), cyan (C) and black (K).

## Initial Copy mode screen

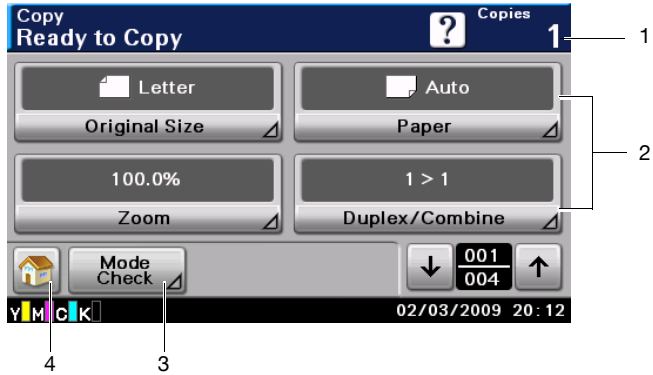

No.	Indication	Description
1	Number of copies	Indicates the specified number of copies.
2	Copy mode operations	Press to display the corresponding screen for specifying various settings.
3	[Mode Check]	Press to check the currently specified copy settings.
4		Press to return to the home screen.

## Initial Scan to Folder mode screen

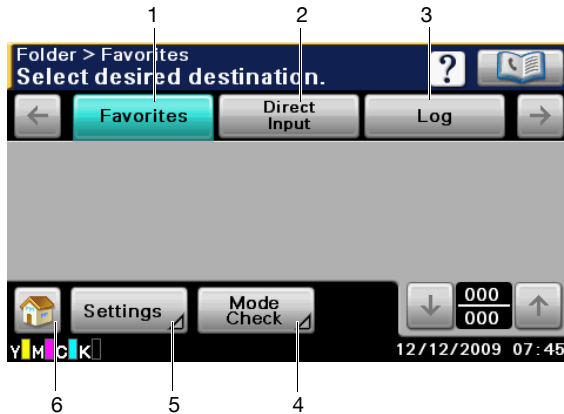

No.	Indication	Description
1	[Favorites]	Press to display frequently used destinations.
2	[Direct Input]	Press to directly enter an address of the selected destination type.
3	[Log]	Press to specify a destination from the log.
4	[Mode Check]	Press to check the currently specified Scan to Folder mode settings.
5	[Settings]	Press to specify settings such as the document scanning method.
6		Press to return to the home screen.



## Initial Scan to E-mail mode screen

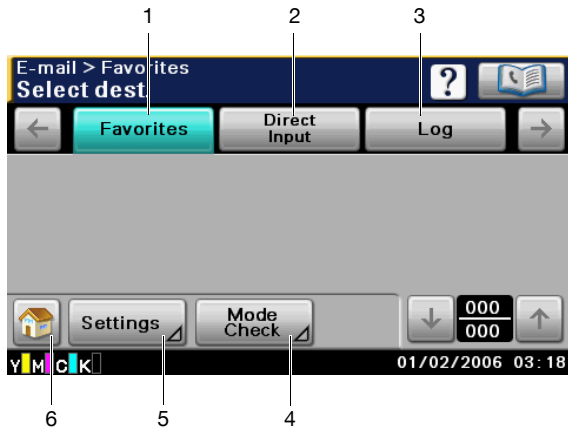



No.	Indication	Description
1	[Favorites]	Press to display frequently used destinations.
2	[Direct Input]	Press to directly enter a destination address.
3	[Log]	Press to specify a destination from the log.
4	[Mode Check]	Press to check the currently specified Scan to E-mail mode settings.
5	[Settings]	Press to specify settings such as the document scanning method.
6		Press to return to the home screen.

## Initial Fax mode screen

For details on the initial Fax mode screen, refer to the [Facsimile User's Guide].

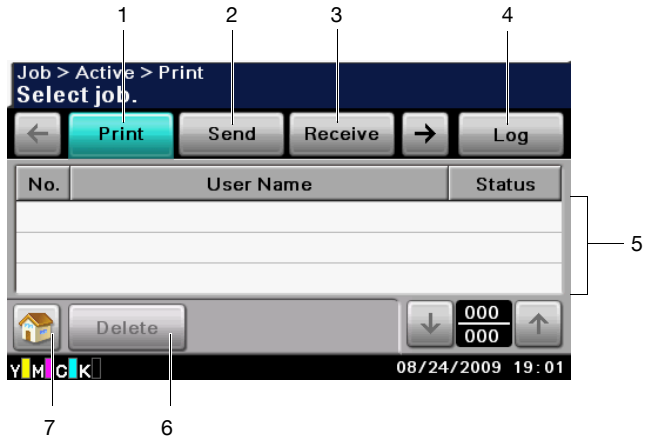

## Job screen

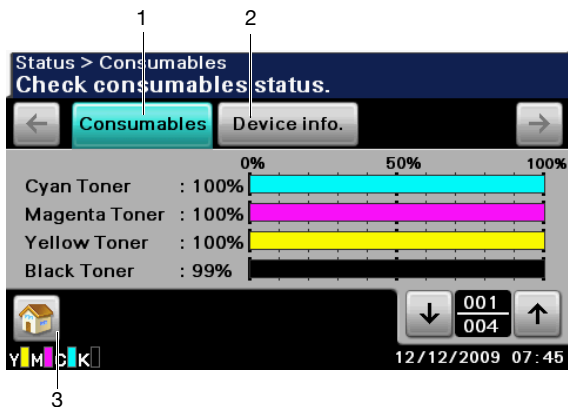

No.	Indication	Description
1	[Print]	Press to display a screen listing the print jobs.
2	[Send]	Press to display a screen listing the transmission jobs.
3	[Receive]	Press to display a screen listing the reception jobs.
4	[Active]/[Log]	Press to display screens listing the jobs currently being performed or the job log.
5	Job list	Displays the list of jobs. The job number, user name and job status can be checked.
6	[Delete]	Press to delete the selected job. Next, press [Yes], then [OK].  <i>When the job log is displayed, [Details] appears. To view job details, press [Details].</i>
7		Press to return to the home screen.

## Status screen



No.	Indication	Description
1	[Consumables]	<p>Press to display a screen showing the status of consumables.</p> <p> <i>The percentages remaining for the consumables may be different from the actual amounts and should be used only as reference.</i></p>
2	[Device info.]	Press to display a screen showing the information of devices.
3		Press to return to the home screen.

## USB/HDD screen

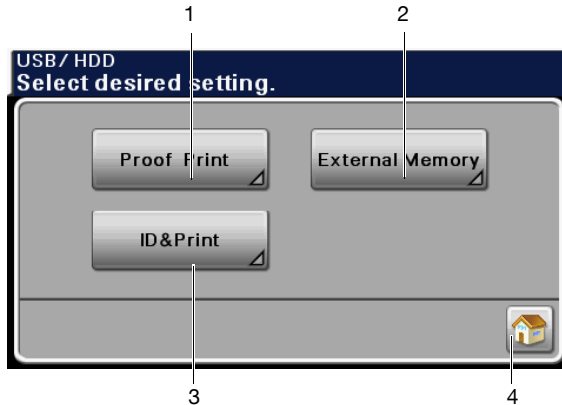

No.	Indication	Description
1	[Proof Print]	Press to print a print job saved on hard disk.
	[User Name]	Select a user.
2	[External Memory]	Press to print files on a USB memory device.
	[File List]	Select the file to be printed. In addition, print settings can be specified.
	[File Type]	Select the type of files to be displayed.
3	[ID & Print]	Press to print a print job sent as a registered user or public user.
	[Login User]	Press to display and print a job of the user who is currently logged in.
	[Public User]	Press to display and print a job of a public user.
4		Press to return to the home screen.



For details on the Proof Print function, refer to "Proof Print" on page 6-2.

























For details on the External Memory Print function, refer to "External Memory" on page 6-3.



For details on the ID & Print function, refer to "ID & Print" on page 6-4.

## Keys and icons that appear in the screens

Icon	Description
 	<p>If the screen has multiple pages, press [↑] or [↓] to select a different page.</p> <p>If values appear between [↑] and [↓], the current page number/total number of pages is indicated.</p>
 	<p>If there are tabs that are not displayed, press [←] or [→] to select a different tab.</p>
 	<p>Press to adjust the image quality during a copy, scan or fax operation.</p>
 	<p>Press [+] or [-] to change the entered value.</p>
	<p>Press to view the error message when an error occurs.</p>
	<p>Press to display descriptions of the various functions. A description of the current screen will be displayed.</p>
	<p>Press to display the address book. From this screen, you can select single destinations and group destinations registered in the address book.</p>
	<p>Press to return to the home screen.</p>
	<p>Appears while scanning and printing when making copies.</p>
	<p>Appears while scanning with fax transmission and scanning operations.</p>

Icon	Description
	Appears while printing with PC printing, received fax printing and report printing.
	Appears when using a G3 fax connection.
	Appears when there are documents queued for a timer transmission.
	Appears when there are fax documents received with memory reception or PC faxing.
	Appears when data or documents are being sent from this unit.
	Appears when this unit is receiving data or documents.
	Appears when enhanced security settings have been applied.
	Appears when a USB memory device is connected.

# User authentication and account track

If user authentication or account track settings have been specified on the machine, the user name or account name and the password must be entered in the Login screen in order to log on.

The following procedures describe how to log on when user authentication or account track settings have been specified.



*User authentication and account track settings are specified from Web Connection. For details, refer to the [Reference Guide].*

## With user authentication

### Device authentication

- 1 Specify a name and password for [User Name] and [Password].
  - For [User Name], the name can be specified either by directly typing it in or selecting from a list.
- 2 Press [Login].

If authentication was successful, the functions of this machine can be used.

### External server authentication

- 1 Specify a name and password for [User Name] and [Password].
  - For [User Name], the name can be specified either by directly typing it in or selecting from a list.
- 2 Specify a server for [Server].
- 3 Press [Login].

If authentication was successful, the functions of this machine can be used.



*If account track settings have been applied, account track will be performed after [Login] is pressed. However, if the machine has been set to synchronize user authentication and account track and an account had been specified for the user who is logging on, account track will not be performed. For details, refer to the [Reference Guide].*

## Logging in using the authentication device

The following describes how to log in to this machine with IC card authentication.

- To perform IC card authentication, register the information recorded in the IC card in advance.
- If an authentication failure recurs, the problem may be due to incorrect registration of IC card information. Register IC card information again.
- Press [Device Authentication] to log in by specifying the user name and password for [User Name] and [Password], without using the authentication device.

**1** Press [Card Authentication].

**2** Press [Access Basic Screen].

- For ID & Print jobs, press [Begin Printing] to authenticate the user and start printing.

**3** Place the IC card on the authentication device.



*For details on how to register an IC card for the user, refer to “Authentication device (IC card type)” on page 15-1.*

## With account track

**1** Specify an account and password for [Account] and [Password].

**2** Press [Login].

If authentication was successful, the functions of this machine can be used.



# *Utility Settings* **3**



# [Accessibility]

From the [Accessibility] screen, various settings can be specified for the displayed screens and the operation of control panel keys.

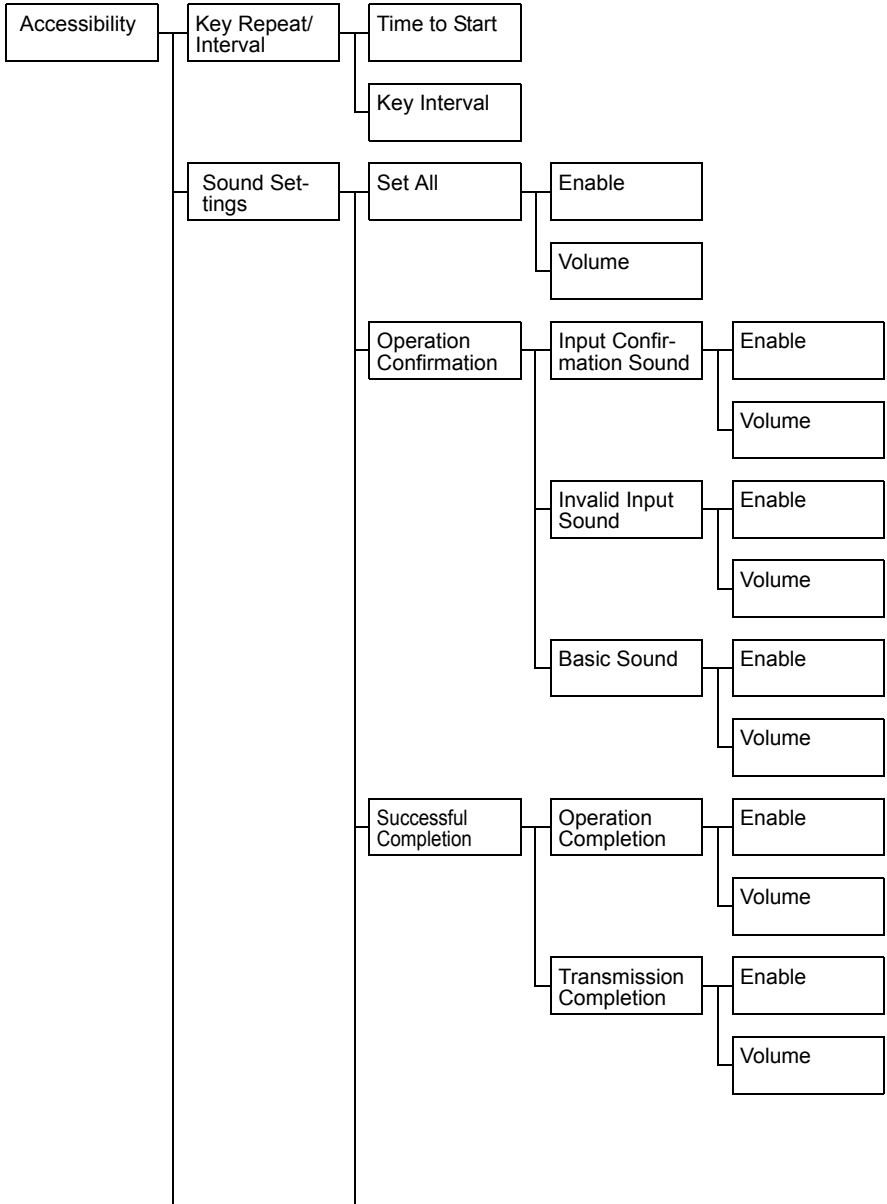

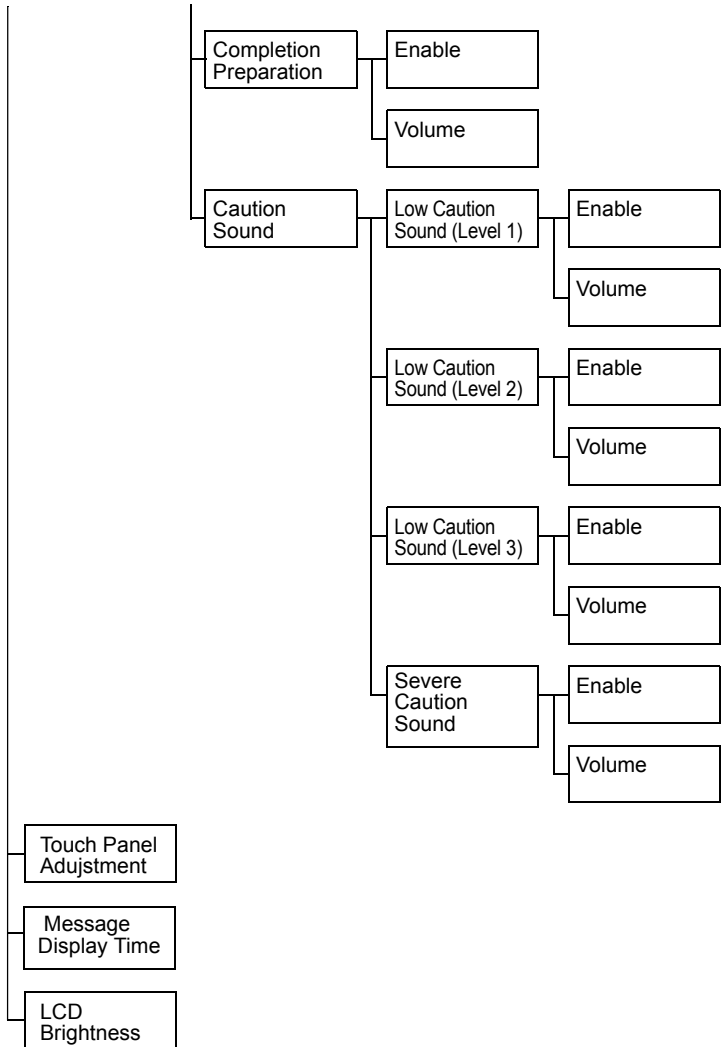

1 Press the [Utility/Counter] key.

2 Press [Accessibility].



*All factory default values are shown in bold.*

Item	Description	
[Key Repeat /Interval]	The length of time until the value begins to change after a button is held down and the length of time for the value to change can be specified.	
[Time to Start]	Settings	0.1 to 3.0 seconds (Default: <b>0.8</b> )
	Specify the length of time until a value begins to change after a button is held down.	
[Key Interval]	Settings	0.1 to 3.0 seconds (Default: <b>0.3</b> )
	Specify the length of time for the value to change.	
[Sound Settings]	Settings can be specified for the various sounds produced with key operations.	
[Set all]	Settings	Enable: [ON] / [OFF] Volume: [Low] / [Medium] / [High]
	To specify that sounds be produced, press [Enable], and then press [ON]. To adjust the volume, press [Volume], and then press [Low], [Medium] or [High]. To specify that sounds not be produced, press [Enable], and then press [OFF].	
[Operation Confirmation]	Select if confirmation sounds are to be produced with key operations.	
[Input Confirmation Sound]	Settings	Enable : <b>[ON]</b> / [OFF] Volume : [Low] / <b>[Medium]</b> / [High]
	Select whether sounds are produced when keys are pressed to enter data.	
[Invalid Input Sound]	Settings	Enable : <b>[ON]</b> / [OFF] Volume : [Low] / <b>[Medium]</b> / [High]
	Select whether sounds are produced when keys are pressed to enter invalid data.	
[Basic Sound]	Settings	Enable : <b>[ON]</b> / [OFF] Volume : [Low] / <b>[Medium]</b> / [High]
	Select whether sounds are produced when the default setting is selected while scrolling through the settings.	

[Successful Completion]	Select if sounds are to be produced when an operation or communication is completed successfully.	
[Operation Completion]	Settings	Enable : <b>[ON]</b> / [OFF] Volume : [Low] / <b>[Medium]</b> / [High]
	Select whether sounds are produced when an operation is completed successfully.	
[Transmission Completion]	Settings	Enable : <b>[ON]</b> / [OFF] Volume : [Low] / <b>[Medium]</b> / [High]
	Select whether sounds are produced when a communication is completed successfully.	
[Completion Preparation]	Settings	Enable : <b>[ON]</b> / [OFF] Volume : [Low] / <b>[Medium]</b> / [High]
	Select if sounds are to be produced when machine preparations are finished.	
[Caution Sound]	Select if sounds are to be produced when cautions occur.	
[Low Caution Sound (Level 1)]	Settings	Enable : <b>[ON]</b> / [OFF] Volume : [Low] / <b>[Medium]</b> / [High]
	Select whether sounds are produced when a message appears in the touch panel, warning that it is almost time to replace consumables or a replaceable part.	
[Low Caution Sound (Level 2)]	Settings	Enable : <b>[ON]</b> / [OFF] Volume : [Low] / <b>[Medium]</b> / [High]
	Select whether sounds are produced when the user performs an incorrect operation.	
[Low Caution Sound (Level 3)]	Settings	Enable : <b>[ON]</b> / [OFF] Volume : [Low] / <b>[Medium]</b> / [High]
	Select whether sounds are produced when an error occurs that can be corrected by the user by referring to the message that appeared or the User's Guide.	
[Severe Caution Sound]	Settings	Enable : <b>[ON]</b> / [OFF] Volume : [Low] / <b>[Medium]</b> / [High]
	Select whether sounds are produced when an error occurs that cannot be corrected by the user or requires a service representative.	

[Touch Panel Adjustment]	<p>If the touch panel buttons do not respond correctly, the position of buttons in the touch panel may not be correctly aligned with the position of the actual touch sensor and may need to be adjusted.</p> <ul style="list-style-type: none"> <li>■ Press the four check points ([+]) in the touch panel adjustment screen, making sure that a sound is produced with each, and then press the [Start] key.</li> <li>■ The check points ([+]) can be pressed in any order.</li> <li>■ To reset the adjustment, press the [C] key, and then press the four check points ([+]) again.</li> <li>■ To cancel the touch panel adjustment, press the [Stop] key.</li> <li>■ If the touch panel cannot be adjusted, contact the service representative.</li> </ul>	
[Message Display Time]	Settings	<p>[3 sec.] / [5 sec.]</p> <p>Specify the length of time for displaying warning messages, which appear, for example, when an incorrect operation is performed.</p>
[LCD Brightness]	Settings	<p>-3 to 3 (Default: 0)</p> <p>Adjust the contrast of the touch panel.</p>

# [Meter Count]

From the [Meter Count] screen, the page count for each function and the total page count can be viewed.

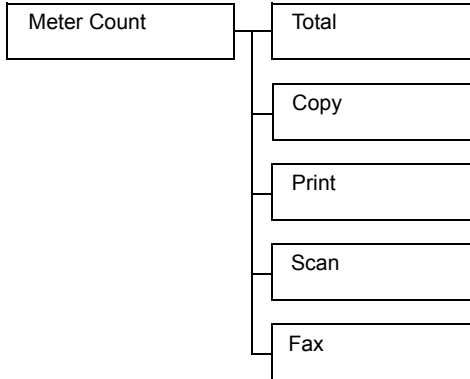

- 1 Press the [Utility/Counter] key.
- 2 Press [Meter Count].
- 3 Press [←], [→], [↑] or [↓] to display the desired information.

Item	Description
[Total]	Displays the total page count for each operation mode.
[Copy]	Displays the page count for copy operations.
[Print]	Displays the page count for print operations.
[Scan]	Displays the page count for scan operations.
[Fax]	Displays the page count for fax operations.

# [Address Registration]

From the [Address Registration] screen, E-mail and fax destinations can be registered and viewed.

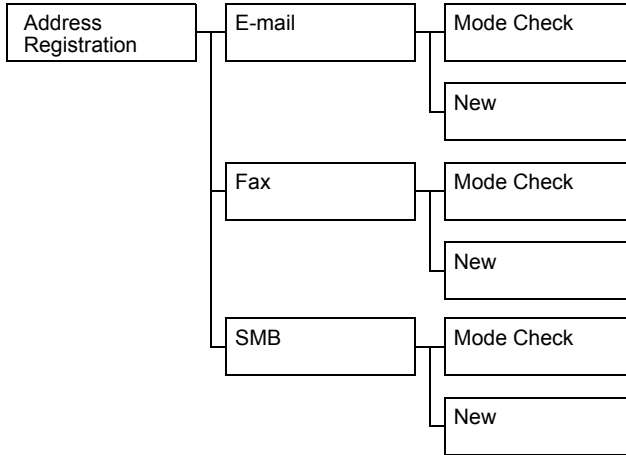

- 1 Press the [Utility/Counter] key.
- 2 Press [Address Registration].



*[Address Registration] does not appear if only account track settings have been specified and no user is logged on with an account.*

Item	Description
[E-mail]	Destinations for E-mail transmissions can be registered and viewed.  For details on registering, refer to “Registering an address book destination” on page 10-35.
[Mode Check]	Press to view the details for the selected destination.
[New]	Press to register a new destination.  Specify settings for [No.], [Name], [E-mail], [Favorites] and [Index].



Item	Description						
<table border="1"> <tr> <td data-bbox="188 113 452 229">[Fax]</td> <td data-bbox="452 113 1001 229">           Fax destinations can be registered and viewed.            For details on registering, refer to the [Facsimile User's Guide].         </td> </tr> <tr> <td data-bbox="188 229 452 300">[Mode Check]</td> <td data-bbox="452 229 1001 300">Press to view the details for the selected destination.</td> </tr> <tr> <td data-bbox="188 300 452 416">[New]</td> <td data-bbox="452 300 1001 416">           Press to register a new destination.            Specify settings for [No.], [Name], [Fax number], [Favorites], [Index] and [Line Settings].         </td> </tr> </table>	[Fax]	Fax destinations can be registered and viewed. For details on registering, refer to the [Facsimile User's Guide].	[Mode Check]	Press to view the details for the selected destination.	[New]	Press to register a new destination. Specify settings for [No.], [Name], [Fax number], [Favorites], [Index] and [Line Settings].	
[Fax]	Fax destinations can be registered and viewed. For details on registering, refer to the [Facsimile User's Guide].						
[Mode Check]	Press to view the details for the selected destination.						
[New]	Press to register a new destination. Specify settings for [No.], [Name], [Fax number], [Favorites], [Index] and [Line Settings].						
<table border="1"> <tr> <td data-bbox="188 416 452 560">[SMB]</td> <td data-bbox="452 416 1001 560">           Destinations for SMB transmissions can be registered and viewed.            For details on registering, refer to "Registering an address book destination" on page 10-35.         </td> </tr> <tr> <td data-bbox="188 560 452 630">[Mode Check]</td> <td data-bbox="452 560 1001 630">Press to view the details for the selected destination.</td> </tr> <tr> <td data-bbox="188 630 452 770">[New]</td> <td data-bbox="452 630 1001 770">           Press to register a new destination.            Specify settings for [No.], [Name], [Connection] ([Host Name], [File Path], [User ID], [Password]), [Favorites] and [Index].         </td> </tr> </table>	[SMB]	Destinations for SMB transmissions can be registered and viewed. For details on registering, refer to "Registering an address book destination" on page 10-35.	[Mode Check]	Press to view the details for the selected destination.	[New]	Press to register a new destination. Specify settings for [No.], [Name], [Connection] ([Host Name], [File Path], [User ID], [Password]), [Favorites] and [Index].	
[SMB]	Destinations for SMB transmissions can be registered and viewed. For details on registering, refer to "Registering an address book destination" on page 10-35.						
[Mode Check]	Press to view the details for the selected destination.						
[New]	Press to register a new destination. Specify settings for [No.], [Name], [Connection] ([Host Name], [File Path], [User ID], [Password]), [Favorites] and [Index].						

# [User Settings]

From the [User Settings] screen, various settings are available to be changed by the user.

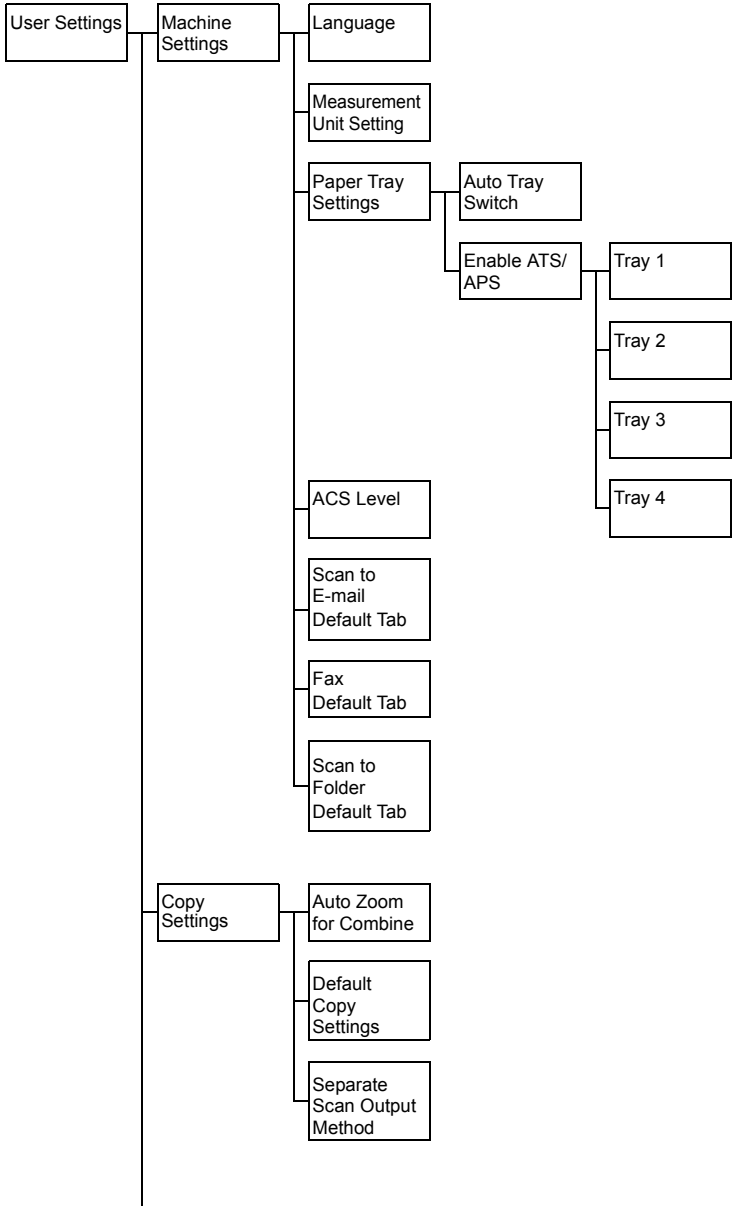

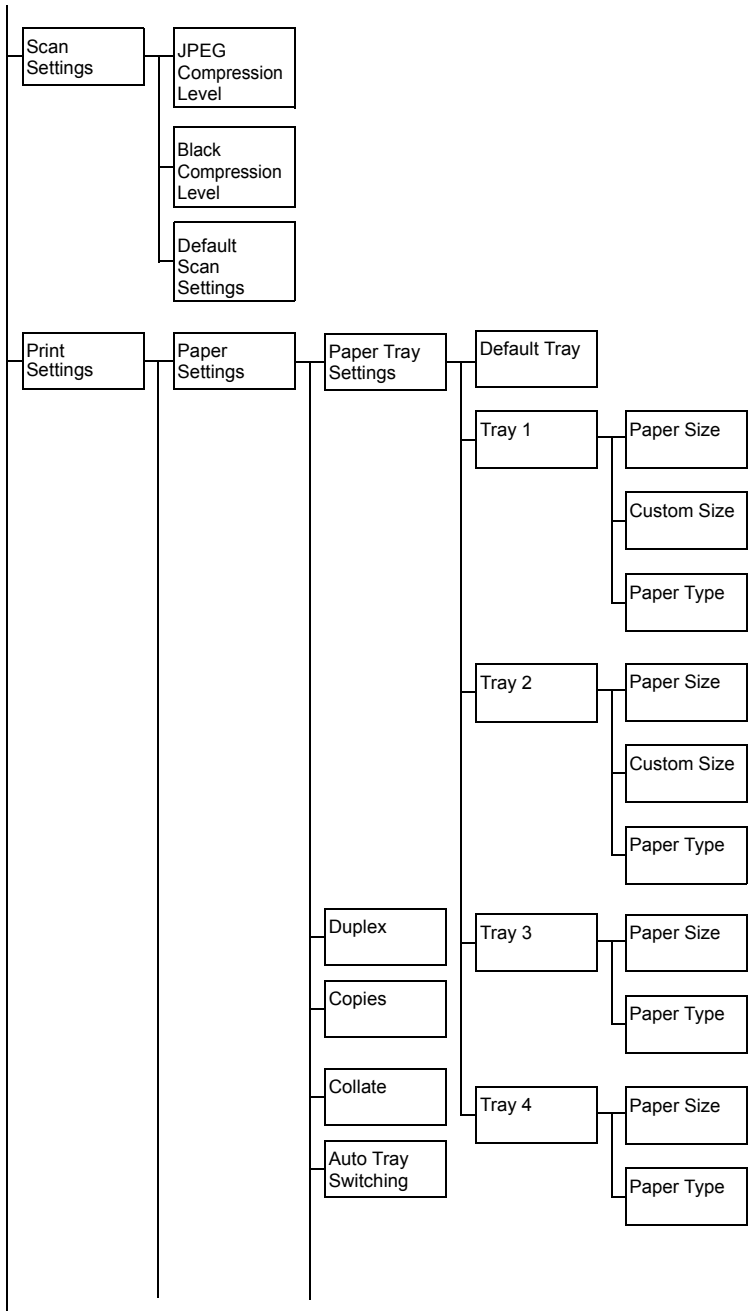

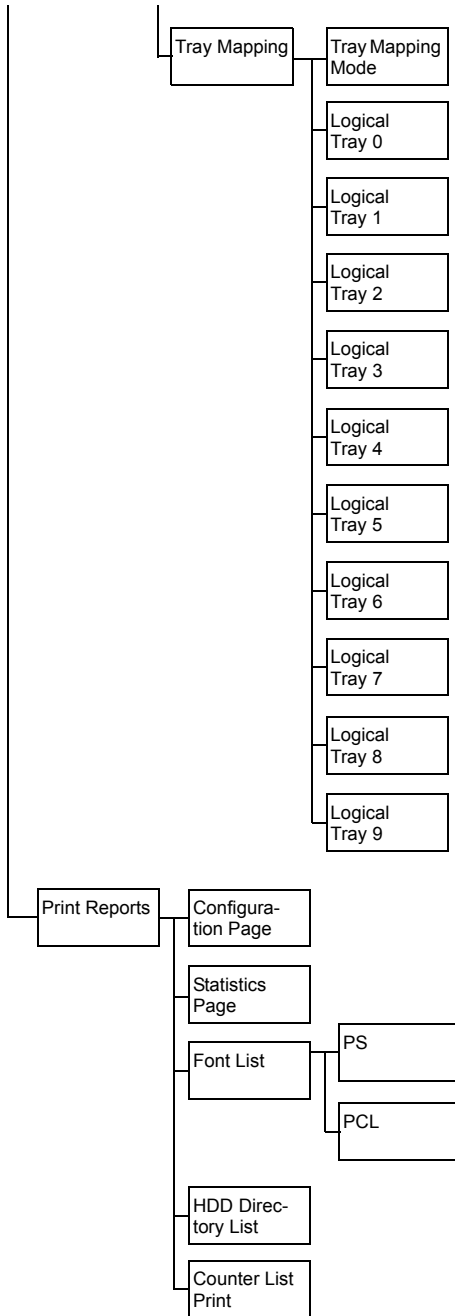

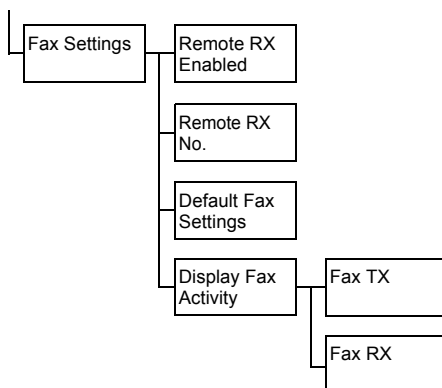



- 1 Press the [Utility/Counter] key.
- 2 Press [User Settings].

 *[User Settings] is not displayed when the job log is full.*

## [Machine Settings]

 *All factory default values are shown in bold.*

Item	Description	
[Language]	Settings	<b>[English]</b> / [French] / [Italian] / [German] / [Spanish] / [Portuguese] / [Hangul] / [Simplified Chinese] / [Traditional Chinese] / [Czech] / [Hungarian] / [Polish] / [Slovak] / [Russian] / [Dutch] / [Danish] / [Norwegian] / [Swedish] / [Finnish] / [Greek] / [Turkish] / [Catalan] / [Japanese]
		Specify the language for the screens that appear in the touch panel.
[Measurement Unit Setting]	Settings	<b>[Inch]</b> / <b>[mm]</b>
		Select the measurement units for the values that appear in the touch panel screens.
		 <i>The default setting is [Inch] for 120V model, and [mm] for other models.</i>

[Paper Tray Settings]	Specify paper tray settings.	
[Auto Tray Switch]	Settings	[ON] / [OFF]
	Select whether or not a paper tray loaded with paper of the same size is selected automatically when a paper tray that was selected manually becomes empty while printing copies.	
[Enable ATS/APS]	Specify the paper trays that are selected when the paper tray is automatically changed.  [Tray 3] and [Tray 4] do not appear if the optional lower feeder units have not been installed.	
[Tray 1]	Settings	[ON] / [OFF]
	Select whether or not [Tray 1] can be selected with the automatic tray-switching feature.	
[Tray 2]	Settings	[ON] / [OFF]
	Select whether or not [Tray 2] can be selected with the automatic tray-switching feature.	
[Tray 3]	Settings	[ON] / [OFF]
	Select whether or not [Tray 3] can be selected with the automatic tray-switching feature.	
[Tray 4]	Settings	[ON] / [OFF]
	Select whether or not [Tray 4] can be selected with the automatic tray-switching feature.	
[ACS Level]	Settings	0 to 4 (Default: 2)
Adjust the level for detecting whether a document is in color or in black and white when the [Auto] Color setting is selected. Set to [0] or [1] for a tendency toward black and white, or set to [3] or [4] for a tendency toward color.		
[Scan to E-mail Default Tab]	Settings	[Favorites] / [Direct Input] / [Log]
Specify the initial screen when changing to the E-mail transmission screen.		
[Fax Default Tab]	Settings	[Favorites] / [Direct Input] / [Others]
Specify the initial screen when changing to the fax transmission screen.		

[Scan to Folder Default Tab]	Settings	[ <b>Favorites</b> ] / [Direct Input] / [Log]
	Specify the initial screen when changing to the folder transmission screen.	

## [Copy Settings]



*All factory default values are shown in bold.*

Item	Description	
[Auto Zoom for Combine]	Settings	[ <b>Yes</b> ] / [No]
	Select whether or not the zoom ratio is automatically adjusted when the [Auto] Paper setting and a Combine setting are selected.	
[Default Copy Settings]	Settings	[ <b>Factory Default</b> ] / [Current Setting]
	<p>Select the default copy settings that are selected when the machine is turned on or the [Reset] key is pressed.</p> <p>[Factory Default]: The manufacturer's default settings are used as the default settings.</p> <p>[Current Setting]: The currently specified settings are used as the default settings.</p>	
[Separate Scan Output Method]	Settings	[Batch Print] / [ <b>Page Print</b> ]
	<p>Select whether or not printing begins after all document pages have been scanned when the document is divided and the batches are separately loaded into the ADF or when the original glass is being used to scan a document containing multiple pages.</p> <p>[Batch Print]: Printing begins after all pages of the document have been scanned.</p> <p>[Page Print]: Printing of pages that can be printed begins while the document is being scanned.</p>	

## [Scan Settings]



All factory default values are shown in bold.



Item	Description	
[JPEG Compression Level]	Settings	[High Quality] / <b>[Standard]</b> / [High Compression]
	<p>Select the compression method for saving an image in full color.</p> <p>[High Quality]: The data size will become large, but the image quality will be high.</p> <p>[Standard]: Both the data size and image quality will be between those of [High Quality] and [High Compression].</p> <p>[High Compression]: The data size will become small, but the image quality will be low.</p>	
[Black Compression Level]	Settings	[MH] / <b>[MMR]</b>
	<p>Select this machine's transmission quality when sending data with the TIFF file format selected.</p> <p>[MH]: The data size will become large.</p> <p>[MMR]: The data size will become small.</p>	
[Default Scan Settings]	Settings	<b>[Factory Default]</b> / [Current Setting]
	<p>Select the default scan settings that are selected when the machine is turned on or the [Reset] key is pressed.</p> <p>[Factory Default]: The manufacturer's default settings are used as the default settings.</p> <p>[Current Setting]: The currently specified settings are used as the default settings.</p>	











## [Print Settings]



All factory default values are shown in bold.

Item	Description		
[Paper Settings]	Specify settings for the paper and paper trays.		
[Paper Tray Settings]	Specify settings for the paper trays.		
[Default Tray]	<table border="1" data-bbox="508 300 1005 363"> <tr> <td data-bbox="508 300 620 363">Settings</td> <td data-bbox="620 300 1005 363">[Tray 1] / <b>[Tray 2]</b> / [Tray 3] / [Tray 4]</td> </tr> </table> <p data-bbox="508 363 1005 400">Select the paper tray that is given priority.</p> <p data-bbox="508 400 1005 528">  <i>[Tray 3] and [Tray 4] do not appear if the optional lower feeder units have not been installed.</i> </p>	Settings	[Tray 1] / <b>[Tray 2]</b> / [Tray 3] / [Tray 4]
Settings	[Tray 1] / <b>[Tray 2]</b> / [Tray 3] / [Tray 4]		
[Tray 1]-[Tray 4]	<p data-bbox="508 528 1005 592">Specify the default settings for [Tray 1] through [Tray 4].</p> <p data-bbox="508 592 1005 715">  <i>[Tray 3] and [Tray 4] do not appear if the optional lower feeder units have not been installed.</i> </p>		

[Paper Size]	Settings	[Any] / <b>[Letter]</b> / [Legal] / [Executive] / <b>[A4]</b> / [A5] / [A6] / [B5 (JIS)] / [B6] / [Govt Letter] / [Statement] / [Folio] / [SP Folio] / [UK Quarto] / [Foolscap] / [Govt Legal] / [16K] / [4×6] / [Kai 16] / [Kai 32] / [Env C6] / [Env DL] / [Env Monarch] / [Env Chou#3] / [Env Chou#4] / [B5 (ISO)] / [Env #10] / [J Postcard] / [J Postcard-D] / [8 1/8×13 1/4] / [8 1/2×13 1/2] / [Custom Size]
		<p>Select the size of paper loaded in the selected tray.</p> <p> <i>The default setting is [Letter] for 120V model, and [A4] for other models.</i></p> <p> <i>Depending on the setting selected for [User Settings] - [Machine Settings] - [Measurement Unit Setting], 4 × 6 may change to 10 × 15 cm.</i></p> <p> <i>With [Tray 2], [Env C6], [Env DL], [Env Monarch], [Env Chou#3], [Env Chou#4], [B5 (ISO)], [Env #10] do not appear.</i></p> <p> <i>With [Tray 3] and [Tray 4], only [Letter], [Legal], [Govt Legal], [Executive], [A4] and [B5 (JIS)] appear.</i></p>
[Custom Size]		<p>Press [Width] and [Length], and then type in the paper size.</p> <p> <i>These settings can be specified if [Paper Size] is set to [Custom].</i></p> <p> <i>Settings for [Custom Size] cannot be specified for [Tray 3] and [Tray 4].</i></p>

		[Paper Type]	Settings	[Any] / <b>[Plain Paper]</b> / [Recycled] / [Thick 1] / [Thick 2] / [Label] / [Envelope] / [Postcard] / [Letterhead] / [Glossy 1] / [Glossy 2] / [1 Side Only] / [Special Paper]
		<p>Select the type of paper loaded in the selected tray.</p> <p> <i>[Envelope] appears only with [Tray 1].</i></p> <p> <i>With [Tray 3] and [Tray 4], only [Any], [Plain Paper], [Recycled], [1 Side Only] and [Special Paper] appear.</i></p>		
[Duplex]		Settings	<b>[OFF]</b> / [Long Edge] / [Short Edge]	
		<p>Select whether pages are printed double-sided.</p> <p>If [Long Edge] is selected, the pages will be printed on both sides of the paper for long-edge binding.</p> <p>If [Short Edge] is selected, the pages will be printed on both sides of the paper for short-edge binding.</p>		
[Copies]		Settings	1 to 9999 (Default: 1)	
		Specify the number of copies to be printed.		
[Collate]		Settings	<b>[ON]</b> / <b>[OFF]</b>	
		Select whether or not to enable collated (sort) printing.		
[Auto Tray Switching]		Settings	<b>[ON]</b> / <b>[OFF]</b>	
		<p>If [ON] is selected and the specified tray runs out of paper during printing, a tray loaded with paper of the same size is automatically selected so printing can continue.</p> <p>If [OFF] is selected and the specified tray runs out of paper, printing stops.</p>		

[Tray Mapping]	Specify the Tray Mapping settings.	
[Tray Mapping Mode]	Settings	[ON] / <b>[OFF]</b>
	Select whether or not the Tray Mapping function is used.	
[Logical Tray 0]- [Logical Tray 9]	Settings	[Physical Tray 1] / <b>[Physical Tray 2]</b> / [Physical Tray 3]
	 For [Logical Tray 1], the default value is [Physical Tray 1]. Select the tray that is used for printing when a print job is received from another manufacturer's printer driver.	
[Print Reports]	Specify settings for printing the various reports.	
[Configuration Page]	Prints information and status of this machine.	
[Statistics Page]	Prints the statistics page.	
[Font List]	Prints the font list.	
[PS]	Prints the PostScript font list.	
[PCL]	Prints the PCL font list.	
[HDD Directory List]	Prints the directory list for the hard disk.	
[Counter List Print]	Prints the list of counters.	

## [Fax Settings]

Specify the fax settings. For details on specifying the fax settings, refer to the [Facsimile User's Guide].

## [Select Default Start App]

This screen appears when an available application is registered while Enhanced Server Authentication is enabled.

# [Admin Settings]

From the Admin Settings screen, various settings are available to be changed by the machine administrator. In order to display the Admin Settings screen, the user must log on using the administrator password.

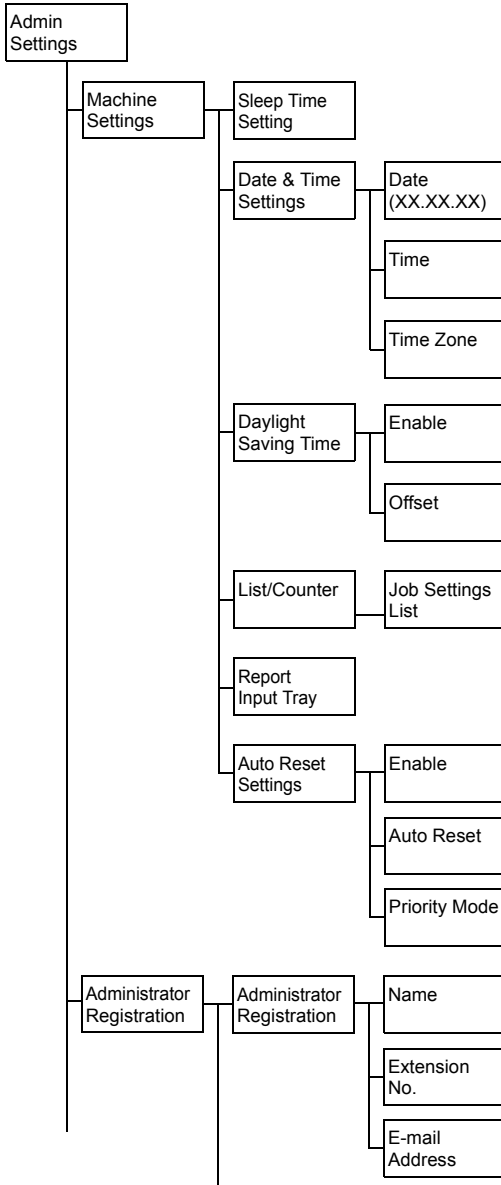

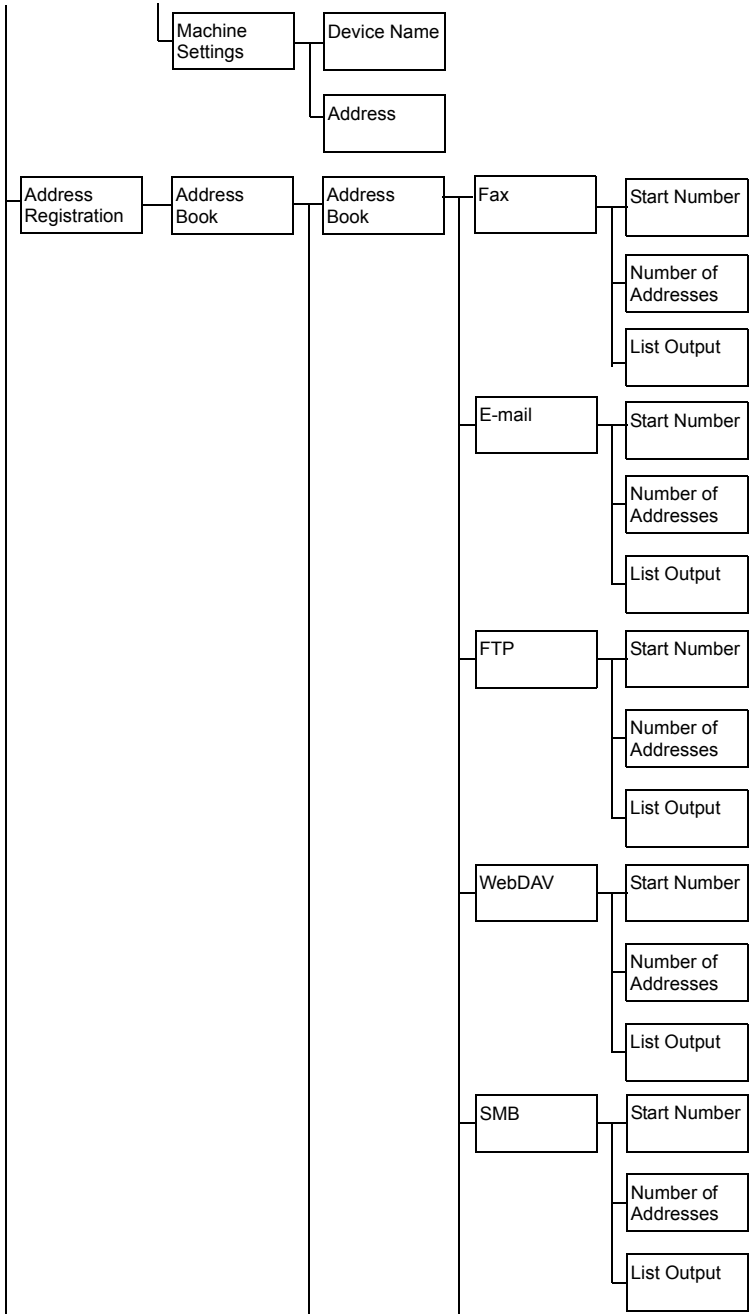

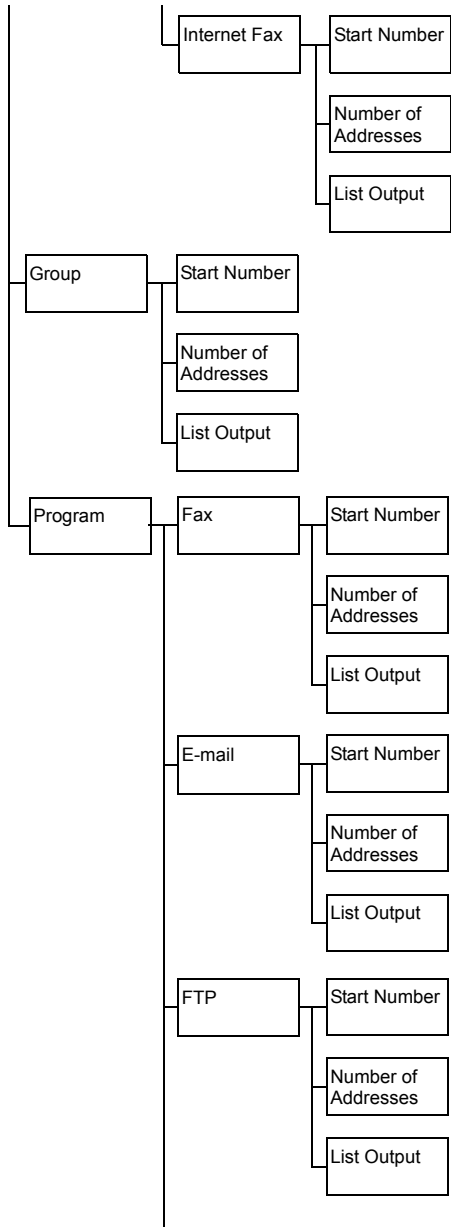

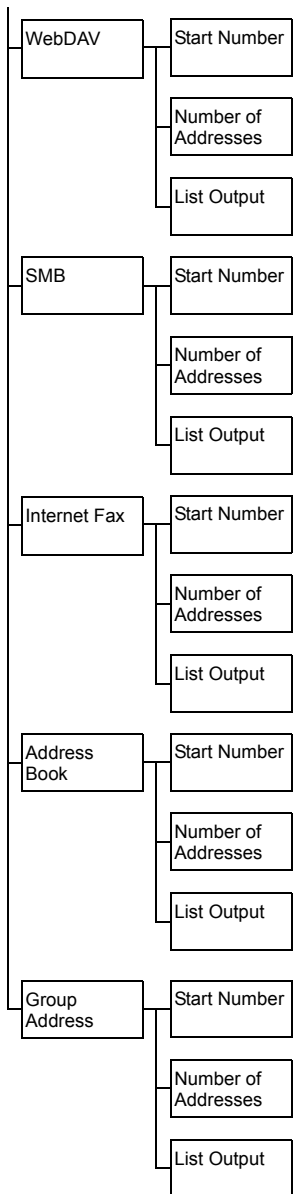



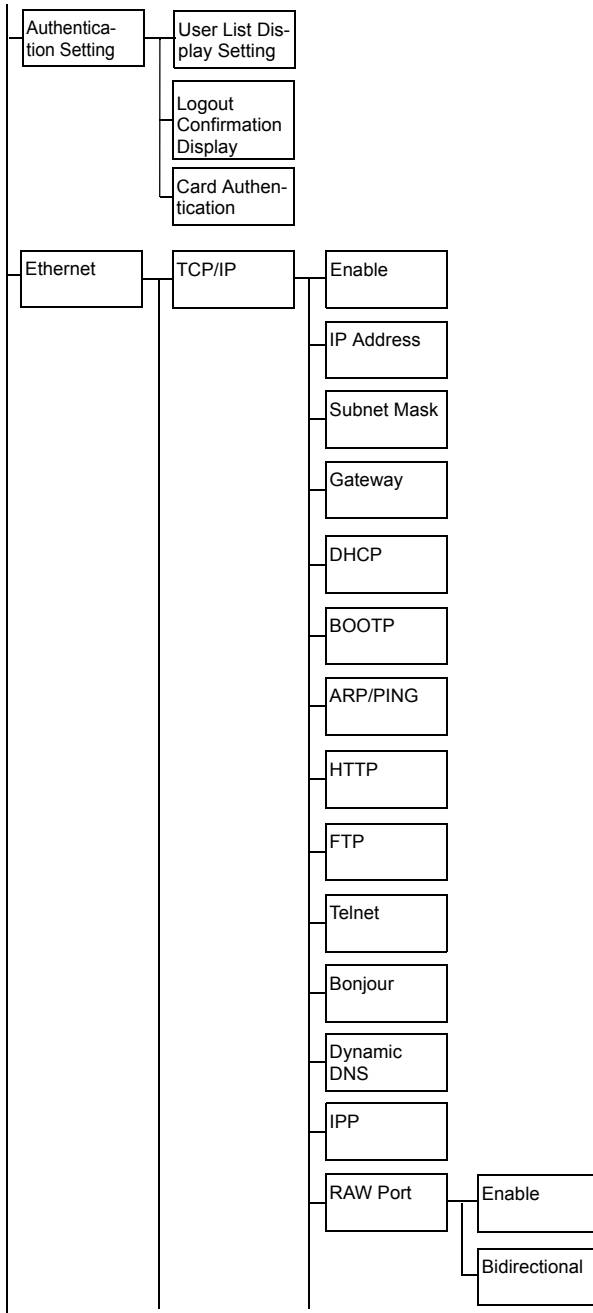

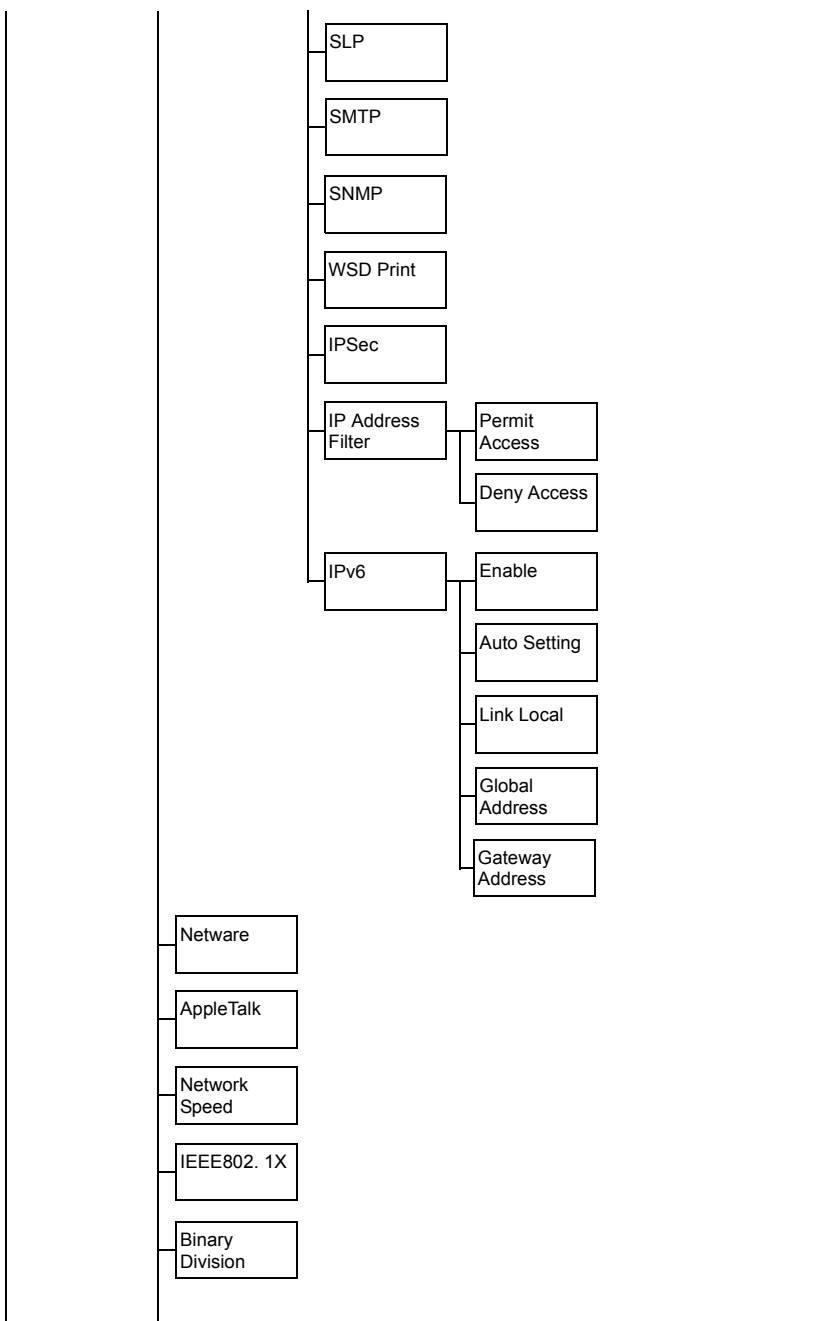

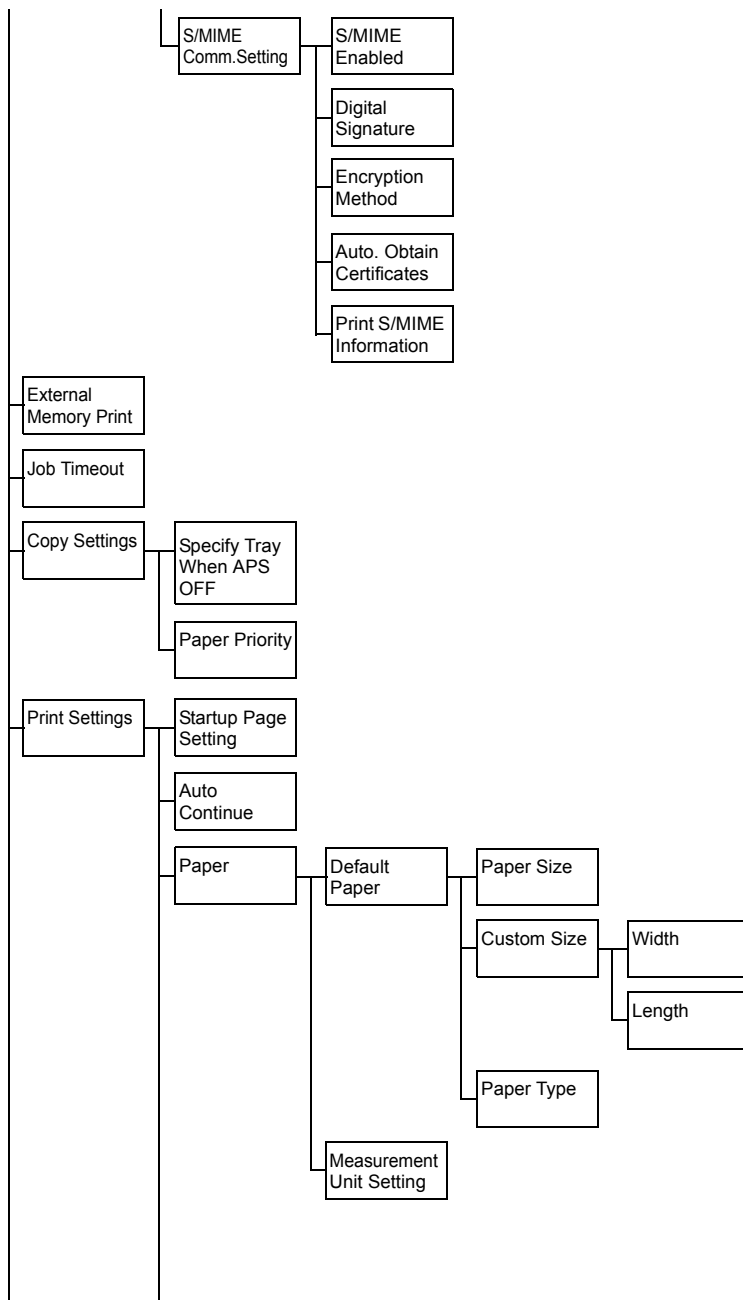

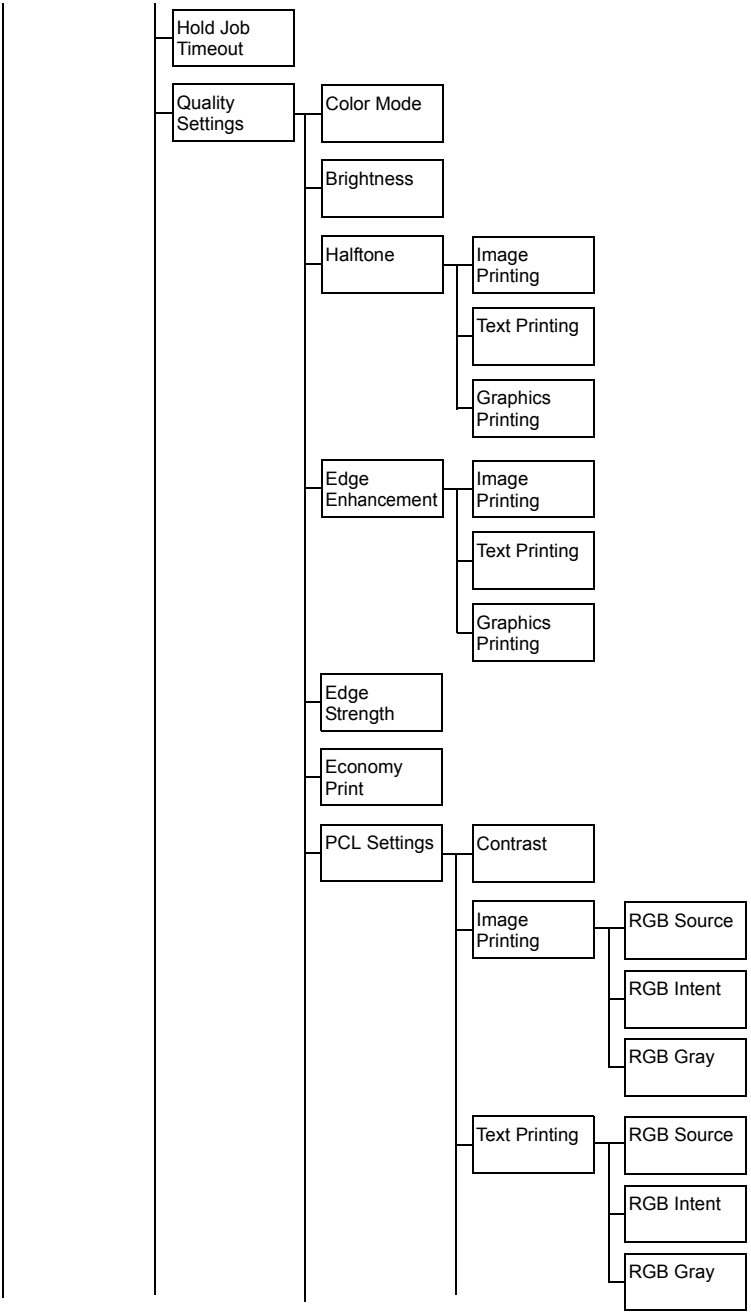

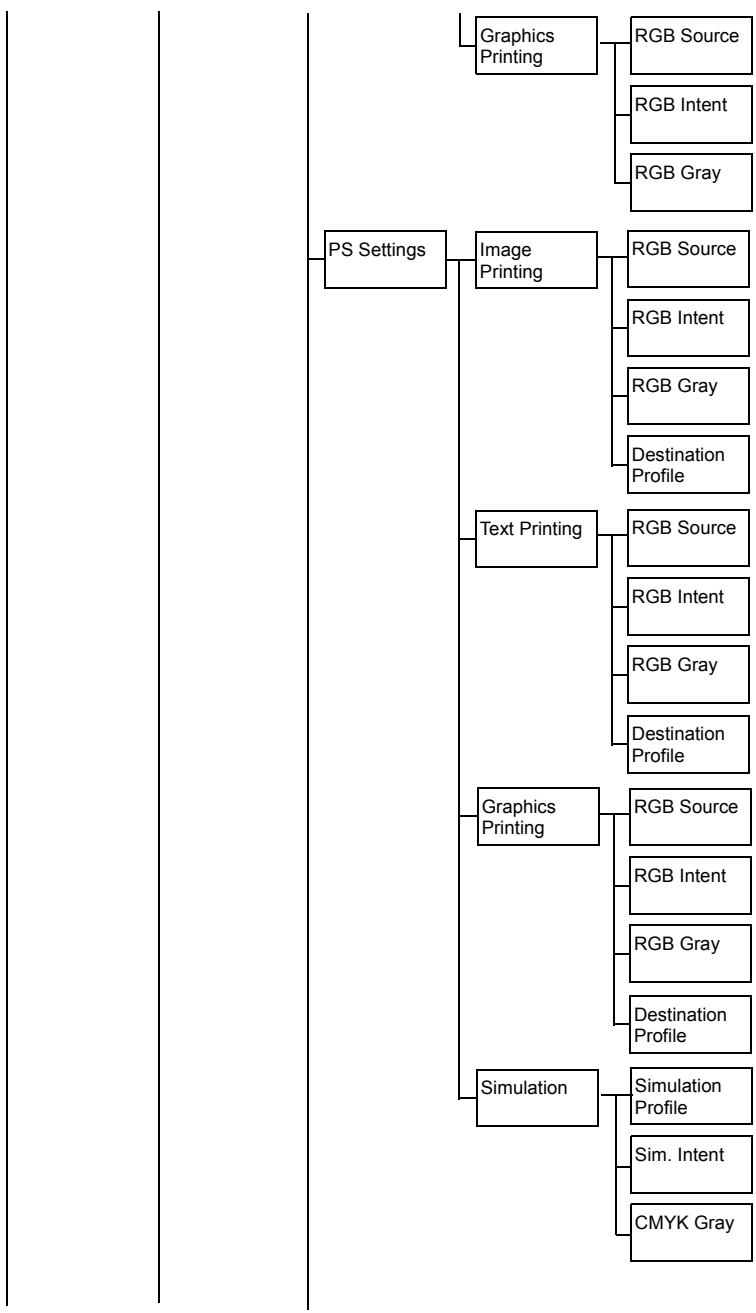

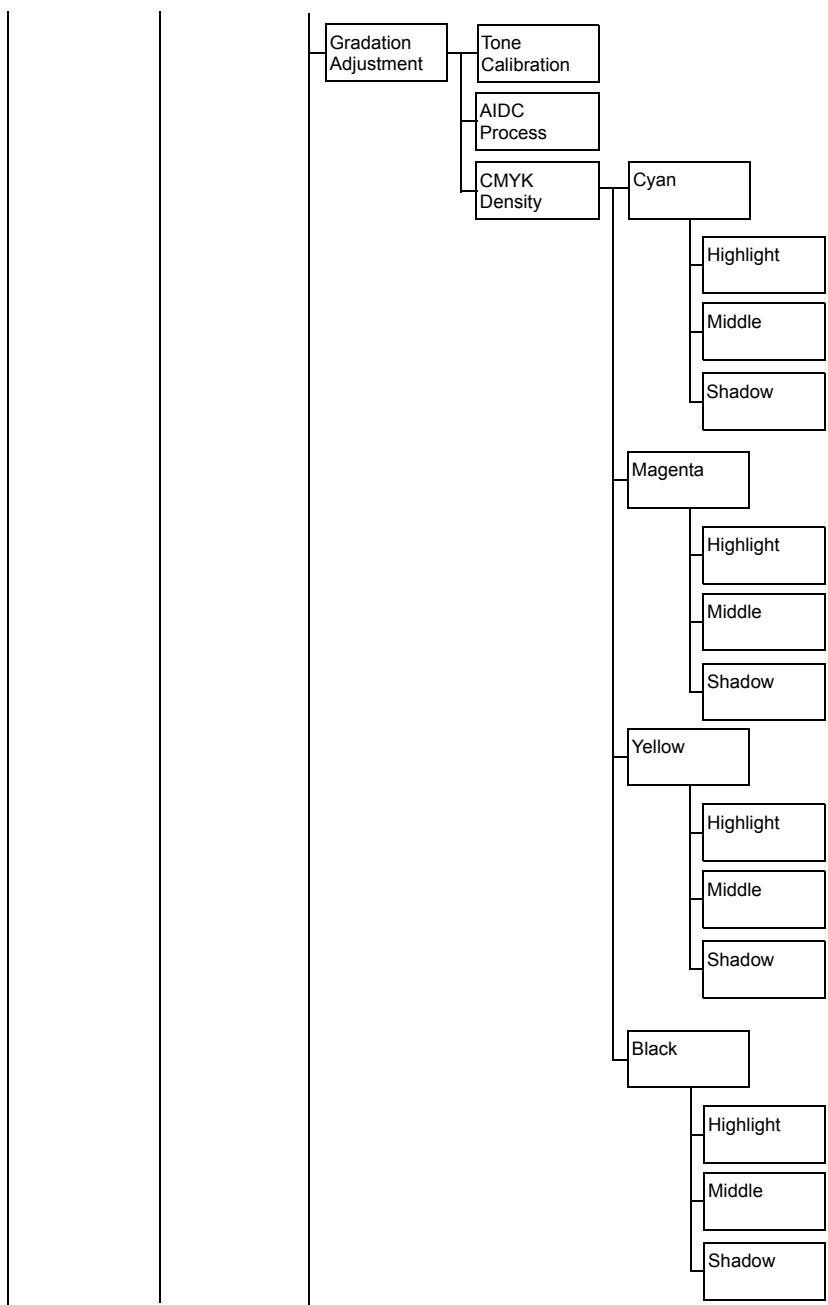

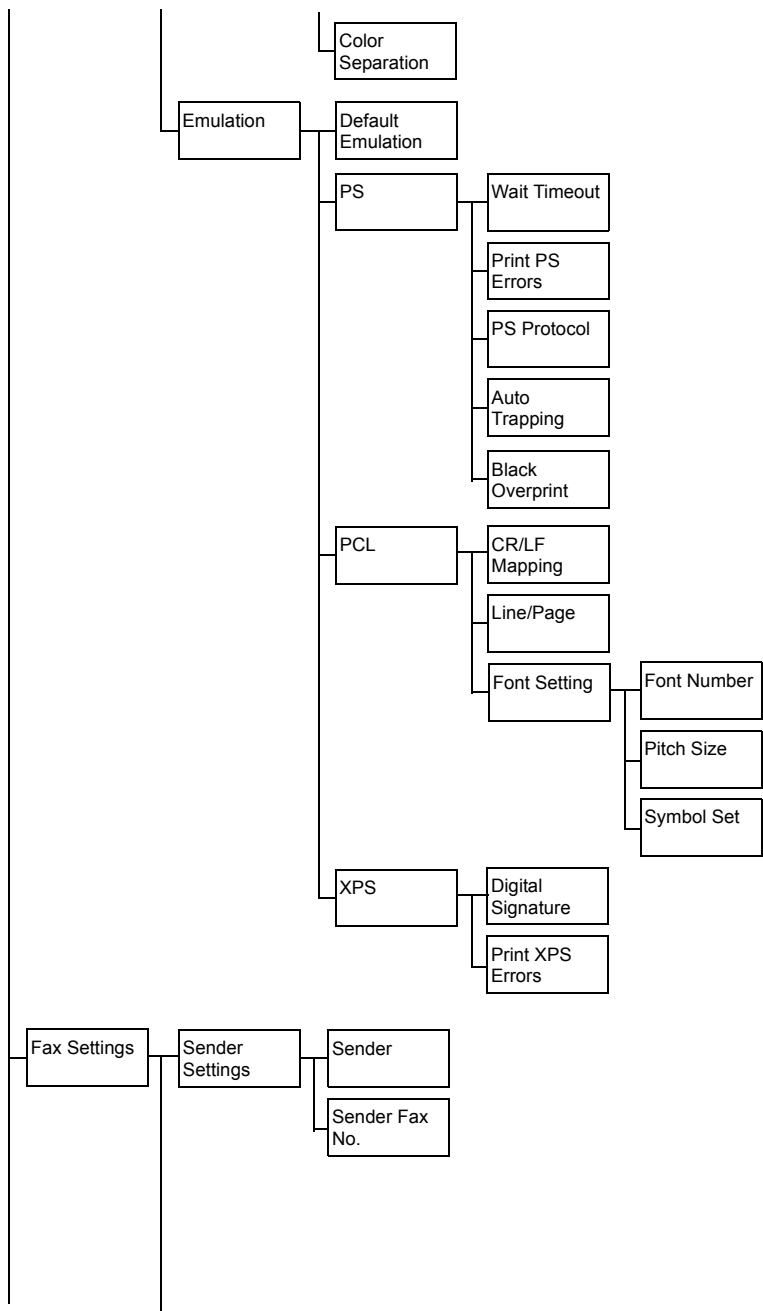

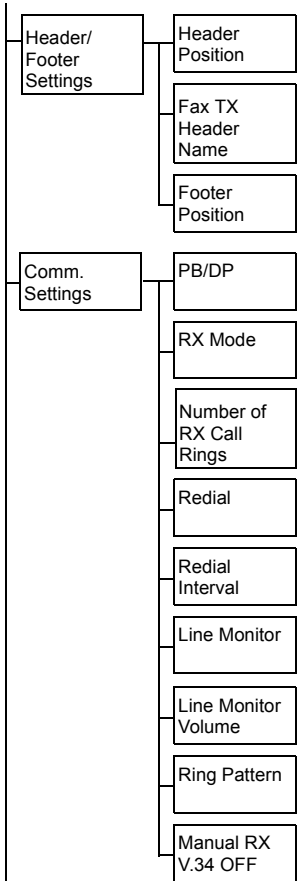



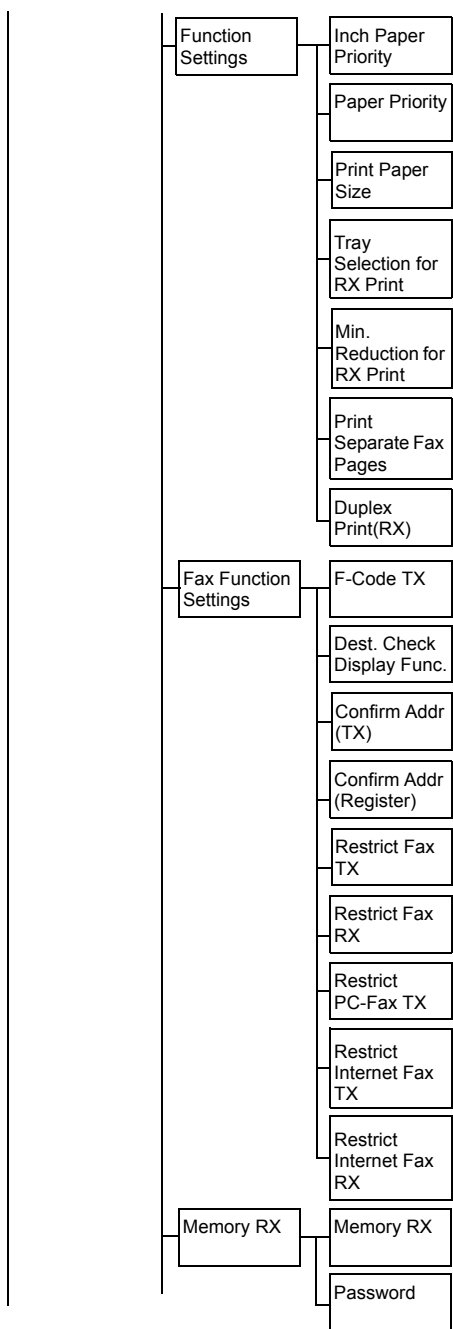

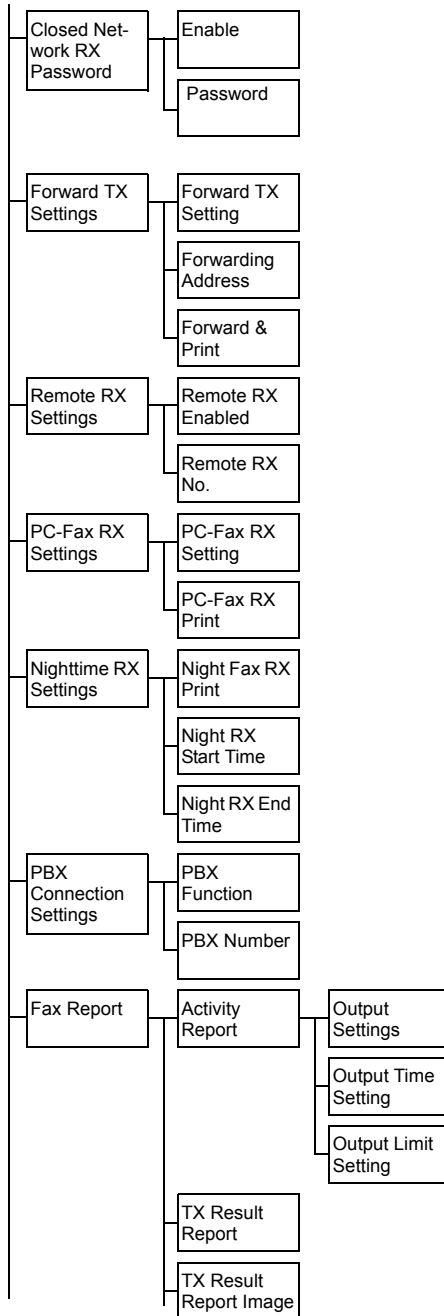

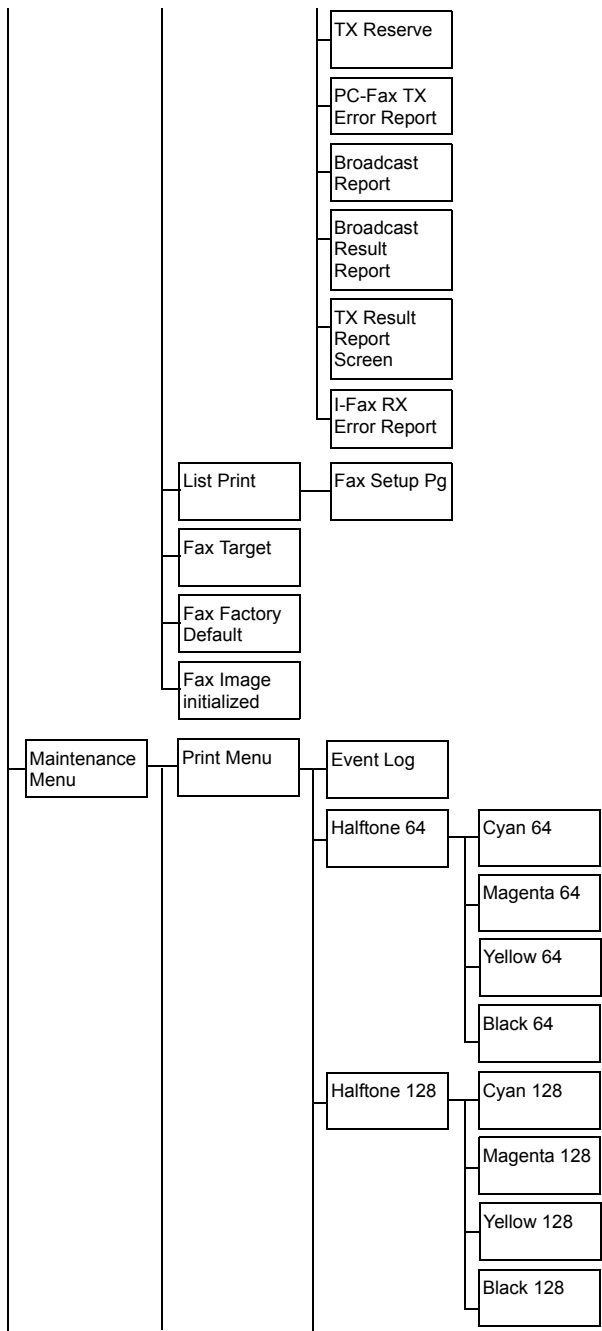

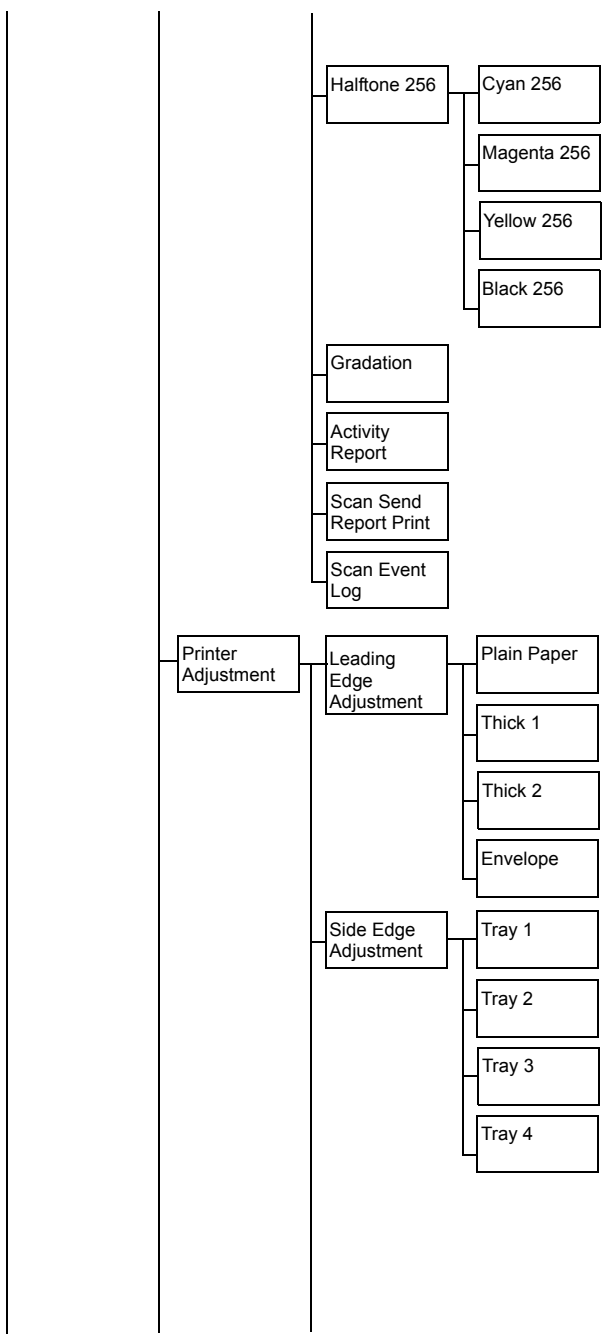

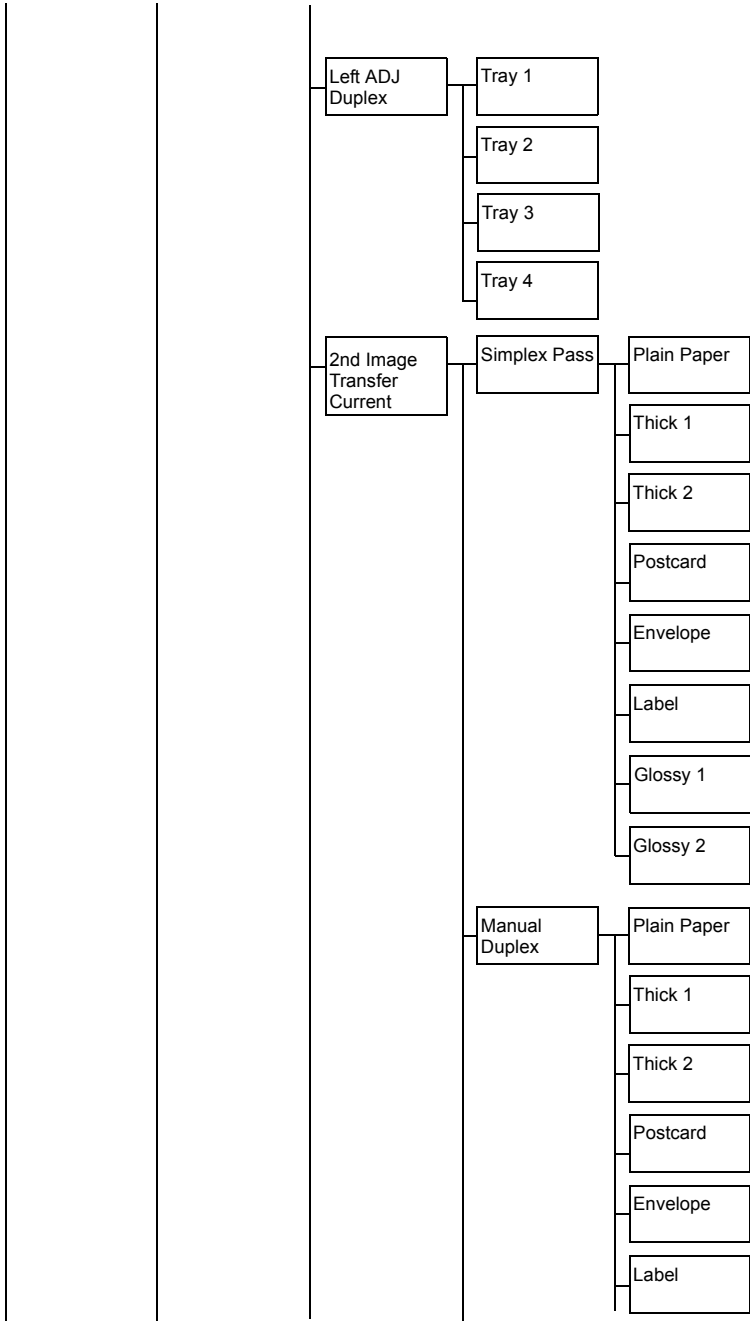

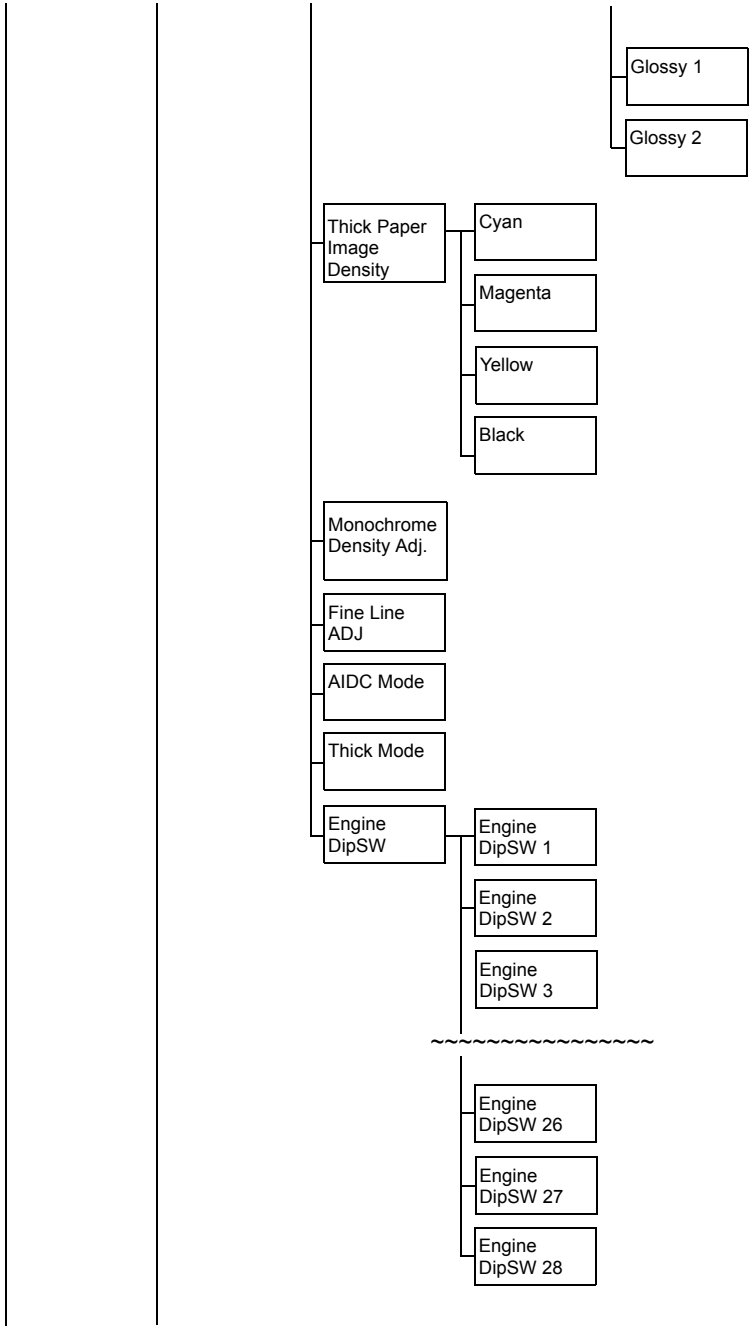

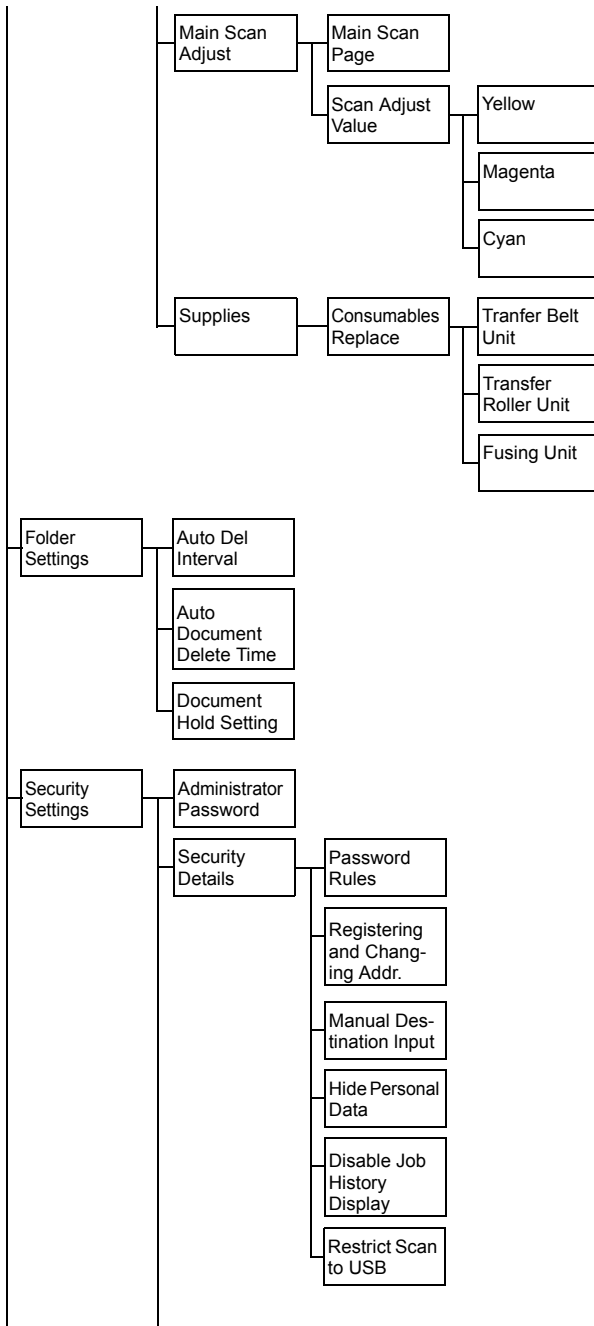

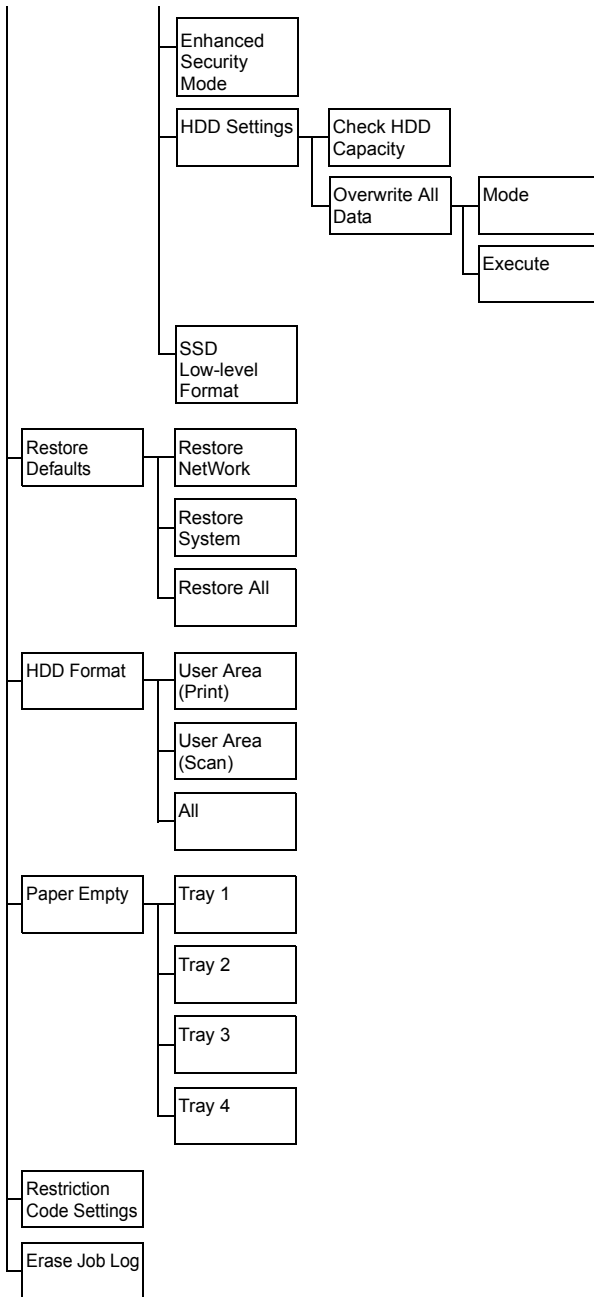



- 1 Press the [Utility/Counter] key.
- 2 Press [Admin Settings].
- 3 Type in the administrator password (default:12345678).



*If the administrator password (default:12345678) is incorrectly entered three times, machine operations are locked. If this occurs, turn the machine off, then on again.*

- 4 Press [OK].

## [Machine Settings]



*All factory default values are shown in bold.*

Item	Description	
[Sleep Time Setting]	Settings	[5 min.] / [6 min.] / [7 min.] / [8 min.] / [9 min.] / [ <b>10 min.</b> ] / [11 min.] / [12 min.] / [13 min.] / [14 min.] / [15 min.] / [30 min.] / [1 Hour] / [3 Hours]
	Specify the length of time until the machine enters Power Save mode.	
[Date & Time Settings]	Specify the date, time and time zone.	
[Date (XX.XX.XX)]	Specify the current date. <i>The default setting is set in the order month, day, then year (MM.DD.YY) for 120V model, month, then year (DD.MM.YY) for 220V model (Europe), and year, month, then day (YY.MM.DD) for 220V model (Asia and China).</i>	
[Time]	Specify the current time.	
[Time Zone]	Settings	-12:00 to +13:00 (Default: <b>00:00</b> )
	The time zone can be set between -12:00 and +13:00 (in 30-minute increments).	

[Daylight Saving Time]	Specify settings for daylight saving time.	
[Enable]	Settings	[ON] / [OFF]
	Select whether or not the machine's internal clock observes daylight saving time. If [ON] is selected, the specified time offset from the current time appears.	
[Offset]	Settings	1 to 150 (Default: <b>60</b> )
	Specify the length of time applied for daylight saving time between 1 and 150 minutes (in 1-minute increments).	
[List/Counter]	The machine settings can be printed.	
[Job Settings List]	Settings	[Print] / [Cancel]
	Prints the list of machine settings.	
[Report Input Tray]	Settings	[Tray 1] / [Tray 2] / [Tray 3] / [Tray 4]
	Select the paper tray loaded with the paper used to print reports.	
[Auto Reset Settings]	Specify settings to automatically reset copy settings after the specified time period has lapsed.	
[Enable]	Settings	[ON] / [OFF]
	Select whether or not to reset after the specified time period has lapsed.	
[Auto Reset]	Settings	1 to 9 (Default: <b>1</b> )
	Specify the time required to reset.	
[Priority Mode]	Settings	[Home] / [Copy] / [E-mail] / [Folder] / [Fax]
	Select the function to be displayed on the screen after resetting.	

## [Administrator Registration]

Item	Description
[Administrator Registration]	Specify administrator information.
[Name]	Specify the name of the administrator.
[Extension No.]	Specify the extension number for the administrator.
[E-mail Address]	Specify the E-mail address for the administrator.   <i>This is the From address for E-mail messages sent from this machine and the address where machine status notifications will be sent.</i>
[Machine Settings]	Specify machine information.
[Device Name]	Specify the name of the machine.  The name specified for [Device Name] will be used as the file name for scan data.
[Address]	Specify the E-mail address for the machine.

## [Address Registration]

Item	Description
[Address Book]	The destination lists for [Address Book], [Group] and [Program] can be printed or viewed.
[Address Book]	Specify settings for printing the list of address book destinations.
[Fax]/[E-mail]/[FTP]/ [WebDAV]/[SMB]/ [Internet Fax]	[Start Number]: Specify the starting address book destination number.  [Number of Addresses]: Specify the number of address book destinations.  [List Output]: Prints the list of address book destinations.

[Group]	Specify settings for printing the list of group destinations.  [Start Number]: Specify the starting group destination number.  [Number of Addresses]: Specify the number of group destinations.  [List Output]: Prints the list of group destinations.
[Program]	Specify settings for printing the list of program destinations.  [Start Number]: Specify the starting program destination number.  [Number of Addresses]: Specify the number of program destinations.  [List Output]: Prints the list of program destinations.
[Fax]/[E-mail]/[FTP]/ [WebDAV]/[SMB]/ [Internet Fax]/ [Address Book]/ [Group Address]	[Start Number]: Specify the starting program destination number.  [Number of Addresses]: Specify the number of program destinations.  [List Output]: Prints the list of program destinations.

## [Authentication Setting]



*All factory default values are shown in bold.*

Item	Description	
[User List Display Setting]	Settings	[ON] / <b>[OFF]</b>
	Select whether or not to display a user list.	
[Logout Confirmation Display]	Settings	[ON] / <b>[OFF]</b>
	Select whether or not a logoff confirmation message appears after the [Access] key is pressed.	
[Card Authentication]	<p>Displayed only when the authentication device is connected, and used to register IC card information for the user.</p> <p>For details, refer to “Authentication device (IC card type)” on page 15-1.</p>	

## [Ethernet]



All factory default values are shown in bold.

Item	Description	
[TCP/IP]	Specify network settings for the machine.	
[Enable]	Settings	<b>[ON]</b> / [OFF]
	Select the setting for connecting to this machine through a network.   If [OFF] is selected, the TCP/IP parameters do not appear.	
[IP Address]	Settings	[0.0.0.0]
	Specify the IP address used by this machine on the network.	
[Subnet Mask]	Settings	[0.0.0.0]
	Specify the subnet mask.	
[Gateway]	Settings	[0.0.0.0]
	Specify the gateway address.	
[DHCP]	Settings	<b>[ON]</b> / [OFF]
	If there is a DHCP server on the network, specify whether the IP address and other network information are automatically assigned by the DHCP server.	
[BOOTP]	Settings	[ON] / <b>[OFF]</b>
	If there is a BOOTP server on the network, specify whether the IP address and other network information are automatically assigned by the BOOTP server.	
[ARP/PING]	Settings	[ON] / <b>[OFF]</b>
	Select whether or not the ARP/PING command is used when the IP address is assigned.	
[HTTP]	Settings	<b>[Enable]</b> / [Disable]
	Select whether or not to enable HTTP.	
[FTP]	Settings	<b>[Enable]</b> / [Disable]
	Select whether or not to enable the FTP server.	

[Telnet]	Settings	<b>[Enable]</b> / [Disable]
	Select whether or not to enable Telnet transmissions.	
[Bonjour]	Settings	<b>[Enable]</b> / [Disable]
	Select whether or not to enable Bonjour.	
[Dynamic DNS]	Settings	[Enable] / <b>[Disable]</b>
	Select whether or not to enable Dynamic DNS.	
[IPP]	Settings	<b>[Enable]</b> / [Disable]
	Select whether or not to enable IPP.	
[RAW Port]	Specify the RAW port settings.	
[Enable]	Settings	<b>[Yes]</b> / [No]
	Select whether or not to enable the RAW port.	
[Bidirectional]	Settings	[ON] / <b>[OFF]</b>
	Select whether or not to enable RAW port bidirectional communication.	
[SLP]	Settings	<b>[Enable]</b> / [Disable]
	Select whether or not to enable SLP.	
[SMTP]	Settings	<b>[Enable]</b> / [Disable]
	Select whether or not to enable E-mail transmission operations for this machine.	
[SNMP]	Settings	<b>[Enable]</b> / [Disable]
	Select whether or not to enable SNMP.	
[WSD Print]	Settings	<b>[Enable]</b> / [Disable]
	Select whether or not to enable WSD printing.	
[IPSec]	Settings	[Enable] / <b>[Disable]</b>
	Select whether or not to enable IPsec.	
[IP Address Filter]	Specify IP address filtering settings.	
[Permit Access]	Settings	[Enable] / <b>[Disable]</b>
	Specify access permissions for IP address filtering.	
[Deny Access]	Settings	[Enable] / <b>[Disable]</b>
	Specify access blocking for IP address filtering.	

[IPv6]	Specify IPv6 settings.	
[Enable]	Settings	[ON] / [OFF]
	Select whether or not to enable IPv6.	
[Auto Setting]	Settings	[Enable] / [Disable]
	Select whether or not to enable the IPv6 auto setting.	
[Link Local]	Displays the link-local address.	
[Global Address]	Displays the global address.	
[Gateway Address]	Displays the gateway address.	
[Netware]	Settings	[Enable] / [Disable]
	Select whether or not to enable NetWare.	
[AppleTalk]	Settings	[Enable] / [Disable]
	Select whether or not to enable AppleTalk.	
[Network Speed]	Settings	[Auto] / [10 Mbps Full Duplex] / [10 Mbps Half Duplex] / [100 Mbps Full Duplex] / [100 Mbps Half Duplex] / [1 Gbps Full Duplex]
	Specifies the transmission speed for the network and the transmission method for bidirectional transmission.	
[IEEE802.1X]	Settings	[Enable] / [Disable]
	Select whether or not to enable IEEE802.1X.	
[Binary Division]	Settings	[ON] / [OFF]
	Select whether or not transmission data is divided.	
[S/MIME Comm.Setting]	Specify S/MIME communication settings.	
[S/MIME Enabled]	Settings	[Enable] / [Disable]
	Select whether or not to enable S/MIME.	
[Digital Signature]	Settings	[Always add signature] / [Do not add signature] / [Select when sending]
	Select the setting for digital signatures.	
[Encryption Method]	Settings	[RC2-40] / [RC2-64] / [RC2-128] / [DES] / [3DES] / [AES-128] / [AES-192] / [AES-256]
	Select the encryption method for the body of E-mail messages.	

[Auto. Obtain Certificates]	Settings	[Yes] / <b>[No]</b>
	Select whether or not to automatically obtain certificates.	
[Print S/MIME Information]	Settings	[Yes] / <b>[No]</b>
	Select whether or not to print S/MIME information.	

## [External Memory Print]

Description	
Settings	<b>[Enable]</b> / [Disable]
Select whether or not to enable the External Memory Print function.	

## [Job Timeout]

Description	
Settings	5 to 300(Default:15)
Specify the length of time until a job timeout occurs.	

## [Copy Settings]



*All factory default values are shown in bold.*

Item	Description	
[Specify Tray When APS OFF]	Settings	<b>[Tray Before APS ON]</b> / [Default Tray]
	Select which paper tray is selected when the automatic tray-switching feature (APS) is disabled.	
[Paper Priority]	Settings	[Tray 1] / <b>[Tray 2]</b> / [Tray 3] / [Tray 4]
	Specify the paper tray that is normally used.	
<i>[Tray3] and [Tray4] do not appear if the optional lower feeder units have not been installed.</i>		





## [Print Settings]



*All factory default values are shown in bold.*

Item	Description	
[Startup Page Setting]	Settings	[ON] / <b>[OFF]</b>
	Select whether or not a startup page is printed when the machine is turned on.	
[Auto Continue]	Settings	[ON] / <b>[OFF]</b>
	Select whether or not printing continues when a size error occurs during printing.	

[Paper]	Specify settings for the paper used for printing.	
[Default Paper]	Specify settings for the paper that is normally used.	
[Paper Size]	Settings	<b>[Letter]</b> / <b>[Legal]</b> / <b>[Executive]</b> / <b>[A4]</b> / <b>[A5]</b> / <b>[A6]</b> / <b>[B5 (JIS)]</b> / <b>[B6]</b> / <b>[Govt Letter]</b> / <b>[Statement]</b> / <b>[Folio]</b> / <b>[SP Folio]</b> / <b>[UK Quarto]</b> / <b>[Foolscap]</b> / <b>[Govt Legal]</b> / <b>[16K]</b> / <b>[4×6]</b> / <b>[Kai 16]</b> / <b>[Kai 32]</b> / <b>[Env C6]</b> / <b>[Env DL]</b> / <b>[Env Monarch]</b> / <b>[Env Chou#3]</b> / <b>[Env Chou#4]</b> / <b>[B5 (ISO)]</b> / <b>[Env#10]</b> / <b>[J Postcard]</b> / <b>[J Postcard-D]</b> / <b>[8 1/8×13 1/4]</b> / <b>[8 1/2×13 1/2]</b> / <b>[Custom Size]</b>
	Select the paper size.   <i>The default setting is [Letter] for USA and Canada, and [A4] for other countries.</i>   <i>Depending on the setting selected for [User Settings] - [Machine Settings] - [Measurement Unit Setting], 4 × 6 may change to 10 × 15 cm.</i>	
[Custom Size]	Press [Width] and [Length], and then type in the paper size.  Setting range for Width For inches: 3.63 to 8.50 inches For millimeters: 92 to 216 mm  Setting range for Length For inches: 5.83 to 14.00 inches For millimeters: 148 to 256 mm   <i>These settings can be specified if [Paper Size] is set to [Custom Size].</i>	
[Paper Type]	Settings	<b>[Plain Paper]</b> / <b>[Recycled]</b> / <b>[Thick 1]</b> / <b>[Thick 2]</b> / <b>[Label]</b> / <b>[Envelope]</b> / <b>[Postcard]</b> / <b>[Letterhead]</b> / <b>[Glossy 1]</b> / <b>[Glossy 2]</b> / <b>[1 Side Only]</b> / <b>[Special Paper]</b>
	Select the paper type.	

[Measurement Unit Setting]	Settings	[Inch] / [mm]
	Select the measurement units.	
[Hold Job Timeout]	Settings	[Disable] / [1 Hour] / [4 Hours] / [1 Day] / [1 Week]
	Specify the length of time until print jobs saved on the hard disk are deleted. If [Disable] is selected, print jobs are not deleted at a specific time.	
[Quality Settings]	Specify settings for the print quality.	
[Color Mode]	Settings	[Color Mode] / [Gray Scale]
	[Color Mode]: The pages are printed in full color. [Gray Scale]: The pages are printed in black and white.	
[Brightness]	Settings	-15 to 15% (Default: 0%)
	The brightness of the printed image can be adjusted.	
[Halftone]	Select how halftones in images, text and graphics are reproduced.	
[Image Printing]	Settings	[Line Art] / [Detail] / [Smooth]
	Select how halftones in images are reproduced. [Line Art]: Halftones are reproduced with high precision. [Detail]: Halftones are reproduced with detail. [Smooth]: Halftones are reproduced with smoothness.	
[Text Printing]	Settings	[Line Art] / [Detail] / [Smooth]
	Select how halftones in text are reproduced. [Line Art]: Halftones are reproduced with high precision. [Detail]: Halftones are reproduced with detail. [Smooth]: Halftones are reproduced with smoothness.	

[Graphics Printing]	Settings	[Line Art] / <b>[Detail]</b> / [Smooth] Select how halftones in graphics are reproduced. [Line Art]: Halftones are reproduced with high precision. [Detail]: Halftones are reproduced with detail. [Smooth]: Halftones are reproduced with smoothness.
[Edge Enhancement]	Select how edges in images, text and graphics are emphasized.	
[Image Printing]	Settings	[ON] / <b>[OFF]</b> Select whether image edges are emphasized. [ON]: The edges are emphasized. [OFF]: The edges are not emphasized.
[Text Printing]	Settings	<b>[ON]</b> / [OFF] Select whether text edges are emphasized. [ON]: The edges are emphasized. [OFF]: The edges are not emphasized.
[Graphics Printing]	Settings	<b>[ON]</b> / [OFF] Select whether graphics edges are emphasized. [ON]: The edges are emphasized. [OFF]: The edges are not emphasized.
[Edge Strength]	Settings	[OFF] / [Low] / <b>[Middle]</b> / [High] Select the desired amount that edges are emphasized. [OFF]: The edges are not emphasized. [Low]: The edges are slightly emphasized. [Middle]: The edges are emphasized by an average amount. [High]: The edges are highly emphasized.

[Economy Print]	Settings	[ON] / [OFF]  Select whether to print graphics with a reduced density by reducing the amount of toner that is used.  [ON]: The amount of toner used is reduced when printing.  [OFF]: The amount of toner used is not reduced when printing.
[PCL Settings]	Specify settings for PCL printing.	
[Contrast]	Settings	-15 to 15%(Default: 0%)  The contrast of the image can be adjusted.
[Image Printing]	Specify settings for RGB image data.	
[RGB Source]	Settings	[Device Color] / [sRGB]  Select the color space for RGB image data.  If [Device Color] is selected, no color space is specified.  RGB source profiles downloaded with Download Manager or Web Connection are available as RGB Source.
[RGB Intent]	Settings	[Vivid] / [Photographic]  Select the characteristic applied when converting RGB image data to CMYK data.  [Vivid]: A vivid output is produced.  [Photographic]: A brighter output is produced.
[RGB Gray]	Settings	[Bk=CMYK Gray=CMYK] / [Bk=K Gray=K] / [Bk=K Gray=CMYK]  Select how black and grays are reproduced in RGB image data.  [Bk=CMYK Gray=CMYK]: Black is reproduced using the CMYK colors.  [Bk=K Gray=K]: Black and gray are reproduced using black only.  [Bk=K Gray=CMYK]: Black is reproduced using only black.

[Text Printing]	Specify settings for RGB text data.	
[RGB Source]	Settings	[Device Color] / <b>[sRGB]</b>
	<p>Select the color space for RGB text data.</p> <p>If [Device Color] is selected, no color space is specified.</p> <p>RGB source profiles downloaded with Download Manager or Web Connection are available as RGB Source.</p>	
[RGB Intent]	Settings	<b>[Vivid]</b> / [Photographic]
	<p>Select the characteristic applied when converting RGB text data to CMYK data.</p> <p>[Vivid]: A vivid output is produced.</p> <p>[Photographic]: A brighter output is produced.</p>	
[RGB Gray]	Settings	[Bk=CMYK Gray=CMYK] / <b>[Bk=K Gray=K]</b> / [Bk=K Gray=CMYK]
	<p>Select how black and grays are reproduced in RGB text data.</p> <p>[Bk=CMYK Gray=CMYK]: Black is reproduced using the CMYK colors.</p> <p>[Bk=K Gray=K]: Black and gray are reproduced using black only.</p> <p>[Bk=K Gray=CMYK]: Black is reproduced using only black.</p>	
[Graphics Printing]	Specify settings for RGB graphics data.	
[RGB Source]	Settings	[Device Color] / <b>[sRGB]</b>
	<p>Select the color space for RGB graphics data.</p> <p>If [Device Color] is selected, no color space is specified.</p> <p>RGB source profiles downloaded with Download Manager or Web Connection are available as RGB Source.</p>	
[RGB Intent]	Settings	<b>[Vivid]</b> / [Photographic]
	<p>Select the characteristic applied when converting RGB graphics data to CMYK data.</p> <p>[Vivid]: A vivid output is produced.</p> <p>[Photographic]: A brighter output is produced.</p>	

[RGB Gray]	Settings	[Bk=CMYK Gray=CMYK] / [ <b>Bk=K Gray=K</b> ] / [Bk=K Gray=CMYK]  Select how black and grays are reproduced in RGB graphics data.  [Bk=CMYK Gray=CMYK]: Black is reproduced using the CMYK colors.  [Bk=K Gray=K]: Black and gray are reproduced using black only.  [Bk=K Gray=CMYK]: Black is reproduced using only black.
[PS Settings]		Specify settings for PostScript printing.
[Image Printing]		Specify settings for RGB image data.
[RGB Source]	Settings	[Device Color] / [ <b>sRGB</b> ] / [AppleRGB] / [AdobeRGB1998] / [ColorMatchRGB] / [BlueAdjustRGB]  Select the color space for RGB image data.  If [Device Color] is selected, no color space is specified.  RGB source profiles downloaded with Download Manager or Web Connection are available as RGB Source.
[RGB Intent]	Settings	[Vivid] / [ <b>Photographic</b> ] / [Relative Color] / [Absolute Color]  Select the characteristic applied when converting RGB image data to CMYK data.  [Vivid]: A vivid output is produced.  [Photographic]: A brighter output is produced.  [Relative Color]: Relative color is applied to the RGB source profile.  [Absolute Color]: Absolute color is applied to the RGB source profile.

[RGB Gray]	Settings	[Bk=CMYK Gray=CMYK] / <b>[Bk=K Gray=K]</b> / [Bk=K Gray=CMYK]  Select how black and grays are reproduced in RGB image data.  [Bk=CMYK Gray=CMYK]: Black is reproduced using the CMYK colors.  [Bk=K Gray=K]: Black and gray are reproduced using black only.  [Bk=K Gray=CMYK]: Black is reproduced using only black.
[Destination Profile]	Settings	<b>[Auto]</b>  Select the destination profile.  [Auto]: A destination profile that the machine automatically adapts is selected based on a combination of the specified color matching, halftones and other profiles.  Destination profiles downloaded with Download Manager or Web Connection are available as Destination Profile.
[Text Printing] Specify settings for RGB text data.		
[RGB Source]	Settings	[Device Color] / <b>[sRGB]</b> / [AppleRGB] / [AdobeRGB1998] / [ColorMatchRGB] / [BlueAdjustRGB]  Select the color space for RGB text data.  If [Device Color] is selected, no color space is specified.  RGB source profiles downloaded with Download Manager or Web Connection are available as RGB Source.



[RGB Intent]	Settings	<b>[Vivid]</b> / [Photographic] / [Relative Color] / [Absolute Color]
<p>Select the characteristic applied when converting RGB text data to CMYK data.</p> <p>[Vivid]: A vivid output is produced.</p> <p>[Photographic]: A brighter output is produced.</p> <p>[Relative Color]: Relative color is applied to the RGB source profile.</p> <p>[Absolute Color]: Absolute color is applied to the RGB source profile.</p>		
[RGB Gray]	Settings	<b>[Bk=CMYK Gray=CMYK]</b> / <b>[Bk=K Gray=K]</b> / [Bk=K Gray=CMYK]
<p>Select how black and grays are reproduced in RGB text data.</p> <p>[Bk=CMYK Gray=CMYK]: Black is reproduced using the CMYK colors.</p> <p>[Bk=K Gray=K]: Black and gray are reproduced using black only.</p> <p>[Bk=K Gray=CMYK]: Black is reproduced using only black.</p>		
[Destination Profile]	Settings	<b>[Auto]</b>
<p>Select the destination profile.</p> <p>[Auto]: A destination profile that the machine automatically adapts is selected based on a combination of the specified color matching, halftones and other profiles.</p> <p>Destination profiles downloaded with Download Manager or Web Connection are available as Destination Profile.</p>		

[Graphics Printing]	Specify settings for RGB graphics data.	
[RGB Source]	Settings	<p>[Device Color] / <b>[sRGB]</b> / [AppleRGB] / [AdobeRGB1998] / [ColorMatchRGB] / [BlueAdjustRGB]</p> <p>Select the color space for RGB graphics data.</p> <p>If [Device Color] is selected, no color space is specified.</p> <p>RGB source profiles downloaded with Download Manager or Web Connection are available as RGB Source.</p>
[RGB Intent]	Settings	<p><b>[Vivid]</b> / [Photographic] / [Relative Color] / [Absolute Color]</p> <p>Select the characteristic applied when converting RGB graphics data to CMYK data.</p> <p>[Vivid]: A vivid output is produced.</p> <p>[Photographic]: A brighter output is produced.</p> <p>[Relative Color]: Relative color is applied to the RGB source profile.</p> <p>[Absolute Color]: Absolute color is applied to the RGB source profile.</p>
[RGB Gray]	Settings	<p>[Bk=CMYK Gray=CMYK] / <b>[Bk=K Gray=K]</b> / [Bk=K Gray=CMYK]</p> <p>Select how black and grays are reproduced in RGB graphics data.</p> <p>[Bk=CMYK Gray=CMYK]: Black is reproduced using the CMYK colors.</p> <p>[Bk=K Gray=K]: Black and gray are reproduced using black only.</p> <p>[Bk=K Gray=CMYK]: Black is reproduced using only black.</p>

[Destination Profile]	Settings	<p><b>[Auto]</b></p> <p>Select the destination profile.</p> <p>[Auto]: A destination profile that the machine automatically adapts is selected based on a combination of the specified color matching, halftones and other profiles.</p> <p>Destination profiles downloaded with Download Manager or Web Connection are available as Destination Profile.</p>
[Simulation]		Specify settings for the simulation profile.
[Simulation Profile]	Settings	<p><b>[NONE]</b> / [SWOP] / [Euroscale] / [CommercialPress] / [JapanColor] / [TOYO] / [DIC]</p> <p>Select the simulation profile.</p> <p>If [NONE] is selected, no simulation profile is specified.</p> <p>Simulation profiles downloaded with Download Manager or Web Connection are available as Simulation Profile.</p>
[Sim. Intent]	Settings	<p><b>[Relative Color]</b> / [Absolute Color]</p> <p>Select the characteristic applied to the simulation profile.</p> <p>[Relative Color]: Relative color is applied to the simulation profile.</p> <p>[Absolute Color]: Absolute color is applied to the simulation profile.</p>
[CMYK Gray]	Settings	<p><b>[Bk=CMYK Gray=CMYK]</b> / [Bk=K Gray=K] / [Bk=K Gray=CMYK]</p> <p>Select how black and grays are reproduced using the four CMYK colors.</p> <p>[Bk=CMYK Gray=CMYK]: Black is reproduced using the CMYK colors.</p> <p>[Bk=K Gray=K]: Black and gray are reproduced using black only.</p> <p>[Bk=K Gray=CMYK]: Black is reproduced using only black.</p>

[Gradation Adjustment]	Specify settings for gradation level adjustments.	
[Tone Calibration]	Settings	[ON] / [OFF]
	[ON]: Image adjustments are applied. [OFF]: Image adjustments are not applied.	
[AIDC Process]	Settings	[Execute] / [Cancel]
	[Execute]: Image adjustments are performed immediately. [Cancel]: Image adjustments are not performed.	
	 <i>AIDC processing consumes toner.</i>	
[CMYK Density]	Specify fine adjustment settings for cyan, magenta, yellow and black.	
[Cyan]/ [Magenta]/ [Yellow]/ [Black]	Settings	-3 to 3 (Default: 0)
	[Highlight]: The density of the highlight color in images can be adjusted. [Middle]: The density of the middle color in images can be adjusted. [Shadow]: The density of the shadow color in images can be adjusted.	
[Color Separation]	Settings	[ON] / [OFF]
	[ON]: Color separation is performed. The contents of a color page is separated into the color pages for yellow, magenta, cyan and black, and each is printed with black gradations as individual pages. The printing order is yellow, magenta, cyan, then black. [OFF]: Color separation is not performed. A normal color separation is performed.	
[Emulation]	Specify the processing method for data received by this machine.	
[Default Emulation]	Settings	[Auto] / [PS] / [PCL]
	Select the machine emulation language. If [Auto] is selected, the machine automatically selects the machine emulation language from the data stream.	

[PS]	Specify settings for PostScript errors and data transmissions.	
[Wait Timeout]	Settings	0 to 300 (Default: <b>0</b> )
	Specify the time until an error is determined to be a PostScript error.  If [0] is selected, no timeout is performed.	
[Print PS Errors]	Settings	[ON] / [OFF]
	Select whether or not an error page is printed when a Postscript error occurs.	
[PS Protocol]	Settings	[Auto] / [Normal] / [Binary]
	Select the protocol for data transmissions with a PostScript data stream.  If [Auto] is selected, the machine automatically selects an applicable protocol from the data stream.	
[Auto Trapping]	Settings	[ON] / [OFF]
	Select whether or not neighboring colors are printed superimposed in order to prevent white space around images.	
[Black Overprint]	Settings	[Text/Graphic] / [Text] / [OFF]
	Specify whether black objects are printed (superimposed) on a neighboring color in order to prevent white space around black characters or figures.  If [Text/Graphic] is selected, superimposed printing is applied to text and graphics.  If [Text] is selected, superimposed printing is applied to text.	
[PCL]	Specify settings for the PCL language.	
[CR/LF Mapping]	Settings	[CR = CR LF = LF] / [CR = CRLF LF = LF] / [CR = CR LF = LF CR] / [CR = CRLF LF = LF CR]
	Select the definitions of the CR/LF codes in the PCL language.	
[Line/Page]	Settings	5 to 128 (Default: <b>60</b> )
	Specify the number of lines per page in the PCL language.	

[Font Setting]	Specify font settings for the PCL language.	
[Font Number]	Settings	0 to 102 (Default: <b>000</b> )
	Specify the default font in the PCL language.  The font numbers that appear correspond to the PCL font list.  For details on printing the font list, refer to “[Print Settings]” on page 3-17.	
[Pitch Size]	Settings	0.44 to 99.99 (Default: <b>10.00</b> )
	Specify the font size in the PCL language.  If the setting selected for [Font Number] is for a bitmap font, [Pitch Size] appears. If the setting selected for [Font Number] is for an outline font, [Point Size] appears.	
[Symbol Set]	Settings	<b>[PC8]</b> / [Desktop] / [IOS4] / [ISO6] / [ISO11] / [ISO15] / [ISO17] / [ISO21] / [ISO60] / [ISO69] / [ISOL1] / [ISOL2] / [ISOL5] / [ISOL6] / [ISOL9] / [Legal] / [Math8] / [MCText] / [MSPUBL] / [PC775] / [PC850] / [PC852] / [PC858] / [PC8DN] / [PC8TK] / [PC1004] / [Pi Font] / [PS math] / [PS Text] / [Roman 8] / [WIN30] / [WIN Balt] / [WINL1] / [WINL2] / [WINL5] / [ARABIC8] / [HPWARA] / [PC864ARA] / [HEBREW7] / [HEBREW8] / [ISOHEB] / [PC862HEB] / [ISOCYR] / [PC866CYR] / [WINCYR] / [PC866UKR] / [Greek 8] / [WIN-GRK] / [PC851GRK] / [PC8GRK] / [ISOGRK]
	Specify the symbol set used with the PCL language.	

[XPS]	Specify XPS settings.	
[Digital Signature]	Settings	[Enable] / <b>[Disable]</b>
	Select whether or not to enable XPS digital signatures. [Enable]: XPS digital signatures are enabled. [Disable]: XPS digital signatures are disabled.	
[Print XPS Errors]	Settings	<b>[ON]</b> / [OFF]
	Select whether or not an error report is printed after an XPS error has occurred. [ON]: The error report is printed. [OFF]: The error report is not printed.	

## [Fax Settings]

Specify the fax settings. For details on specifying the fax settings, refer to the [Facsimile User's Guide].

## [Maintenance Menu]



*All factory default values are shown in bold.*

Item	Description	
[Print Menu]	Specify settings for printing event logs and graduations.	
[Event Log]	Settings	<b>[Print]</b> / [Cancel]
	Prints the event log.	
[Halftone 64]	Settings	<b>[Print]</b> / [Cancel]
	Prints the halftone pattern using a 25% density for each CMYK color.	
[Cyan 64]/ [Magenta 64]/ [Yellow 64]/ [Black 64]		
[Halftone 128]	Settings	<b>[Print]</b> / [Cancel]
	Prints the halftone pattern using a 50% density for each CMYK color.	
[Cyan 128]/ [Magenta 128]/ [Yellow 128]/ [Black 128]		

[Halftone 256]	Settings	[Print] / [Cancel]
	Prints the halftone pattern using a 100% density for each CMYK color.	
[Cyan 256]/ [Magenta 256]/ [Yellow 256]/ [Black 256]		
[Gradation]	Settings	[Print] / [Cancel]
	Prints the gradation pattern.	
[Activity Report]	Settings	[Print] / [Cancel]
	Prints the communications activity report.	
[Scan Send Report Print]	Settings	[Print] / [Cancel]
	Prints the scanning operations activity report.	
[Scan Event Log]	Settings	[Print] / [Cancel]
	Prints the scanning event log.	
[Printer Adjustment]	Specify various machine adjustments.	
[Leading Edge Adjustment]	Adjust the top margin for various types of media.	
	[Plain Paper]	Settings -15 to 15
	Adjust the top margin of plain paper for simplex (single-sided) printing.	
[Thick 1]	Settings	-15 to 15
	Adjust the top margin of thick paper for simplex (single-sided) printing.	
[Thick 2]	Settings	-15 to 15
	Adjust the top margin of Thick 2 paper for simplex (single-sided) printing.	
[Envelope]	Settings	-15 to 15
	Adjust the top margin of envelopes for simplex (single-sided) printing.	
[Side Edge Adjustment]	Adjust the left margin for media fed from each paper tray.	
[Tray1]	Settings	-15 to 15
	Adjust the left margin of media fed from Tray 1 for simplex (single-sided) printing.	



[Tray2]	Settings	-15 to 15
	Adjust the left margin of media fed from Tray 2 for simplex (single-sided) printing.	
[Tray3]	Settings	-15 to 15
	Adjust the left margin of media fed from Tray 3 for simplex (single-sided) printing.	
[Tray4]	Settings	-15 to 15
	Adjust the left margin of media fed from Tray 4 for simplex (single-sided) printing.	
[Left ADJ Duplex]	Adjust the left margin for media fed from each paper tray with duplex (double-sided) printing.	
[Tray1]	Settings	-15 to 15
	Adjust the left margin of media fed from Tray 1 for duplex (double-sided) printing.	
[Tray2]	Settings	-15 to 15
	Adjust the left margin of media fed from Tray 2 for duplex (double-sided) printing.	
[Tray3]	Settings	-15 to 15
	Adjust the left margin of media fed from Tray 3 for duplex (double-sided) printing.	
[Tray4]	Settings	-15 to 15
	Adjust the left margin of media fed from Tray 4 for duplex (double-sided) printing.	
[2nd Image Transfer Current]	Adjust the 2nd image transfer current.	
[Simplex Pass]	Adjust the 2nd image transfer output (ATVC) for simplex (single-sided) printing.	
[Plain Paper]	Settings	-8 to 7
	Adjust the 2nd image transfer output (ATVC) for simplex (single-sided) printing of plain paper.	
[Thick 1]	Settings	-8 to 7
	Adjust the 2nd image transfer output (ATVC) for simplex (single-sided) printing of Thick 1 paper.	

[Thick 2]	Settings	-8 to 7
	Adjust the 2nd image transfer output (ATVC) for simplex (single-sided) printing of Thick 2 paper.	
[Postcard]	Settings	-8 to 7
	Adjust the 2nd image transfer output (ATVC) for simplex (single-sided) printing of postcards.	
[Envelope]	Settings	-8 to 7
	Adjust the 2nd image transfer output (ATVC) for simplex (single-sided) printing of envelopes.	
[Label]	Settings	-8 to 7
	Adjust the 2nd image transfer output (ATVC) for simplex (single-sided) printing of labels.	
[Glossy 1]	Settings	-8 to 7
	Adjust the 2nd image transfer output (ATVC) for simplex (single-sided) printing of Glossy 1 media.	
[Glossy 2]	Settings	-8 to 7
	Adjust the 2nd image transfer output (ATVC) for simplex (single-sided) printing of Glossy 2 media.	
[Manual Duplex]	Adjust the 2nd image transfer output (ATVC) for duplex (double-sided) printing.	
[Plain Paper]	Settings	-8 to 7
	Adjust the 2nd image transfer output (ATVC) for printing on the back side of plain paper that has already been printed on.	
[Thick 1]	Settings	-8 to 7
	Adjust the 2nd image transfer output (ATVC) for printing on the back side of Thick 1 paper that has already been printed on.	
[Thick 2]	Settings	-8 to 7
	Adjust the 2nd image transfer output (ATVC) for printing on the back side of Thick 2 paper that has already been printed on.	

[Postcard]	Settings	-8 to 7
	Adjust the 2nd image transfer output (ATVC) for printing on the back side of postcards that has already been printed on.	
[Envelope]	Settings	-8 to 7
	Adjust the 2nd image transfer output (ATVC) for printing on the back side of envelopes that has already been printed on.	
[Label]	Settings	-8 to 7
	Adjust the 2nd image transfer output (ATVC) for printing on the back side of labels that has already been printed on.	
[Glossy 1]	Settings	-8 to 7
	Adjust the 2nd image transfer output (ATVC) for printing on the back side of Glossy 1 media that has already been printed on.	
[Glossy 2]	Settings	-8 to 7
	Adjust the 2nd image transfer output (ATVC) for printing on the back side of Glossy 2 media that has already been printed on.	
[Thick Paper Image Density]	Adjust the density of images printed on thick paper.	
[Cyan]	Settings	-5 to 5 (Default: <b>0</b> )
	Finely adjust the density of cyan for images printed on thick paper.	
[Magenta]	Settings	-5 to 5 (Default: <b>0</b> )
	Finely adjust the density of magenta for images printed on thick paper.	
[Yellow]	Settings	-5 to 5 (Default: <b>0</b> )
	Finely adjust the density of yellow for images printed on thick paper.	
[Black]	Settings	-5 to 5 (Default: <b>0</b> )
	Finely adjust the density of black for images printed on thick paper.	
[Monochrome Density Adj.]	Settings	-2 to 2 (Default: <b>0</b> )
	Finely adjust the density of printed images with grayscale printing.	

[Fine Line ADJ]	Settings	-3 to 2 (Default: <b>0</b> )
	Adjust how fine lines are reproduced by changing the applied voltage (VC) to the electrostatic roller.	
[AIDC Mode]	Settings	[Mode 1] / <b>[Mode 2]</b>
	Select the AIDC operation mode.  [Mode 1]: Standard mode [Mode 2]: Low mode	
[Thick Mode]	Settings	<b>[Quality Mode]</b> / [Speed Mode]
	<p>In order to prevent toner from clogging within the developer unit as a result of it being driven at half-speed, select the timing for driving the developer unit at full speed for a fixed length of time when thick paper is being fed.</p> <p>[Quality Mode]: While printing on thick paper, printing is periodically paused, and the developer unit is driven at full speed for a fixed length of time. Since printing is paused, the quality is not affected; however, a standby time of approximately 70 seconds occurs every 400 seconds or so of half-speed operation.</p> <p>[Speed Mode]: While printing on thick paper, only the drive of the developer unit periodically switches to full speed for a fixed length of time. Since printing continues during full-speed drive, the print quality is slightly affected, however the standby time is short.</p>	
[Engine DipSW]	Change the DIP switches to control machine operation.	
[Engine DipSW 1] - [Engine DipSW 28]	Settings	[ON] / <b>[OFF]</b>
	Use to change engine settings.   <i>Normally, there is no need to change the settings. If it becomes necessary to change the settings, do so according to the instructions from the service representative.</i>	

[Main Scan Adjust]	Adjust the scanning settings.	
[Main Scan Page]	Settings	<b>[Print]</b> / [Cancel]
	Print the test pattern for fine adjustment of the color ratios in the main scanning direction.	
[Scan Adjust Value]	Specify color adjustments for yellow, magenta and cyan.	
[Yellow]	Settings	-42 to 42 (Default: <b>0</b> )
	Finely adjust the ratio of yellow in the main scanning direction.	
[Magenta]	Settings	-42 to 42 (Default: <b>0</b> )
	Finely adjust the ratio of magenta in the main scanning direction.	
[Cyan]	Settings	-42 to 42 (Default: <b>0</b> )
	Finely adjust the ratio of cyan in the main scanning direction.	
[Supplies]	Reset the service life counters for various consumables.	
[Consumables Replace]		
[Transfer Belt Unit]	Settings	[Yes] / <b>[No]</b>
	Reset the transfer belt counter.	
[Transfer Roller Unit]	Settings	[Yes] / <b>[No]</b>
	Reset the transfer roller counter.	
[Fusing Unit]	Settings	[Yes] / <b>[No]</b>
	Reset the fuser unit counter.	

## [Folder Settings]



*All factory default values are shown in bold.*



Item	Description	
[Auto Del Interval]	Settings	<b>[Erase Disabled]</b> / [12 Hours] / [1 Day] / [2 Days] / [3 Days] / [7 Days] / [30 Days]
	Select the length of time until files saved on the hard disk are automatically deleted.	

[Auto Document Delete Time]	Settings	[Erase Disabled] / [12 Hours] / [ <b>1 Day</b> ] / [2 Days] / [3 Days] / [7 Days] / [30 Days]
	Select the length of time that files are saved on the hard disk.	
[Document Hold Setting]	Settings	[Enable] / [ <b>Disable</b> ]
	Select whether or not a file is deleted after it is retrieved.	

## [Security Settings]









*All factory default values are shown in bold.*

Item	Description	
[Administrator Password]	Settings	[ <b>12345678</b> ]
	<p>Change the administrator password.</p> <p>Specify the administrator password as a 0 to 8 digit number.</p> <p> <i>If password rules have been applied, an 8-digit password must be specified.</i></p> <p> <i>If the administrator password is incorrectly entered three times, machine operations are locked. If this occurs, turn the machine off, then on again.</i></p> <p>[Password] (top): Type in the current password.</p> <p>[Password] (bottom): Type in the new password.</p>	
[Security Details]	Specify detailed security settings to limit machine functions. Security can be enhanced if machine functions are limited.	
[Password Rules]	Settings	[ON] / [ <b>OFF</b> ]
	Select whether or not password rules are applied.	
[Registering and Changing Addr.]	Settings	[ <b>Allow</b> ] / [Restrict]
	Select whether or not to prohibit editing of the address book. If [Restrict] is selected, the address book cannot be edited.	

[Manual Destination Input]	Settings	[ <b>Allow</b> ] / [ <b>Restrict</b> ]
	Select whether or not to prohibit manual input of a destination. If [ <b>Restrict</b> ] is selected, destinations for fax and scan operations cannot be entered directly.	
[Hide Personal Data]	Settings	[ <b>ON</b> ] / [ <b>OFF</b> ]
	Select whether or not to display transmission destinations in the job log. If [ <b>ON</b> ] is selected, transmission destinations are not displayed.	
[Disable Job History Display]	Settings	[ <b>ON</b> ] / [ <b>OFF</b> ]
	Select whether or not to display the communication log. If [ <b>ON</b> ] is selected, the communication log is not displayed.	
[Restrict Scan to USB]	Settings	[ <b>Allow</b> ] / [ <b>Restrict</b> ]
	Select whether or not to prohibit the Scan to USB function. If [ <b>Restrict</b> ] is selected, the Scan to USB function cannot be used.	
[Enhanced Security Mode]	Settings	[ <b>ON</b> ] / [ <b>OFF</b> ]
	Select whether or not to apply enhanced security settings. If [ <b>ON</b> ] is selected, the enhanced security settings are applied.	
[HDD Settings]	Check the capacity of the hard disk or delete data by overwriting.	
[Check HDD Capacity]	Check the total capacity of the hard disk, the amount of space used and the amount of space available.	
[Overwrite All Data]	Delete all data on the hard disk by overwriting it.	

[Mode]	Settings	<b>[Mode 1]</b> / [Mode 2] / [Mode 3] / [Mode 4] / [Mode 5] / [Mode 6] / [Mode 7] / [Mode 8]
<p>Select the method for overwriting the data on the hard disk.</p> <p>[Mode 1]: Overwritten with 0x00</p> <p>[Mode 2]: Overwritten with 1-byte random numbers → Overwritten with 1-byte random numbers → Overwritten with 0x00</p> <p>[Mode 3]: Overwritten with 0x00 → Overwritten with 0xff → Overwritten with 1-byte random numbers → Verified</p> <p>[Mode 4]: Overwritten with 1-byte random numbers → Overwritten with 0x00 → Overwritten with 0xff</p> <p>[Mode 5]: Overwritten with 0x00 → Overwritten with 0xff → Overwritten with 0x00 → Overwritten with 0xff</p> <p>[Mode 6]: Overwritten with 0x00 → Overwritten with 0xff → Overwritten with 0x00 → Overwritten with 0xff → Overwritten with 0x00 → Overwritten with 0xff → Overwritten with specified 512-byte data</p> <p>[Mode 7]: Overwritten with 0x00 → Overwritten with 0xff → Overwritten with 0x00 → Overwritten with 0xff → Overwritten with 0x00 → Overwritten with 0xff → Overwritten with 0xaa</p> <p>[Mode 8]: Overwritten with 0x00 → Overwritten with 0xff → Overwritten with 0x00 → Overwritten with 0xff → Overwritten with 0x00 → Overwritten with 0xff → Overwritten with 0xaa → Verified</p>		



	[Execute]	<p>Press to delete all data on the hard disk by overwriting it, and then press [OK].</p> <p> <i>Perform this operation when disposing of this machine.</i></p> <p> <i>While the data is being deleted by being overwritten, do not use the power switch to turn the machine off and on.</i></p> <p> <i>After the machine is restarted, all data is deleted by being overwritten.</i></p> <p>The following data is deleted.</p> <ul style="list-style-type: none"> <li>- Registered user and account data</li> <li>- Registered information for secured printing and saved files</li> <li>- Image files</li> </ul>
	[SSD Low-level Format]	<p>Press to delete all data on the SSD by overwriting it, and then press [OK].</p> <p> <i>Perform this operation when disposing of this machine.</i></p> <p> <i>While the data is being deleted by being overwritten, do not use the power switch to turn the machine off and on.</i></p> <p> <i>After the machine is restarted, all data is deleted by being overwritten.</i></p> <p>The following data is deleted.</p> <ul style="list-style-type: none"> <li>- Sent and received fax data</li> <li>- Address book (E-mail address and telephone number destination data)</li> <li>- S/MIME certificates</li> <li>- Image files</li> </ul>

## Changing the administrator password

The following procedure describes how to change the administrator password.

- 1 Press [Administrator Password].
- 2 Press [Password] (top).
- 3 Type in the current administrator password, and then press [OK].
- 4 Press [Password] (bottom).
- 5 Type in the new administrator password, and then press [OK].
- 6 Press [OK].

## Limitations of the password rules

If password rules have been applied, limitations are placed on certain passwords. Specified passwords must be changed to meet the conditions.

## Passwords regulated by the password rules

- Administrator password
- User passwords
- Account passwords
- Passwords for secure documents

## Conditions of the password rules

- Specify a password of 8 or more digits.
- Uppercase and lowercase letters are differentiated.
- Half-width symbols are used. The use of symbols such as the quotation mark ("), plus sign (+) and spaces are limited with some settings.
- A password that consists of a repetition of the same character cannot be specified.
- When changing the password, the same password as that before it is changed cannot be specified.

## Enhanced security settings

If settings have been specified that are incompatible with the enhanced security settings, the enhanced security settings cannot be applied.

The settings that must be specified or are forcibly set cannot be changed after the enhanced security settings have been applied.

## Required settings

The following settings must first be specified in order to apply the enhanced security settings.

Administrator mode parameters	Required settings
[Security Settings] - [Administrator Password]	Specify a password that meets the conditions of the password rules.
[Security] tab in Web Connection - [Authentication Setting] - [General Settings] - [User Authentication]	Select [Device] or [External Server].
[Security] tab in Web Connection - [PKI Settings] - [Device Certificate]	Register a self-signed certificate in order to perform SSL communications.
[Network] tab in Web Connection - [SNMP Settings] - [SNMP v3 Settings] - [auth-password]	Specify passwords for [auth-password] and [priv-password] that meet the conditions of the password rules.
[SSL] in Web Connection	Select [AES-256] or [AES-256, 3DES-168].
[S/MIME] in Web Connection	Select [3DES], [AES-128], [AES-192] or [AES-256].

## Changed settings

For increased security, the following settings are set when enhanced security settings are applied.



*A changed setting cannot be changed when [Enhanced Security Mode] is set to [OFF].*



*If password rules have been applied, a password that does not meet the conditions of the password rules is considered a failed attempt during authentication.*

Administrator mode parameters	Changed settings
[Security Settings] - [Security Details] - [Password Rules]	Set to [ON].
[Security] tab in Web Connection - [Authentication Setting] - [General Settings] - [Public Access]	Set to [Restrict].
[Security] tab in Web Connection - [PKI Settings] - [SSL/TLS Settings] - [SSL/TLS]	Set to [Enable].
[Security] tab in Web Connection - [PKI Settings] - [SSL/TLS Settings] - [Encryption Strength]	Set to [AES-256] or [AES-256, 3DES-168]. <sup>*1</sup>
[Network] tab in Web Connection - [E-mail Settings] - [S/MIME] - [E-mail Text Encryption Method]	Set to [3DES], [AES-128], [AES-192] or [AES-256]. <sup>*1</sup>
[Network] tab in Web Connection - [FTP Settings] - [FTP Server Settings] - [FTP Server]	Set to [Disable].
[Network] tab in Web Connection - [SNMP Settings] - [SNMP v1/v2c Set- tings] - [Write]	Set to [Disable].
[Network] tab in Web Connection - [SNMP Settings] - [SNMP v3 Set- tings] - [Write User Name] - [Security Level], [auth-password] and [priv-password]	Set to [Auth-password/Priv-pass- word].
[Security Settings] - [Security Details] - [Registering and Changing Addr.]	Set to [Restrict].

<sup>\*1</sup> Set to [AES/3DES] when [Enhanced Security Mode] is set to [OFF].

## [Restore Defaults]

Item	Description
[Restore Network]	Resets the network settings to their defaults. After this is pressed, the printer is automatically restarted.
[Restore System]	Resets the system settings to their defaults. After this is pressed, the printer is automatically restarted.
[Restore All]	Resets all settings to their defaults. After this is pressed, the printer is automatically restarted.

## [HDD Format]

Item	Description
[User Area (Print)]	Initializes the user area (printing) of the hard disk.  After the reformatting operation is finished, turn the machine off, then on again.
[User Area (Scan)]	Initializes the user area (scanning) of the hard disk.  After the reformatting operation is finished, turn the machine off, then on again.
[All]	Initializes the hard disk.  After the reformatting operation is finished, turn the machine off, then on again.

## [Paper Empty]



All factory default values are shown in bold.

Item	Description
[Tray 1]	Settings   <b>[ON]</b> / <b>[OFF]</b>
	Select whether or not a message appears when Tray 1 has run out of paper.
[Tray 2]	Settings   <b>[ON]</b> / <b>[OFF]</b>
	Select whether or not a message appears when Tray 2 has run out of paper.
[Tray 3]	Settings   <b>[ON]</b> / <b>[OFF]</b>
	Select whether or not a message appears when Tray 3 has run out of paper.
[Tray 4]	Settings   <b>[ON]</b> / <b>[OFF]</b>
	Select whether or not a message appears when Tray 4 has run out of paper.

## [Restriction Code Settings]

Item	Description
Restriction Code Settings	Displays the list of inhibited codes of the OpenAPI connection applications.  [New]: Registers new inhibited codes for the Index Code, Vendor Code, and Application Code.

## [Erase Job Log]

Item	Description
Erase Job Log	If [OK] is selected, Accounting Log, Counting Log and Audit Log are deleted.

# *Media Handling* **4**



## Specifications

Media	Media Size		Tray*	Duplex	Copy	Scan	FAX
	Inch	Millimeter					
Letter	8.5 × 11.0	215.9 × 279.4	1/2/3/4	Yes	Yes	Yes	Yes
Letter Plus	8.5 × 12.69	215.9 × 322.3	1/2	Yes	Yes	Yes	No
Government letter	8.0 × 10.5	203.2 × 266.7	1/2	Yes	Yes	Yes	No
Legal	8.5 × 14.0	215.9 × 355.6	1/2/3/4	Yes	Yes	Yes	Yes
Executive	7.25 × 10.5	184.2 × 266.7	1/2/3/4	Yes	Yes	Yes	No
Statement	5.5 × 8.5	139.7 × 215.9	1/2	No	Yes	Yes	No
16 K	7.7 × 10.6	195.0 × 270.0	1/2	Yes	Yes	Yes	No
UK Quarto	8.0 × 10.0	203.2 × 254.0	1/2	Yes	Yes	Yes	No
Foolscap	8.0 × 13.0	203.2 × 330.2	1/2	Yes	Yes	Yes	No
Government Legal	8.5 × 13.0	215.9 × 330.2	1/2/3/4	Yes	Yes	Yes	No
Folio	8.25 × 13.0	210.0 × 330.0	1/2	Yes	Yes	Yes	No
8 1/2 × 13 1/2	8.5 × 13.5	215.9 × 342.9	1/2	Yes	Yes	Yes	Yes
8 1/8 × 13 1/4	8.125 × 13.25	206.4 × 336.6	1/2	Yes	Yes	Yes	No
A4	8.2 × 11.7	210.0 × 297.0	1/2/3/4	Yes	Yes	Yes	Yes
A5	5.9 × 8.3	148.0 × 210.0	1/2	No	Yes	Yes	No
B5 (JIS)	7.2 × 10.1	182.0 × 257.0	1/2/3/4	Yes	Yes	Yes	No
A6	4.1 × 5.8	105.0 × 148.0	1/2	No	Yes**	Yes**	No
B6	5.0 × 7.2	128.0 × 182.0	1/2	No	Yes**	Yes**	No
Photo size 4 × 6"	4.0 × 6.0	101.6 × 152.4	1/2	No	Yes**	Yes**	No
Photo size 10 × 15	4.0 × 6.0	101.6 × 152.4	1/2	No	Yes**	Yes**	No
Photo size E size	3.2 × 4.6	82.5 × 117.0	-	No	Yes**	Yes**	No
Photo size L size	3.5 × 5.0	89.0 × 127.0	-	No	Yes**	Yes**	No
Photo size 9 × 13	3.5 × 5.1	90.0 × 130.0	-	No	Yes**	Yes**	No
Photo size 13 × 18	5.1 × 7.1	130.0 × 180.0	-	No	Yes**	Yes**	No
Photo size 3 × 5"	3.0 × 5.0	76.2 × 127.0	-	No	Yes**	Yes**	No
Photo size 2 1/4 × 3 1/4"	2.25 × 3.29	57.1 × 82.5	-	No	Yes**	Yes**	No
J-Postcard	3.9 × 5.8	100.0 × 148.0	1/2	No	Yes**	Yes**	No
Double Postcard	5.8 × 7.9	148.0 × 200.0	1/2	No	Yes	Yes	No
B5 (ISO)	6.9 × 9.8	176.0 × 250.0	1	No	Yes	Yes	No
Envelope Com10	4.125 × 9.5	104.8 × 241.3	1	No	No	No	No
Envelope Monarch	7.5 × 3.875	190.5 × 98.4	1	No	No	No	No



Media	Media Size		Tray*	Duplex	Copy	Scan	FAX
	Inch	Millimeter					
Envelope You #6	7.5 × 3.875	190.5 × 98.4	1	No	No	No	No
Envelope DL	8.7 × 4.3	220.0 × 110.0	1	No	No	No	No
Envelope C6	6.4 × 4.5	162.0 × 114.0	1	No	No	No	No
Envelope You #2	6.4 × 4.5	162.0 × 114.0	1	No	No	No	No
Envelope Chou #3	4.7 × 9.2	120.0 × 235.0	1	No	No	No	No
Envelope Chou #4	3.5 × 8.1	90.0 × 205.0	1	No	No	No	No
Kai 16	7.3 × 10.2	185.0 × 260.0	1/2	Yes	Yes	Yes	No
Kai 32	5.1 × 7.3	130.0 × 185.0	1/2	No	Yes**	Yes**	No
Custom, Minimum	3.6 - 8.5 × 5.8 - 14.0	92.0 - 216.0 × 148.0 - 356.0	1/2***	Yes****	Yes	Yes	Yes
Custom, Maximum	7.2 - 8.5 × 10.0 - 14.0	182.0 - 216.0 × 254.0 - 356.0	1/2	Yes	No	No	No
<b>Notes:</b>	*Tray 1 = Multipurpose Tray 3/4 = Plain paper only **Original glass only ***Numerical value input ****Only a size within the range 182.0 - 216.0 × 254.0 - 356.0 is allowed.						

## Types



*Keep media on a flat, level surface in its original wrapper until it is time to load it.*



*Before printing a large number of copies on special paper (other than plain paper), perform a trial print to check the quality of the print result.*

### Plain Paper (Recycled Paper)

<b>Capacity</b>	<b>Tray 1</b>	Up to 100 sheets, depending on the media weight
	<b>Tray 2</b>	Up to 250 sheets, depending on the media weight
	<b>Tray 3/4</b>	Up to 500 sheets, depending on the media weight
<b>Orientation</b>	<b>Tray 1</b>	Face down
	<b>Tray 2/3/4</b>	Face up
<b>Driver Media Type</b>	Plain Paper (Recycled)	
<b>Weight</b>	60 to 90 g/m <sup>2</sup>	
<b>Duplexing</b>	Refer to “Specifications” on page 4-2.	

#### Use plain paper that is

- Suitable for plain paper printers and copiers, such as standard or recycled office paper.

#### DO NOT use media that is

- Coated with a processed surface (such as carbon paper and colored paper that has been treated)
- Unapproved iron-on transfer media (such as heat-pressure paper, and heat-press transfer paper)
- Cold-water-transfer paper
- Pressure sensitive
- Designed specifically for inkjet printers (such as superfine paper, glossy film, and postcards)
- Already been printed on by another printer, copier, or fax machine
- Dusty
- Wet (or damp)



*Keep media between 15% and 85% relative humidity. Toner does not adhere well to moist or wet media.*

- Layered
- Adhesive
- Folded, creased, curled, embossed, warped, or wrinkled
- Perforated, three-hole punched, or torn
- Too slick, too coarse, or too textured
- Different in texture (roughness) on the front and back
- Too thin or too thick
- Stuck together with static electricity
- Composed of foil or gilt; too luminous
- Heat sensitive or cannot withstand the fusing temperature (180°C [356°F])
- Irregularly shaped (not rectangular or not cut at right angles)
- Attached with glue, tape, paper clips, staples, ribbons, hooks, or buttons
- Acidic
- Any other media that is not approved

## Thick Stock

Paper thicker than 90 g/m<sup>2</sup> (24 lb bond) is referred to as thick stock.

You can print continuously with thick stock. However, this could affect the media feed, depending on the media quality and printing environment. If problems occur, stop the continuous printing and print one sheet at a time.

<b>Capacity</b>	<b>Tray 1/2</b>	Up to 20 sheets, depending on their thickness
	<b>Tray 3/4</b>	Not supported
<b>Orientation</b>	<b>Tray 1</b>	Face down
	<b>Tray 2</b>	Face up
<b>Driver Media Type</b>	Thick 1 (91–150 g/m <sup>2</sup> ) Thick 2 (151–210 g/m <sup>2</sup> )	
<b>Weight</b>	91 to 210 g/m <sup>2</sup>	
<b>Duplexing</b>	Refer to “Specifications” on page 4-2.	

## Envelope

Print on the front (address) side only. Some parts of the envelope consist of three layers of paper—the front, back, and flap. Anything printed in these layered regions may be lost or faded.

You can print continuously with envelope. However, this could affect the media feed, depending on the media quality and printing environment. If problems occur, stop the continuous printing and print one sheet at a time.

<b>Capacity</b>	<b>Tray 1</b>	Up to 10 sheets, depending on their thickness
	<b>Tray 2/3/4</b>	Not supported
<b>Orientation</b>	Face down	
<b>Driver Media Type</b>	Envelope	
<b>Duplexing</b>	Not supported	

### Use envelopes that are

- Common office envelopes approved for laser printing with diagonal joints, sharp folds and edges, and ordinary gummed flaps



*Because the envelopes pass through heated rollers, the gummed area on the flaps may seal. Using envelopes with emulsion-based glue avoids this problem.*

- Approved for laser printing
- Dry

### DO NOT use envelopes that have

- Sticky flaps
- Tape seals, metal clasps, paper clips, fasteners, or peel-off strips for sealing
- Transparent windows
- Too rough of a surface
- Material that will melt, vaporize, offset, discolor, or emit dangerous fumes
- Been presealed

## Label

A sheet of labels consists of a face sheet (the printing surface), adhesive, and a carrier sheet:

- The face sheet must follow the plain paper specification.
- The face sheet surface must cover the entire carrier sheet, and no adhesive should come through on the surface.

You can print continuously with label sheets. However, this could affect the media feed, depending on the media quality and printing environment. If problems occur, stop the continuous printing and print one sheet at a time.

Check your application documentation for more information on printing labels.

<b>Capacity</b>	<b>Tray 1/2</b>	Up to 20 sheets, depending on their thickness
	<b>Tray 3/4</b>	Not supported
<b>Orientation</b>	<b>Tray 1</b>	Face down
	<b>Tray 2</b>	Face up
<b>Driver Media Type</b>	Label	
<b>Duplexing</b>	Not supported	

### Use label sheets that are

- Recommended for laser printing

### DO NOT use label sheets that

- Have labels that easily peel off or have parts of the label already removed
- Have backing sheets that have peeled away or have exposed adhesive



*Labels may stick to the fuser, causing them to peel off and media misfeeds to occur.*

- Are precut or perforated

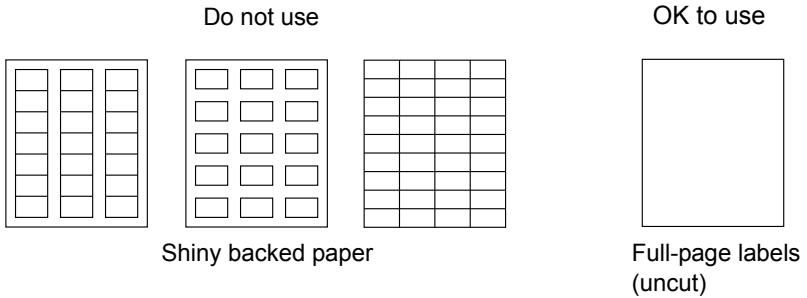

## Letterhead

You can print continuously with letterhead. However, this could affect the media feed, depending on the media quality and printing environment. If problems occur, stop the continuous printing and print one sheet at a time.

Check your application documentation for more information on printing letterhead.

<b>Capacity</b>	<b>Tray 1/2</b>	Up to 20 sheets, depending on their size and thickness
	<b>Tray 3/4</b>	Not supported
<b>Orientation</b>	<b>Tray 1</b>	Face down
	<b>Tray 2</b>	Face up
<b>Driver Media Type</b>	Letterhead	
<b>Duplexing</b>	Not supported	

## Postcard

You can print continuously with postcard. However, this could affect the media feed, depending on the media quality and printing environment. If problems occur, stop the continuous printing and print one sheet at a time.

Check your application documentation for more information on printing postcards.

<b>Capacity</b>	<b>Tray 1/2</b>	Up to 20 sheets, depending on their thickness
	<b>Tray 3/4</b>	Not supported

<b>Orientation</b>	<b>Tray 1</b>	Face down
	<b>Tray 2</b>	Face up
<b>Driver Media Type</b>	Postcard	
<b>Duplexing</b>	Not supported	

### Use postcards that are

- Approved for laser printing

### DO NOT use postcards that are

- Coated
- Designed for inkjet printers
- Precut or perforated
- Preprinted or multicolored



*If the postcard is warped, press on the warped area before putting it in the tray 1/2.*

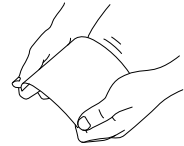

- Folded or wrinkled

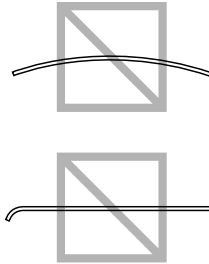

### Glossy Media

You can print continuously with glossy media. However, this could affect the media feed, depending on the media quality and printing environment. If problems occur, stop the continuous printing and print one sheet at a time.

Check your application documentation for more information on printing glossy media.

<b>Capacity</b>	<b>Tray 1/2</b>	Up to 20 sheets, depending on their thickness
	<b>Tray 3/4</b>	Not supported

<b>Orientation</b>	<b>Tray 1</b>	Face down
	<b>Tray 2</b>	Face up
<b>Driver Media Type</b>	Glossy 1 (100–128 g/m <sup>2</sup> ) Glossy 2 (129–158 g/m <sup>2</sup> )	
<b>Weight</b>	100 to 158 g/m <sup>2</sup>	
<b>Duplexing</b>	Not supported	

## Single Side Only

Print on the single side only.

You can print continuously with single side only paper. However, this could affect the media feed, depending on the media quality and printing environment. If problems occur, stop the continuous printing and print one sheet at a time.

Select this setting when paper that should not be used with double sided copying (for example, when one side has already been printed on) is loaded as plain paper with a weight of 60–90 g/m<sup>2</sup>.

<b>Capacity</b>	<b>Tray 1</b>	Up to 100 sheets, depending on the paper weight.
	<b>Tray 2</b>	Up to 250 sheets, depending on the paper weight.
	<b>Tray 3/4</b>	Up to 500 sheets, depending on the paper weight.
<b>Orientation</b>	<b>Tray 1</b>	Face down
	<b>Tray 2/3/4</b>	Face up
<b>Driver Media Type</b>	Single Side Only (60–90 g/m <sup>2</sup> )	
<b>Weight</b>	60–90 g/m <sup>2</sup>	
<b>Duplexing</b>	Not supported	

### Use single side only paper that is

- Suitable for plain paper laser printers, such as standard or recycled office paper
- Plain paper that has been printed on with same printer

### DO NOT use single side only paper that is

- Not approved for use as plain paper



## Special Paper

You can print continuously with special paper. However, this could affect the media feed, depending on the media quality and printing environment. If problems occur, stop the continuous printing and print one sheet at a time.

Select this setting when special paper, for example, color high-quality paper (color paper), is loaded as plain paper with a weight of 60–90 g/m<sup>2</sup>.

<b>Capacity</b>	<b>Tray 1</b>	Up to 100 sheets, depending on the paper weight.
	<b>Tray 2</b>	Up to 250 sheets, depending on the paper weight.
	<b>Tray 3/4</b>	Up to 500 sheets, depending on the paper weight.
<b>Orientation</b>	<b>Tray 1</b>	Face down
	<b>Tray 2/3/4</b>	Face up
<b>Driver Media Type</b>	Special Paper (60–90 g/m <sup>2</sup> )	
<b>Weight</b>	60–90 g/m <sup>2</sup>	
<b>Duplexing</b>	Refer to “Specifications” on page 4-2.	

### Use special paper that is

- Approved for laser printers

### DO NOT use special paper that is

- Not approved for use as plain paper

## Printable Area

The printable area on all media sizes is up to 4.2 mm (0.165") from the edges of the media.

Each media size has a specific imageable area, the maximum area on which the printer can print clearly and without distortion.

This area is subject to both hardware limits (the physical media size and the margins required by the printer) and software constraints (the amount of memory available for the full-page frame buffer). The guaranteed imageable (printable) area for all media sizes is the page size minus 4.2 mm (0.165") from all edges of the media.

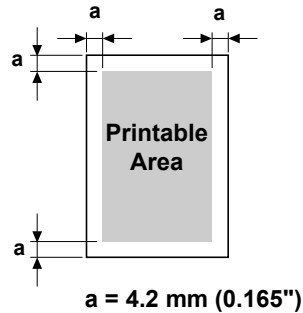

*When printing in color on legal-size media, the following limitations apply.*

- *The printable area is 347.2 (13.7") mm from the leading edge of the paper. (However, there is a non-printable area up to 4.2 mm (0.165") from the leading edge.)*
- *The bottom margin is 14.2 mm (0.56").*

## Envelopes

Envelopes can only be printed on their front sides (side where the recipient's address is written). In addition, printing on the front side in the area overlapping the back flap cannot be guaranteed. The location of this area differs depending on the envelope type.

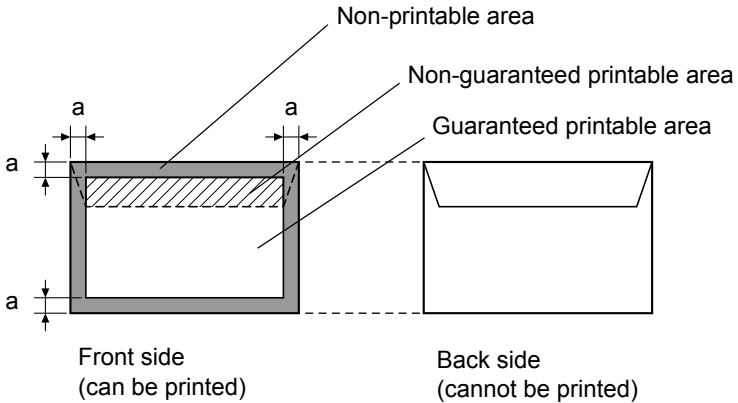

**a=4.2 mm (0.165")**



*The envelope print orientation is determined by your application.*

## Page Margins

Margins are set through your application. Some applications allow you to set custom page sizes and margins while others have only standard page sizes and margins from which to choose. If you choose a standard format, you may lose part of your image (due to imageable area constraints). If you can custom-size your page in your application, use those sizes given for the imageable area for optimum results.

# Loading Media

## How do I load media?

### Note

---

**Do not mix media of different types and sizes, as this will cause media misfeeds or machine trouble.**

---

### Note

---

**Paper edges are sharp and may cause injuries.**

---

When refilling media, first remove any media remaining in the tray. Stack it with the new media, even the edges, then reload it.

## Tray 1 (Manual Feed Tray)

For details on the types and sizes of media that can be printed from Tray 1, refer to "Specifications" on page 4-2.

### Loading Plain Paper, Single Side Only and Special Paper

- 1 Open Tray 1.

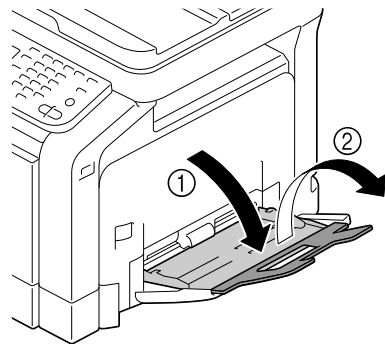

- 2** Slide the media guides to provide more space between them.

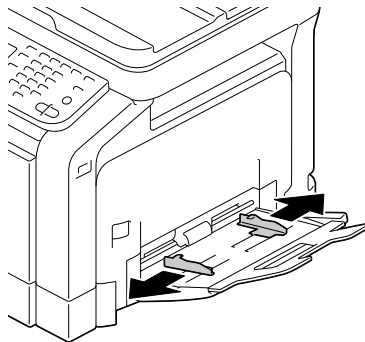

- 3** Press down on the center of the paper-lifting plate until the left and right locking tabs (white) lock into place.

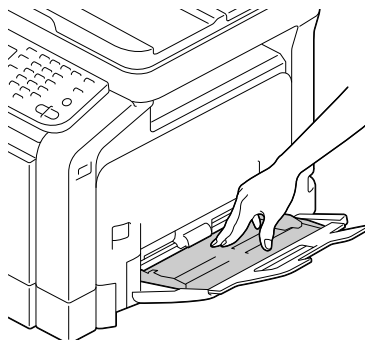

- 4** Load the paper face down in the tray.

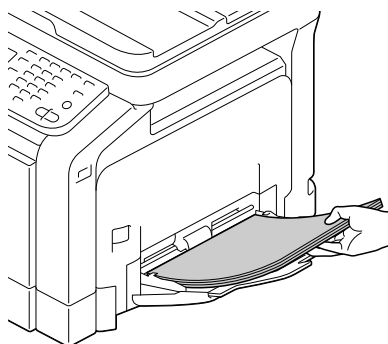



*Do not load so much paper that the top of the stack is higher than the maximum limit guide. Up to 100 sheets (80 g/m<sup>2</sup>) of plain paper can be loaded into the tray at one time.*

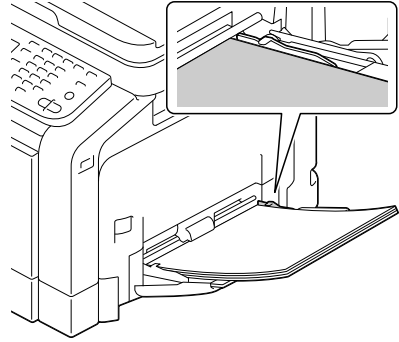

- 5** Slide the media guides against the edges of the paper.

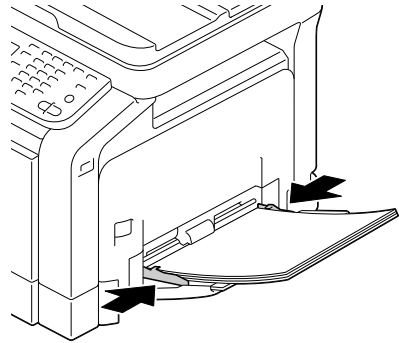

- 6** Select [Copy]/[Paper]/[Tray 1]/[Change Tray Set]/[Paper Size] and [Paper Type] in the configuration menu, and then select the setting for the size and type of paper that are loaded. See also “[Paper]” on page 7-5.

### **Other Media**

When loading media other than plain paper, set the media mode (Envelope, Label, Letterhead, Thick 1, Thick 2, Glossy 1, Glossy 2, or Postcards) in the driver for optimum print quality.

## Loading Envelopes

- 1 Open Tray 1.

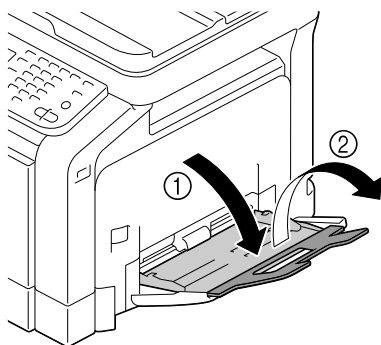

- 2 Slide the media guides to provide more space between them.

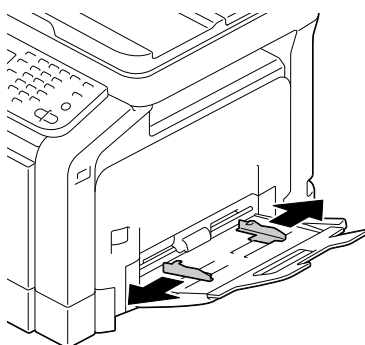

- 3 Press down on the center of the paper-lifting plate until the left and right locking tabs (white) lock into place.

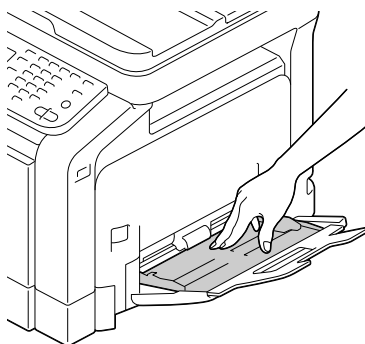

- 4** Load the envelopes flap side up in the tray.



*Before loading envelopes, press them down to make sure that all air is removed, and make sure that the folds of the flaps are firmly pressed; otherwise the envelopes may become wrinkled or a media misfeed may occur.*

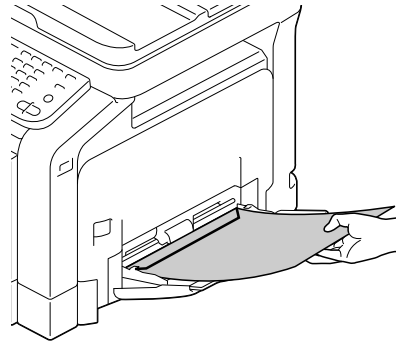

*Up to 10 envelopes can be loaded into the tray at one time.*



*For envelopes with the flap along the long edge (Envelope C6, Envelope Monarch, Envelope You #6, Envelope You #2, and Envelope DL), load the envelopes with the flap side up.*

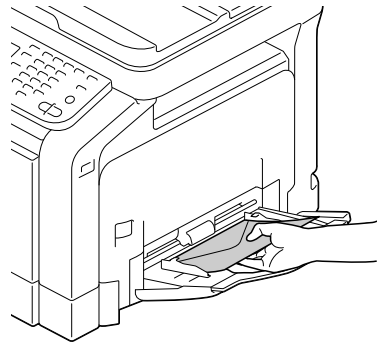

- 5** Slide the media guides against the edges of the envelopes.

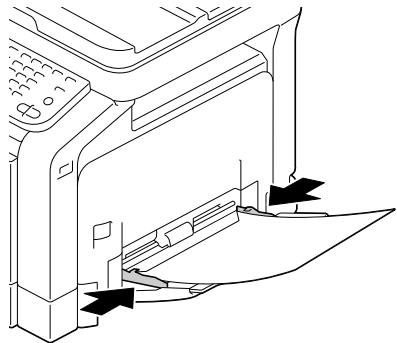



- 6 Select [Copy]/[Paper]/[Tray 1]/[Change Tray Set]/[Paper Size] and [Paper Type] in the configuration menu, and then select the setting for the size and type of paper that are loaded. See also.

## Loading Label Sheets/Letterhead/Postcards/Thick Stock and Glossy Media

- 1 Open Tray 1.

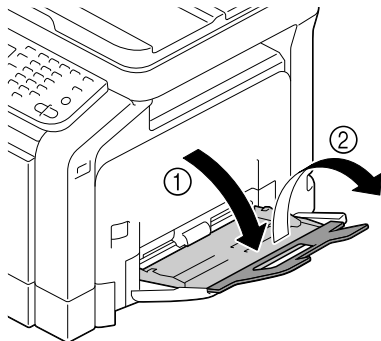

- 2 Slide the media guides to provide more space between them.

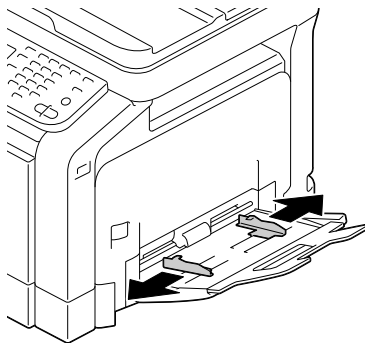

- 3** Press down on the center of the paper-lifting plate until the left and right locking tabs (white) lock into place.

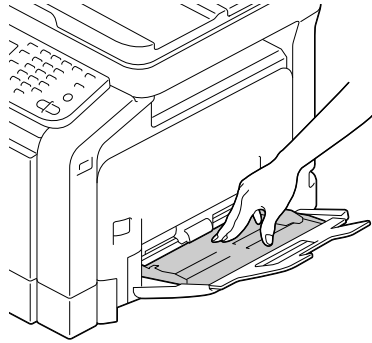

- 4** Load the media face down in the tray.



*Up to 20 sheets can be loaded into the tray at one time.*

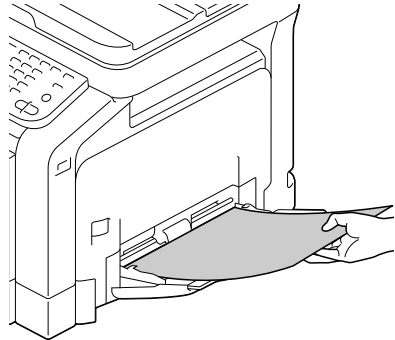

- 5** Slide the media guides against the edges of the media.

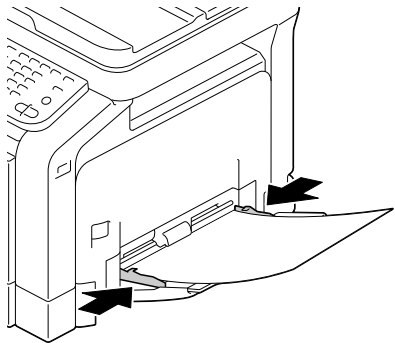

- 6** Select [Copy]/[Paper]/[Tray 1]/[Change Tray Set]/[Paper Size] and [Paper Type] in the configuration menu, and then select the setting for the size and type of paper that are loaded. See also "[Paper]" on page 7-5.

## Tray 2

### Loading Plain Paper, Single Side Only and Special Paper

- 1 Pull out Tray 2.

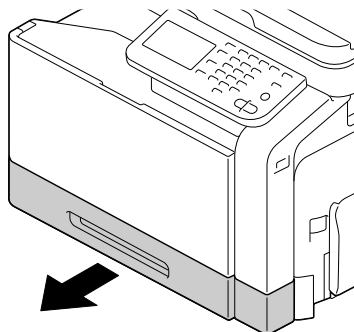

- 2 Press down the media pressure plate to lock it into place.

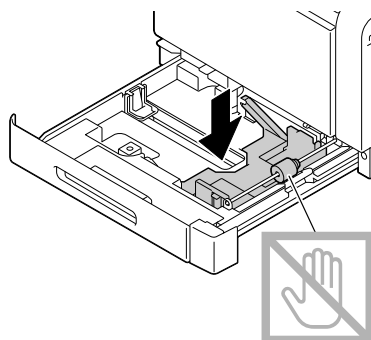

- 3 Slide the media guides to provide more space between them.

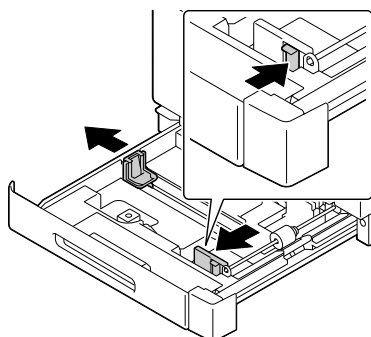

- 4 Turn the paper selection dial to select the size of paper to be loaded.

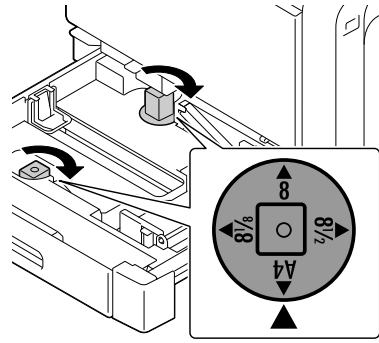

- 5 Load the paper face up in the tray.

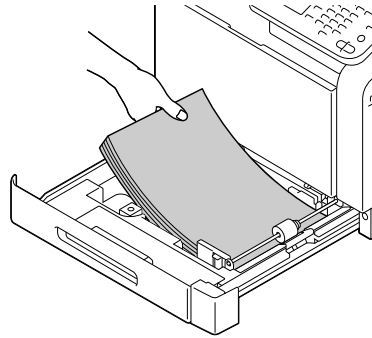

*Do not load above the ▼ mark. Up to 250 sheets (80 g/m<sup>2</sup>) of plain paper can be loaded into the tray at one time.*

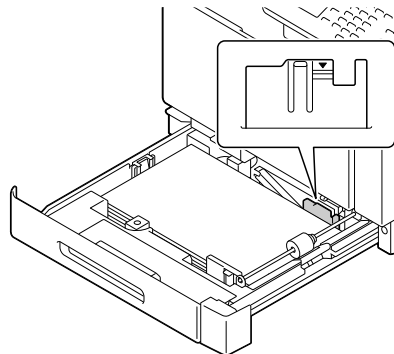

- 6** Slide the media guides against the edges of the paper.

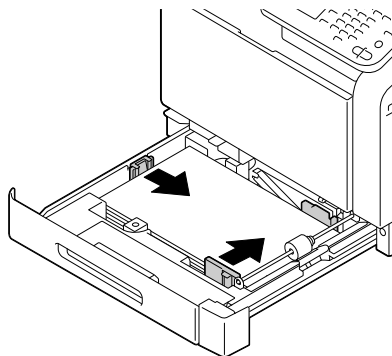

- 7** Close Tray 2.

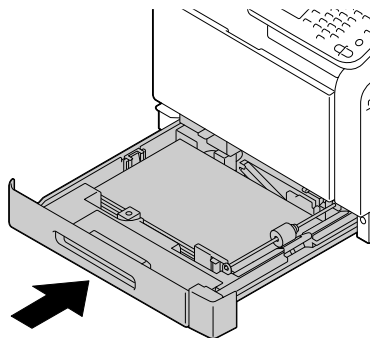

- 8** Select [Copy]/[Paper]/[Tray 2]/[Change Tray Set]/[Paper Size] and [Paper Type] in the configuration menu, and then select the setting for the size and type of paper that are loaded. See also “[Paper]” on page 7-5.

## Loading Label Sheets/Letterhead/Postcards/Thick Stock and Glossy Media

- 1 Pull out Tray 2.

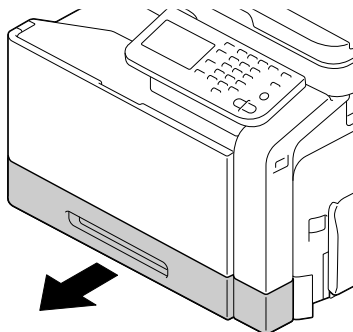

- 2 Press down the media pressure plate to lock it into place.

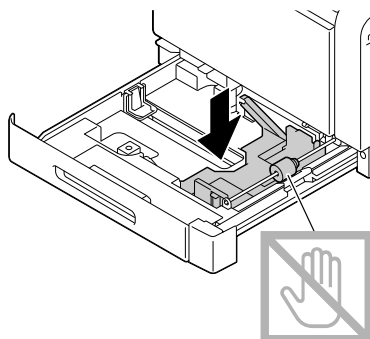

- 3 Slide the media guides to provide more space between them.

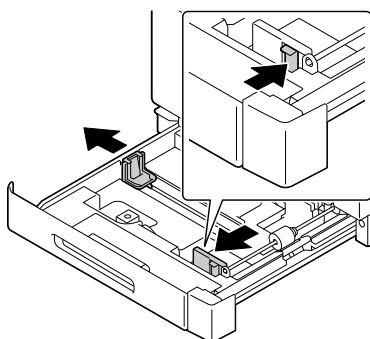

- 4 Turn the paper selection dial to select the size of paper to be loaded.

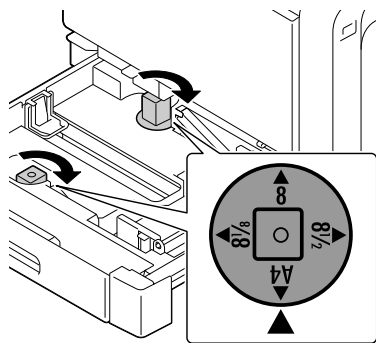

- 5 Load the paper face up in the tray.

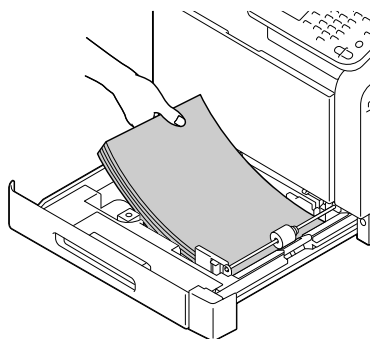

*Up to 20 sheets can be loaded into the tray at one time.*

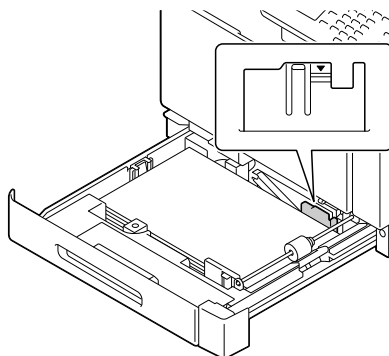

- 6 Slide the media guides against the edges of the paper.

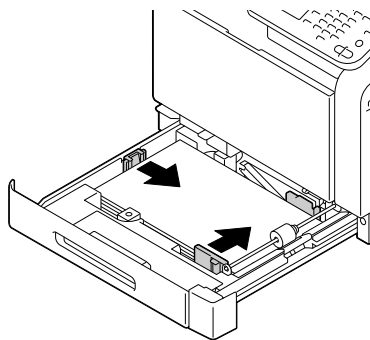

- 7 Close Tray 2.

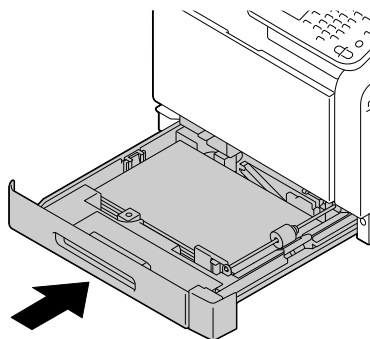

- 8 Select [Copy]/[Paper]/[Tray 2]/[Change Tray Set]/[Paper Size] and [Paper Type] in the configuration menu, and then select the setting for the size and type of paper that are loaded. See also “[Paper]” on page 7-5.



## Tray 3/4 (Optional Lower Feeder Unit)

### Loading Plain Paper, Single Side Only and Special Paper

- 1 Pull out Tray 3 or Tray 4.

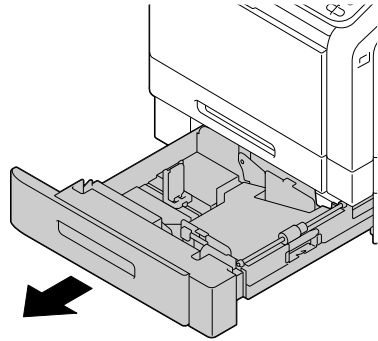

- 2 Press down the media pressure plate to lock it into place.

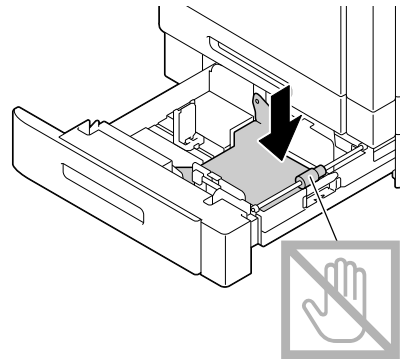

- 3 Slide the media guides to provide more space between them.

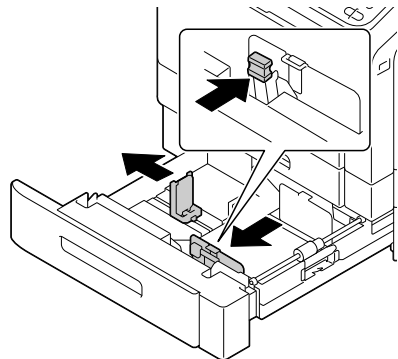

- 4** Load the paper face up in the tray.

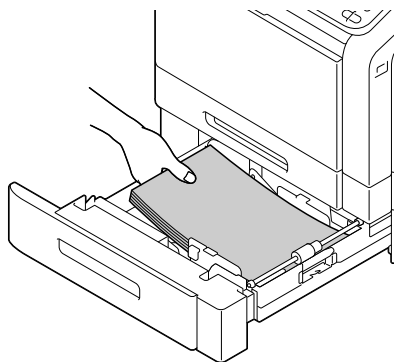

*Do not load above the ▼ mark. Up to 500 sheets (80 g/m<sup>2</sup>) of plain paper can be loaded into the tray at one time.*

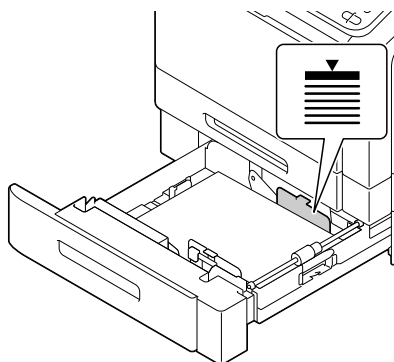

- 5** Slide the media guides against the edges of the paper.

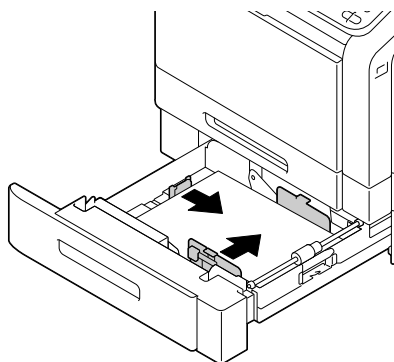

**6** Close Tray 3 or Tray 4.

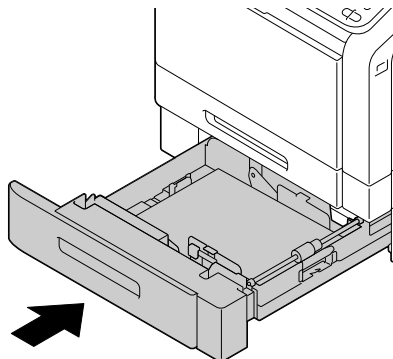

**7** Select [Copy]/[Paper]/[Tray 3]/[Change Tray Set]/[Paper Size] and [Paper Type] in the configuration menu, and then select the setting for the size and type of paper that are loaded. See also “[Paper]” on page 7-5.

# About Duplex Printing

Duplex (double-sided) printing can be done with this printer, which has the duplex unit built in as a standard. If the paper has low opacity (high translucency), then the printed data from one side of the page will show through to the other side. Check your application for margin information. For best results, print a small quantity to make sure the opacity is acceptable.

## Note

---

**Only plain paper, special paper and thick stock, 60–210 g/m<sup>2</sup> can be autoduplexed. See “Types” on page 4-4.**

**Duplexing envelopes, labels, letterheads, postcards, glossy media or single side only papers is not supported.**

---

## How do I autoduplex?

Check your application to determine how to set your margins for duplex (double-sided) printing.

The following Binding Position settings are available.

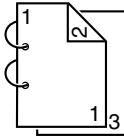
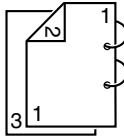
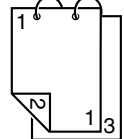
	If [Long Edge (Left)] is selected, the pages will be laid out to flip at the left.
	If [Long Edge (Right)] is selected, the pages will be laid out to flip at the right.
	If [Short Edge (Top)] is selected, the pages will be laid out to flip at the top.

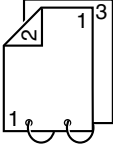
	<p>If [Long Edge (Bottom)] is selected, the pages will be laid out to flip at the bottom.</p>
---	---

In addition, if [Booklet] is selected, autoduplex printing is performed.

The following Order settings are available when [Booklet] is selected.

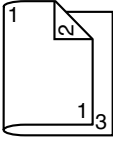
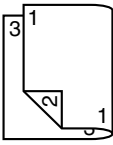
	<p>If [Left Binding] is selected, the pages can be folded as a left-bound booklet.</p>
	<p>If [Right Binding] is selected, the pages can be folded as a right-bound booklet.</p>

- 1 Load paper into the tray.
- 2 From the printer driver, specify duplex (double-sided) printing (Layout tab in Windows).
- 3 Click [OK].



*With autoduplexing, the back side is printed first, and then the front side is printed.*

# Output Tray

All media is fed out facing down into the output tray of the machine. This tray has a capacity of approximately 250 sheets (A4/Letter) of 80 g/m<sup>2</sup> paper.



*If the media is stacked too high in the output tray, your machine may experience media misfeeds, excessive media curl, or static buildup.*

# Media Storage

- Keep media on a flat, level surface in its original wrapper until it is time to load it.

*Media that has been stored for a long time out of its packaging may dry up too much and cause misfeeding.*

- If media has been removed from its wrapper, place it in its original packaging and store in a cool, dark place on a level surface.
- Avoid moisture, excessive humidity, direct sunlight, excessive heat, and dust

*Store paper in a location with a temperature between 0 °C and 30 °C and humidity between 30% and 85%.*

- Avoid leaning against other objects or placing it in an upright position.

Before using stored media, do a trial print and check print quality.

# Original Media

## Specifications

### Documents that can be placed on the original glass

The following types of documents can be placed on the original glass.

Document type	Sheets, books, three-dimensional object
Document size	Maximum size : Legal Copy and Scan : 30–216 × 30–356 mm Fax : 140–216 × 148–356 mm
Weight	Maximum weight : 3 kg

Observe the following precautions when placing a document on the original glass.

- Do not place objects weighing more than 3 kg on the original glass; otherwise the glass may be damaged.
- Do not press down extremely hard on a book spread on the original glass; otherwise the original glass may be damaged.

### Documents that can be loaded into the ADF

The following types of documents can be loaded into the ADF.

Document media type / Weight	Plain paper / 50 to 128 g/m <sup>2</sup>
Document size	Maximum size : Legal Mixed document sizes : Legal, Letter Copy and Scan : 140–216 × 148–356 mm (Single-sided/Double-sided) Fax : 140–216 × 148–1000 mm (Single-sided) 140–216 × 148–356 mm (Double-sided)
Media capacity	50 sheets (media weight: 80 g/m <sup>2</sup> )



Do not load the following types of documents into the ADF.

- Documents containing pages of different sizes
- Wrinkled, folded, curled, or torn documents
- Highly translucent or transparent documents, such as overhead transparencies or diazo photosensitive paper
- Coated documents such as carbon-backed paper
- Documents printed on paper thicker than 128 g/m<sup>2</sup>
- Documents with pages bound together with paper clips or staples
- Documents that are bound in a book or booklet
- Documents with pages bound together with glue
- Documents with pages that have had cutouts removed or are cutouts
- Label sheets
- Offset printing masters
- Documents with binder holes

# Loading a Document

## Placing a document on the original glass

1 Lift to open the ADF cover.

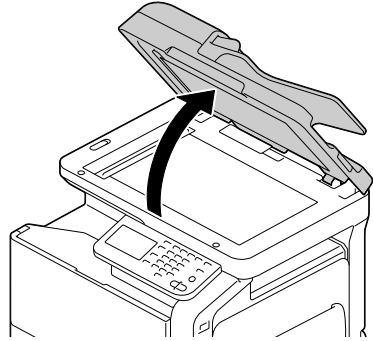

2 Position the document on the original glass.

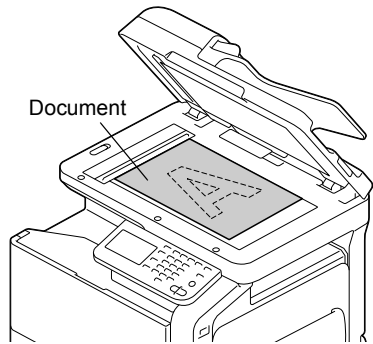

*Align the document with the arrow on the left side toward the rear of the machine.*

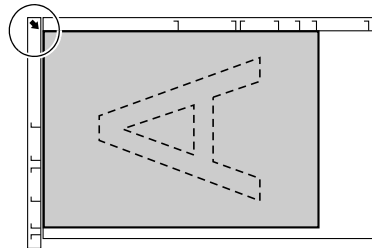

- 3** Gently close the ADF cover.

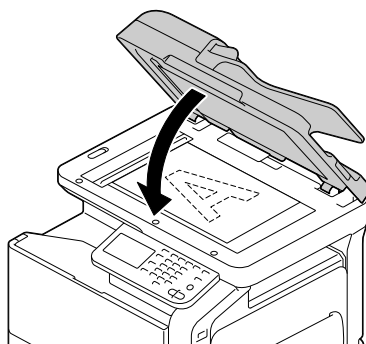

## Loading a document into the ADF

- 1** Put the document into the ADF document feed tray face up.



*Before loading a document into the ADF, check that no document pages remain on the original glass.*



*Load the document pages so that the top of the document is toward the back or the right side of the machine.*

- 2** Adjust the document guides to the document size.

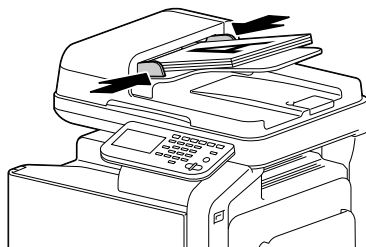
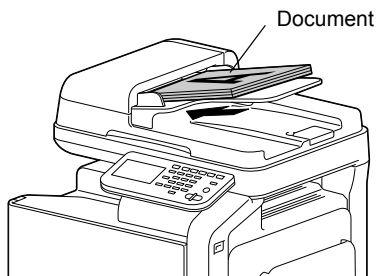

*For details on copying the loaded document, refer to “Performing Copy mode operations” on page 7-1. For details on scanning, refer to “Scanning From a Computer Application” on page 9-1.*



*Using the Printer  
Driver* **5**



# Selecting Driver Options/Defaults (for Windows)

Before you start working with your printer, you are advised to verify/change the default driver settings. Also, in case you have options installed, you should “declare” the options in the driver.

## Windows Server 2008 R2/7/Vista/Server 2008/XP/Server 2003/2000

- 1** Choose the driver's properties as follows:
  - (Windows 7/Server 2008 R2)  
From the [Start] menu, choose [Devices and Printers] to display the [Devices and Printers] directory. Right-click the Color MF30-1 PCL6, Color MF30-1 PS or Color MF30-1 XPS printer icon, and then click [Printer Properties].
  - (Windows Vista/Server 2008)  
From the [Start] menu, click [Control Panel], then [Hardware and Sound], and then click [Printers] to open the Printers directory. Right-click the Color MF30-1 PCL6, Color MF30-1 PS or Color MF30-1 XPS printer icon, and then click [Properties].
  - (Windows XP/Server 2003)  
From the [Start] menu, choose [Printers and Faxes] to display the [Printers and Faxes] directory. Right-click the Color MF30-1 PCL6 or Color MF30-1 PS printer icon and choose [Properties].
  - (Windows 2000)  
From the [Start] menu, choose [Settings] and then [Printers] to display the [Printers] directory. Right-click the Color MF30-1 PCL6 or Color MF30-1 PS printer icon and choose [Properties].
- 2** If you have installed options, proceed with the next step. Otherwise, skip to step 9.
- 3** Select the [Configure] tab.
- 4** Check that the installed options are correctly listed. If not, proceed with the next step. Otherwise, continue with step 8.
- 5** Click the [Acquire Device Information] to automatically configure installed options.



*The [Acquire Device Information] is available only if bi-directional communication is available with the printer; otherwise it is grayed out.*

*If Windows Server 2008 R2/7/Vista/Server 2008 is being used, [Acquire Device Information] can also be clicked when the machine is connected via USB.*

- 6 From the [Device Option] list, select an option, one at a time, and then select [Installed] or [None] from the [Setting] menu.
- 7 Click [Apply].



*Depending on the version of the operating system, [Apply] may not appear. If this is the case, continue with the next step.*

- 8 Select the [General] tab.
- 9 Click [Printing Preferences].  
Printing Preference dialog box appears.
- 10 Select the default settings for your printer, such as the default media format you use, in the appropriate tabs.
- 11 Click [Apply].
- 12 Click [OK] to exit from the Print preference dialog box.
- 13 Click [OK] to exit from the Properties dialog box.

# Uninstalling the Printer Driver (for Windows)

This section describes how to uninstall the printer driver if necessary.

## **Windows Server 2008 R2/7/Vista/Server 2008/XP/Server 2003/2000**

- 1** Close all applications.
- 2** Choose the Uninstall Program as follows:
  - (Windows Server 2008 R2/7/Vista/Server 2008/XP/Server 2003)  
From the [Start] menu, choose [All programs], [Color MF30-1, and then [Uninstall Printer Driver].
  - (Windows 2000)  
From the [Start] menu, choose [Programs], [Color MF30-1], and then [Uninstall Printer Driver].
- 3** When the Uninstall dialog box appears, select the name of the driver to be deleted, and then click the [Uninstall] button.
- 4** Click [Uninstall].
- 5** Click [OK], and restart your computer.
- 6** The printer driver will be uninstalled from your computer.



# Displaying Printer Driver Settings (for Windows)

## Windows 7/Server 2008 R2

- 1 From the [Start] menu, choose [Devices and Printers] to display the [Devices and Printers] directory.
- 2 Right-click the Color MF30-1 PCL6, Color MF30-1 PS or Color MF30-1 XPS printer icon, and then click [Printing Preferences].

## Windows Vista/Server 2008

- 1 From the [Start] menu, click [Control Panel], then [Hardware and Sound], and then click [Printers] to open the Printers directory.
- 2 Right-click the Color MF30-1 PCL6, Color MF30-1 PS or Color MF30-1 XPS printer icon, and then click [Printing Preferences].

## Windows XP/Server 2003

- 1 From the [Start] menu, choose [Printers and Faxes] to display the [Printers and Faxes] directory.
- 2 Right-click the Color MF30-1 PCL6 or Color MF30-1 PS printer icon and choose [Printing Preferences].

## Windows 2000

- 1 From the [Start] menu, point to [Settings], and then click [Printers] to display the [Printers] directory.
- 2 Right-click the Color MF30-1 PCL6 or Color MF30-1 PS printer icon and choose [Printing Preferences].

# Using the Postscript, PCL and XPS Printer Driver

## Common Buttons

The buttons described below appear on each tab.

### **[OK]**

Click to exit the Properties dialog box, saving any changes made.

### **[Cancel]**

Click to exit the Properties dialog box without saving any changes made.

### **[Apply]**

Click to save all changes without exiting the Properties dialog box.

### **[Help]**

Click to view the help.

### **[Favorite Setting]**

This allows the current settings to be saved. To save the current settings, specify the desired settings, and then click [Add]. Specify the settings described below, and then click [OK].

- [Name]: Type in the name of the settings to be saved.
- [Icon]: Select an icon from the icon list to easily identify the settings. The selected icon appears in the drop-down list.
- [Sharing]: Specify whether or not the settings to be saved can be used by other users logged onto the computer.
- [Comment]: Add a simple comment to the settings to be saved.

Afterward, the saved settings can be selected from the drop-down list. To change the registered setting, click [Edit].

In addition, predefined settings can be selected.

The predefined settings are those for [2 in 1], [Photo] and [Gray Scale].

Select [Default Setting] from the drop-down list to reset the functions in all tabs to their default values.

## [Printer View]

Click the button to display an image of the printer in the figure area.

When this button is clicked, it changes to the [Paper View] button (when a tab other than the [Quality] tab is selected) or the [Quality View] button (when the [Quality] tab is selected).



*This button does not appear on the [Advanced] tab.*

## [Paper View]

Click the button to display a sample of the page layout in the figure area.

When this button is clicked, it changes to the [Printer View] button.



*This button does not appear on the [Quality] tab.*

## [Quality View]

Click the button to display a sample of the settings selected in the [Quality] tab.

When this button is clicked, it changes to the [Printer View] button.



*This button appears only when the [Quality] tab is selected.*

## [Printer Information]

Click this button to start up Web Connection.



*This button is available only if a network connection has been established.*

## [Default]

Click the button to reset the settings to their defaults.



*This button does not appear on the [Advanced] tab.*



*When this button is clicked, the settings in the displayed dialog box are reset to their defaults. The settings on other tabs are not changed.*

## [Advanced] Tab (PostScript Printer Driver Only)

The [Advanced] Tab allows you to

- Select whether to enable or disable the settings for advanced printing functions (such as booklet printing)

- Specify the PostScript output method
- Specify whether or not the error messages of a print job are printed
- Print a mirror image
- Specify whether or not the application can directly output PostScript data

## [My Tab]

[My Tab] allows you to

- Display the most frequently used functions (from each tab) whose settings are often changed
- Add or remove displayed functions by clicking [Edit My Tab]. In addition, functions can be added to [My Tab] by right-clicking them on their original tabs.

## [Basic] Tab

The [Basic] Tab allows you to

- Specify the orientation of the media
- Specify the size of the original document
- Select the output media size
- Zoom (expand/reduce) documents
- Specify the paper tray
- Specify the type of media
- Specify the number of copies
- Turn on/off job collation
- Save a print job on the printer and print it later (Job Retention)
- Save a confidential job on the printer and protect it with a password
- Print a single copy for proofing
- Specify user authentication and account track settings
- Print on the back side of paper that has already been printed on



*Use paper that has been printed on with this printer.  
In addition, the page printed with this setting is not guaranteed.*



*Do not use the following types of paper.*

- Paper that has been printed on with an inkjet printer
- Paper that has been printed on with a monochrome/color laser printer/copier
- Paper that has been printed on with any other printer or fax machine



To display a list of jobs saved with a [Job Retention] setting, press [USB/HDD] in the home screen, and then press [Proof Print]. Print the document by selecting the job in the list.

The password must be entered if one has been specified for the job.

## [Layout] Tab

The [Layout] Tab allows you to

- Print several pages of a document on the same page (N in 1 printing)
- Print a single copy for enlargement and print several pages (PCL printer driver only)
- Rotate the print image 180 degrees
- Specify whether or not blank pages are printed (PCL and XPS printer driver only)
- Specify duplex (double-sided) printing
- Specify booklet printing
- Specify binding position
- Adjust the binding margin
- Specify the position on the paper where the document is to be printed (PCL printer driver only)

## [Cover Mode] Tab

The [Cover Mode] Tab allows you to

- Print front and back cover pages and separator pages
- Specify the tray that contains the paper for the front and back cover pages and separator pages

## [Stamp/Composition] Tab



Be sure to use overlays with print jobs with a paper size and orientation that matches the overlay form.

In addition, if settings have been specified for [N in 1] or [Booklet] in the printer driver, the overlay form cannot be adjusted to match the specified settings.

The settings in the Watermark function of the [Stamp/Composition] tab allows you to

- Select the watermark to be used
- Create, edit or delete watermarks
- Adjust the watermark position

- Print a frame around watermarks
- Print transparent (shaded) watermarks
- Print the watermark on only the first page
- Print the watermark repeatedly throughout the all pages

The [Copy Protect] function prevents unauthorized copying.

- The document is printed with the specified text or pattern in the background. The background pattern is normally inconspicuous, but becomes visible when the document is copied. (PCL printer driver only)

The settings in the Overlay function of the [Stamp/Composition] tab allows you to

- Select the form to use
- Add or delete overlay files
- Launch Download Manager to download a form (PostScript printer driver only)



*Download Manager Application should be installed earlier.*

- Create a form (PCL and XPS printer driver only)
- Specify that the document and form are printed overlapping (PCL and XPS printer driver only)
- Display the form information (PCL and XPS printer driver only)
- Print the form on [All Pages], [1st Page Only], [Even Page] and [Odd Page]
- Place the form in back of the document or in front on the printed document (PCL and XPS printer driver only)

## [Quality] Tab

The [Quality] Tab allows you to

- Switch between color and grayscale printing
- Control the darkness of an image (Brightness)
- Specify the printer color settings
- Perform color separation
- Select whether or not economy printing is used
- Set the edge strength to [Low], [Middle] or [High]
- Specify the amount of details in graphic patterns (PCL and XPS printer driver only)
- Specify the format of fonts that are to be downloaded (PCL and Postscript printer driver only)

- Print using the printer's fonts (PCL and Postscript printer driver only)
- Control the tones of an image (Contrast) (PCL printer driver only)
- Specify the image compression method (PCL printer driver only)
- Select whether or not Auto Trapping function is used (Postscript printer driver only)
- Specify the Black Over Print function (Postscript printer driver only)

## **[Other] Tab**

The [Other] Tab allows you to

- Select that Microsoft Excel sheets are not to be divided when printing (32bit printer driver only)
- Select that the white background of Microsoft PowerPoint data does not hide overlay files (32bit PCL and XPS printer driver only)
- Send a notification by E-mail when printing is finished
- Shows the version information for the printer driver
- Prevent loss when printing fine lines (PCL printer driver only)

## **Limitations on printer driver functions installed with Point and Print**

If Point and Print is performed with the following server and client combinations, there are limitations on some printer driver functions.

- Server and client combinations  
Server: Windows Server 2008 R2/Server 2008/Server 2003  
Client: Windows 7/Vista/XP/2000
- Functions with limitations applied  
Booklet, Skip Blank Pages, Front Cover, Back Cover, Separator Page, Create Overlay File, Print in Overlay, Watermark  
\*JOBNAME, USERNAME, and HOSTNAME output of PDL





*Proof Print,  
External memory  
and ID & Print  
functions*

# 6



# Proof Print

Print jobs saved on hard disk can be printed or deleted.



*If [Store Job], [Print and Hold], [Secured Job], [Secured Job(Encryption)] or [Proof then Print] was selected for [Job Retention] in the printer driver, the job file is saved on the hard disk.*

## Printing a job saved on the hard disk

- 1 In the home screen, press [USB/HDD].
- 2 Press [Proof Print].
- 3 Select a user.
- 4 Press [OK].
- 5 Select the job to be printed.
- 6 Press [Print].



*If the job was saved with the [Secured Job] or [Secured Job(Encryption)] setting, type in the password.*

- 7 Type in the number of copies to be printed, and then press [OK].

## Deleting a job saved on the hard disk

- 1 In the home screen, press [USB/HDD].
- 2 Press [Proof Print].
- 3 Select a user.
- 4 Press [OK].
- 5 Select the job to be deleted.
- 6 Press [Delete].



*If the job was saved with the [Secured Job] or [Secured Job(Encryption)] setting, type in the password.*

- 7 Press [Yes], and then press [OK].

# External Memory

PDF, XPS, JPEG and TIFF files saved on USB memory devices can be printed by plugging the USB memory device into the machine.

## Printing from a connected USB memory device

- 1 Plug the USB memory device into the USB HOST port.  appears at the bottom of the screen.

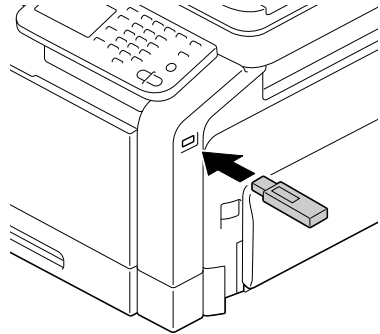

- 2 In the home screen, press [USB/HDD].
- 3 Press [External Memory].
- 4 Press [File List].
- 5 Select the file to be printed.  
If the file to be printed is in a folder, select the folder, and then press [Open]. To return to the folder containing the one that is currently displayed, press [Up].



*At each folder level, a maximum of 99 folders and files can be displayed.*



*The names of folders are displayed given priority over the names of files.*



*A maximum of eight folder levels can be displayed.*



*If JPEG and TIFF files are not displayed, select the file type with [File Type].*

- 6 Press [OK].
- 7 Specify the print settings.
- 8 Press [Print].



*Do not unplug the USB memory device from the USB HOST port during printing.*

## Selecting the type of files to be displayed

- 1 In the home screen, press [USB/HDD].
- 2 Press [External Memory].
- 3 Press [File Type].
- 4 Select the type of files to be displayed.
- 5 Press [OK].

## ID & Print

If a job is printed on this machine with user authentication through the printer driver using the registered user or public user privilege, it is saved as an ID & Print job on the hard disk of this machine.



*When using batch printing for an ID & Print job, the copying cannot be interrupted.*

### Printing simultaneously with log-in

- 1 Specify a name and password for [User Name] and [Password].
  - For [User Name], the name can be specified either by directly typing it in or selecting from a list.
- 2 Press [Begin Printing].
- 3 Press [Login].

The user is authenticated and printing starts.

### Specifying a job to print

- 1 Specify a name and password for [User Name] and [Password].
  - For [User Name], the name can be specified either by directly typing it in or selecting from a list.
- 2 Press [Access Basic Screen].
- 3 Press [Login].

This authenticates the user and returns to the home screen.
- 4 In the home screen, press [USB/HDD].
- 5 Press [ID & Print].
- 6 Select [Login User] or [Public User] as the user who sends a job.
- 7 Select the job to be printed.
- 8 Press [Print].

## Deleting a job

- 1 Specify a name and password for [User Name] and [Password].
  - For [User Name], the name can be specified either by directly typing it in or selecting from a list.
- 2 Press [Access Basic Screen].
- 3 Press [Login].  
This authenticates the user and returns to the home screen.
- 4 In the home screen, press [USB/HDD].
- 5 Press [ID & Print].
- 6 Select [Login User] or [Public User] as the user who sends a job.
- 7 Select the job to be deleted.
- 8 Press [Delete].
- 9 Press [Yes], and then press [OK].



*Performing  
Copy mode  
operations* **7**



# Basic copy operation

The general procedure for making copies is described below.

- 1 Place the document on the original glass or load it into the ADF.



*For details on positioning the document, refer to “Placing a document on the original glass” on page 4-36 and “Loading a document into the ADF” on page 4-37.*

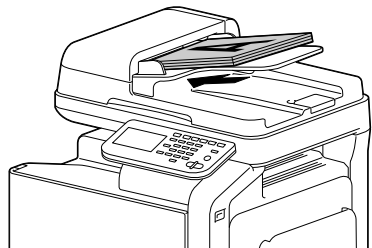
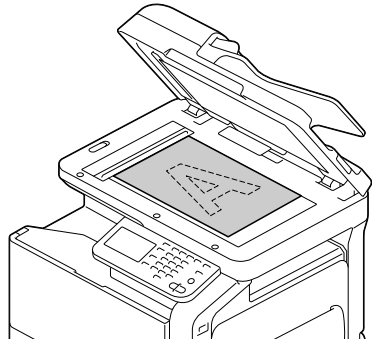

- 2 In the home screen, press [Copy].



*When the [Start (Color)] or [Start (B&W)] key is pressed in the home screen, the job can be copied with the defaults.*

- 3 Specify the desired copy settings.



*For details on specifying document size settings, refer to “[Original Size]” on page 7-4.*

*For details on specifying paper size settings, refer to “[Paper]” on page 7-5.*

*For details on specifying zoom ratio settings, refer to “[Zoom]” on page 7-6.*

*For details on specifying double-sided copy settings, refer to “[Duplex/Combine]” on page 7-7.*

*For details on specifying density settings, refer to “[Density]” on page 7-8.*

*For details on specifying document type settings, refer to “[Original*



Type]" on page 7-9.

For details on specifying color settings, refer to "[Color Mode]" on page 7-9.

For details on specifying Finishing settings, refer to "[Finishing]" on page 7-10.

For details on performing the Proof Copy operation, refer to "[Proof Copy]" on page 7-10.

For details on performing the Separate Scan operation, refer to "[Separate Scan]" on page 7-11.

For details on performing the ID Copy operation, refer to "[ID Copy]" on page 7-13.

For details on specifying a binding margin, refer to "[Paper Margin]" on page 7-14.

For details on adjusting the image quality, refer to "[Image Quality]" on page 7-15.

#### 4 Using the keypad, type in the desired number of copies.



If the number of copies was incorrectly entered, press the [C] key, and then type in the correct number of copies.

#### 5 To make a color copy, press the [Start (Color)] key.

To make a black-and-white copy, press the [Start (B&W)] key.



This machine cannot automatically detect the size of an original document that will be scanned. Before scanning the document, specify its size. If the size of the original document is not correctly specified, some parts of the image may be lost. For details on specifying the size of an original document, refer to "[Original Size]" on page 7-4.



When sorting or making double-sided or combined copies using the original glass, press [Finish] after all pages of the document have been scanned.



A screen showing the scanned document appears after the [Start (Color)] key or the [Start (B&W)] key is pressed. Check that the document was scanned as desired.

[Number Of Originals]: Number of scanned document pages

[Number Of Sets]: Number of scanned copies/specified number of copies

[Printed/TTL Pgs]: Number of copy pages printed/total number of pages to be printed (Does not appear during a Separate Scan operation.)



For details on interrupted printing (Interrupt Mode), refer to "Interrupting a copy job" on page 8-2.



*For details on copying using stored settings, refer to “Copy programs” on page 8-3.*



*A document containing pages of different sizes can be loaded into the ADF. For details on copying documents with pages of different sizes, refer to “[Original Size]” on page 7-4.*

## [Original Size]

The document size can be specified.

Item	Description
[Standard Size]	Select the size of the document.  Select [Letter/Legal] to copy a document containing different page sizes.
[Custom Size]	Specify the size of the document if it is a non-standard size.  Press [X] and [Y], and then type in the document size. [X] can be set between 30 mm and 356 mm (1.18 inches and 14.00 inches); [Y] can be set between 30 mm and 216 mm (1.18 inches and 8.50 inches).

### Documents of mixed page sizes

A document containing pages of different sizes (Letter and Legal) can be loaded into the ADF. Each document page will be copied onto paper of the same size as the original.



*Load all document pages so that they are aligned on the left side of the ADF.*

# [Paper]

The size and type of the paper to be printed on can be selected, and the size and type settings for the paper loaded into each paper tray can be changed.

The paper size can be selected automatically according to the document size or it can be specified manually.

Item	Description
[1]-[4]	Manually select the paper tray.  [3] and [4] are available if the optional lower feeder units have been installed.
[Auto]	The paper is selected automatically according to the size of the original document.
[Change Tray Set]	Specify the type and size of the paper loaded in the selected paper tray.
[Paper Size]	Specify the paper size.
[Standard Size]	Select the paper size.
[Custom Size]	Enter the size of the paper.
[Paper Type]	Select the paper type.



*For details on the paper types and sizes, refer to "Print Media" on page 4-2.*



*When paper is loaded in the bypass tray, the [Paper] screen appears while the bypass tray (tray 1) is selected automatically.*

## [Zoom]

The image size for the document can be enlarged or reduced.

Item	Description
[+]/[-]	<p>Specify the zoom ratio of the copy (25.0% to 400.0%).</p> <p>With documents loaded into the ADF, the zoom ratio can be set between 25% and 200%.</p>
[Set Zoom]	<p>The various preset zoom ratios and the zoom ratio for the [Minimal] setting can be changed.</p> <p>The zoom ratios can be set between 25.0% and 200.0%.</p>
Zoom settings	<p>Select a preset zoom ratio or a programmed zoom ratio.</p> <p>[Auto]: Select this setting for the most appropriate zoom ratio to be automatically selected based on the size of the loaded document and the specified paper size.</p> <p>[Full Size]: Select this setting to produce a copy that is the same size as the document (100.0%).</p> <p>[Manual]: Press [+] or [-] to enter a custom zoom ratio.</p> <p>[Minimal]: Select this setting to print a copy of the document image so that it is slightly smaller than the original document size.</p>

## [Duplex/Combine]

Whether the scanned document and the printed copy are printed on just one side or both sides can be specified. In addition, document images of multiple pages (2 or 4 pages) can be combined and printed on a single page.

Item	Description
[Duplex]	<p>Select whether simplex (single-sided) or duplex (double-sided) copies are to be printed.</p> <p>[1 &gt; 1]: Select this setting to produce single-sided copies from single-sided documents.</p> <p>[1&gt;2]: Select this setting to produce one double-sided copy from two single-sided documents.</p> <p>[2&gt;1]: Select this setting to produce two single-sided copies from one double-sided document.</p> <p>[2 &gt; 2]: Select this setting to produce double-sided copies from double-sided documents.</p>
[Combine]	<p>Select whether to make combined copies.</p> <p>[No]: Select this setting to not produce combined copies.</p> <p>[2 in 1]: Select this setting to copy two document pages onto one page.</p> <p>[4 in 1 Horizontal]: Select this setting to copy four document pages onto one page. The document images will be arranged horizontally.</p> <p>[4 in 1 Vertical]: Select this setting to copy four document pages onto one page. The document images will be arranged vertically.</p>

Item	Description
[Binding Position]	Specify the binding positions for the document and the copies.
[Orig. Binding Position]	Select [Left Bind], [Right Bind], [Top Bind] or [Auto] as the binding position for the document.  If the binding position for the document is set to [Auto], the binding position is set at the left or at the top.
[Output Binding Position]	Select [Left Bind], [Right Bind], [Top Bind] or [Auto] as the binding position for the copies.  If the binding position for the copy is set to [Auto], the binding position is set at the left or at the top.
[Original Direction]	Select [Top], [Bottom], [Left] or [Right] as the orientation of the document loaded into the ADF or placed on the original glass.

## [Density]

Specify the copy density.

Item	Description
[+]/[-]	Adjust the copy density to one of nine levels.
[Standard]	Select this setting to return the copy density to the standard setting.

## [Original Type]

Select the document quality (text or image documents).

Item	Description
[Text]	Select this setting when copying documents containing only text.
[Text/Photo]	Select this setting when copying documents containing both text and photos.  Black text, color text and shading are automatically recognized, and the most appropriate image processing is performed.  In addition, processing appropriate for printed photo documents will be applied to any photos.
[Photo]	Select this setting when copying documents containing printed photos.

## [Color Mode]

Specify the printing color used for copies.

Copies will be printed with the specified Color setting when the [Start (Color)] key is pressed.

Item	Description
[Auto]	Select this setting to detect whether the scanned document is in color or in black and white, then automatically print copies in either color or black and white.
[Full Color]	Select this setting to print the copy in full color, regardless of whether the scanned document is in color or in black and white.

## [Finishing]

Specify any settings for finishing outputted copies.

Item	Description
[Sort]	Select this setting when making multiple copies of documents containing multiple pages so that they will be automatically separated into sets of the full document.
[Group]	Select this setting when making multiple copies of documents containing multiple pages so that they will be automatically separated into sets of each page.
[Auto]	Select this option to automatically switch between [Sort] and [Group] depending on the number of printable sheets per copy.  [Group] is set when printing a single sheet in the 1-sided or 2-sided mode, and [Sort] is set when printing multiple sheets.

## [Proof Copy]

Before printing a large number of copies, a single finished proof copy can be printed in order to be checked. Select whether or not to print a proof copy.

Item	Description
[ON]	Select this setting to print a proof copy.
[OFF]	Select this setting to not print a proof copy.

### Proof Copy operation



*When printing a proof copy, specify multiple copies.*

- 1 In the home screen, press [Copy].
- 2 Place the document on the original glass or load it into the ADF.



*For details on positioning the document, refer to "Placing a document on the original glass" on page 4-36 and "Loading a document into the ADF" on page 4-37.*

- 3 Specify the copy settings.
- 4 Press [Proof Copy].



- 5 Press [ON].
- 6 Press [OK].
- 7 Press the [Start (Color)] key or the [Start (B&W)] key.  
A single proof copy is printed.
- 8 Check the proof copy.  
If the proof copy was printed as desired, continue with step 9.



*Using the keypad, the number of copies can be changed.*



*To print another proof copy, press [Proof Copy].*



*To change the settings, press [Cancel], and then perform steps 2 through 8.*

- 9 Press [Print].  
The remaining number of copies is printed.

## [Separate Scan]

The scan operation can be divided into several sessions, for example, when all pages of a document cannot be loaded into the ADF, and then the scanned pages can be treated as a single copy job. In addition, the scanning location can be switched between the original glass and the ADF during the scanning operation.

Item	Description
[ON]	Select this setting to perform a Separate Scan operation.
[OFF]	Select this setting to not perform a Separate Scan operation.

## Scanning the document in separate batches

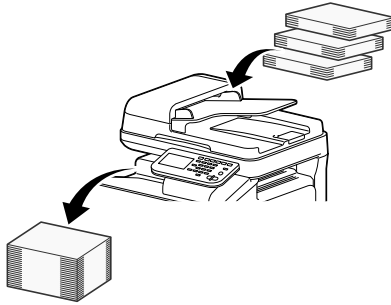

*Do not load more pages into the ADF than the maximum number of pages allowed, otherwise a document misfeed or damage to the document may occur.*



*When sorting or making double-sided or combined copies using the original glass, instead of using the Separate Scan operation, the document can be scanned as a multiple-page document.*

- 1 In the home screen, press [Copy].
- 2 Place the document on the original glass or load it into the ADF.



*For details on positioning the document, refer to "Placing a document on the original glass" on page 4-36 and "Loading a document into the ADF" on page 4-37.*

- 3 Specify the copy settings.
  - 4 Press [Separate Scan].
  - 5 Press [ON].
  - 6 Press [OK].
  - 7 Press the [Start (Color)] key or the [Start (B&W)] key.  
Scanning of the document begins.
-  *To change the scanning settings, press [Change Settings].*
- 8 Position the next document page or pages, and then press the [Start (Color)] key or the [Start (B&W)] key.  
Scanning of the document begins.
  - 9 Repeat step 7 until all document pages have been scanned.
  - 10 After all document pages have been scanned, press [Finish].

## [ID Copy]

The back and front of a card, such as an insurance card, driver's license or business card, can be scanned separately and printed together on a single page.

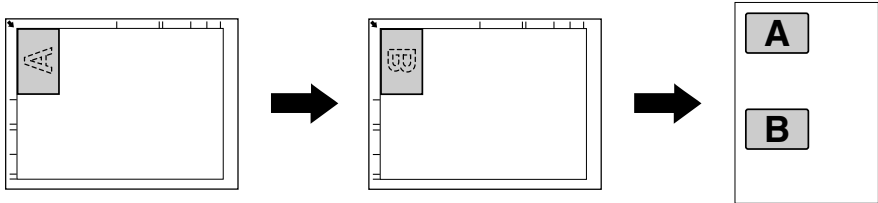

*With the ID Copy operation, the zoom ratio is set to 100%.*



*The paper sizes that are available for copying are Letter, Legal and A4.*



*The card can only be placed on the original glass. Position the card to be scanned aligned at the upper-left corner of the original glass. Since the image is printed 4 mm from the top and left side, reposition the card as necessary*

- 1 In the home screen, press [Copy].
- 2 Place the card, front side down, on the original glass.



*For details on positioning the document, refer to "Placing a document on the original glass" on page 4-36.*

- 3 Specify the copy settings.
- 4 Press [ID Copy].
- 5 Press the [Start (Color)] key or the [Start (B&W)] key.  
Scanning of the front side begins.
- 6 Position the card, back side down, at the same location on the original glass.



*To copy only the front side, press [Print].*

- 7 Press the [Start (Color)] key or the [Start (B&W)] key.  
Scanning of the back side begins.  
The copy is fed out.

# [Paper Margin]

Copies can be printed with a binding margin so they can easily be stored in filing binders.

Item	Description
[+]/[-]	Specify the width of the binding margin between 0.1 mm and 20.0 mm (0.001 inches and 0.787 inches).
[None]	Select this setting to leave no binding margin.



*If part of the image is lost due to the binding margin setting, reduce the zoom ratio before printing copies.*

# [Image Quality]

The quality can be adjusted for the document to be scanned.

Item	Description
[Background removal]	<p>Adjust the background density when copying documents with a colored background (such as newspapers or recycled paper) or thin documents where the back side is visible from the front side.</p> <p>Adjust the background density to one of nine levels. Select a setting in the + direction to darken the background, or select a setting in the - direction to lighten the background. Press [Standard] to return the density to the standard setting.</p>
[Contrast]	<p>The image can be adjusted to make it softer or sharper.</p> <p>Adjust the contrast to one of nine levels. Select a setting in the + direction to make the image sharper, or select a setting in the - direction to make the image softer. Press [Std.] to return the contrast to the standard setting.</p>
[Sharpness]	<p>The sharpness of text and image outlines can be adjusted.</p> <p>Adjust the sharpness to one of seven levels. Select a setting in the + direction to increase the sharpness, or select a setting in the - direction to decrease the sharpness. Press [Std.] to return the sharpness to the standard setting.</p>



*Additional copy  
operations* **8**



# Interrupting a copy job

The current jobs can be temporarily interrupted so a document can be copied with different copy settings.

This is convenient for quickly making a copy.



*The [Interrupt] key cannot be pressed while a document is being scanned.*



*When the [Interrupt] key is pressed, the copy settings return to their defaults.*

- 1 In the home screen, press [Copy].
- 2 Place the document on the original glass or load it into the ADF.



*For details on positioning the document, refer to "Placing a document on the original glass" on page 4-36 and "Loading a document into the ADF" on page 4-37.*

- 3 Press the [Interrupt] key.  
The indicator on the [Interrupt] key lights up in green, and printing of the current job stops.
- 4 Specify the copy settings.
- 5 To make a color copy, press the [Start (Color)] key.  
To make a black-and-white copy, press the [Start (B&W)] key.
- 6 After the interrupting job has finished printing, press the [Interrupt] key.  
The indicator on the [Interrupt] key goes off, and Interrupt mode is canceled.  
Printing of the job that was interrupted continues.



# Copy programs

Frequently used copy settings can be stored together as a program to easily be recalled later.

## Storing a copy program



*A maximum of 15 copy programs can be stored.*

- 1 In the home screen, press [Copy].
- 2 Specify the copy settings.
- 3 Press the [Mode Memory] key.  
The copy programs screen appear.
- 4 Press [Register].
- 5 Press [Name].
- 6 Type in the name of the copy program, and then press [OK].



*For details on entering text, refer to "Entering text" on page A-8.*

- 7 Press [OK].
- 8 Press [Cancel].  
The initial Copy mode screen appears again.

## Deleting a copy program

- 1 In the home screen, press [Copy].
- 2 Press the [Mode Memory] key.  
The copy programs screen appear.
- 3 Select the copy program to be deleted.
- 4 Press [Delete].
- 5 Press [Yes].
- 6 Press [OK].
- 7 Press [Cancel].  
The initial Copy mode screen appears again.

## Copying using stored settings (copy programs)

- 1 In the home screen, press [Copy].
- 2 Place the document on the original glass or load it into the ADF.  
 *For details on positioning the document, refer to "Placing a document on the original glass" on page 4-36 and "Loading a document into the ADF" on page 4-37.*
- 3 Press the [Mode Memory] key.  
The copy programs screen appear.
- 4 Select the copy program to be recalled.
- 5 Press [Detail].  
The settings screen appears.
- 6 Check the copy settings stored with the selected copy program.
- 7 Press [Close].
- 8 Press [OK].  
The initial Copy mode screen appears again.
- 9 Press the [Start (Color)] key or the [Start (B&W)] key.

*Scanning From a  
Computer  
Application* **9**

---

# Basic Scanning Operation

Documents can be scanned from a computer connected to this machine via a network. Scanning settings can be specified and the scanning operation can be performed from TWAIN- or WIA-compatible applications. From the scanner driver, a preview can be displayed and various adjustments, such as the size of the scan area, can be specified.



*For details on the installation of the scanner driver or network TWAIN settings, refer to the Installation Guide on the Documentation CD/DVD.*

- 1 Position the document to be scanned.



*For details on positioning the document, refer to “Placing a document on the original glass” on page 4-36 and “Loading a document into the ADF” on page 4-37.*

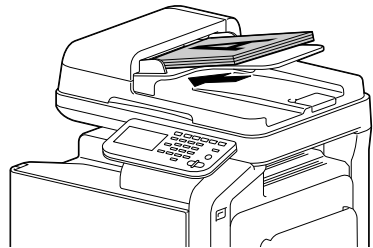
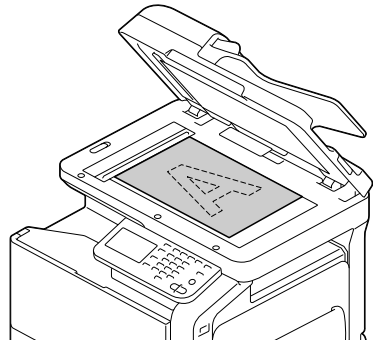

- 2 Start the application to be used for scanning.
- 3 Start the scanner driver according to the application settings.
- 4 Specify the necessary scanner driver settings.
- 5 Click the [Scan] button in the scanner driver.

# Windows TWAIN Driver Settings

## Mode settings

- [Mode Settings]

Select [Basic Mode] for specifying basic settings, or select [Advanced Mode] for specifying detailed settings.

The settings that can be specified differ for each mode.

## When [Basic Mode] is selected

The following parameters can be set when [Basic Mode] is selected.

- [Help] icon

Click to display Help information.

- [About] icon

Click to display the software version information.

- [Scan Objective]

Specify the document type.

- [Scan Type]

Specify the scan type.

- [Resolution]

Specify the resolution.

- [Auto Color Adjustment]

Specify the auto color adjustment settings.

- [Auto Deskew]

Specify settings for correcting the skew of the image.

- [Paper source]

Specify the paper source.

When scanning documents from the ADF, select whether to scan only the front side or both sides of the document.

- [Original Size]

Specify the original size.

- [Rotation]

Select the orientation of the image to be scanned.



*If the [Rotate back side] check box is selected, the back side of the image is rotated 180° and scanned. (Applies only if [ADF (2-sided)] is selected.)*

- [Image size]

Shows the data size of the scan image.

- [Close]

Click to close the TWAIN driver window.

- [Prescan]

Click to begin scanning a preview image.

- [Scan]

Click to begin scanning.

- [Clear] icon

Click to erase the preview image.

## When [Advanced Mode] is selected

The following parameters can be set when [Advanced Mode] is selected.

- [Load]

Specify a saved settings file (dat file) for scanning.

- [Save]

Save the current settings as a settings file (dat file).

- [Default]

Return all settings to their defaults.

- [Help icon]

Click to display the Help.

- [About icon]

Click to display the software version information.

- [Paper source]

Specify the paper source.

With scanning documents from the ADF, select whether to scan only the front side or both sides of the document.

- [Original Size]

Specify the original size.

- [Scan Type]

Specify the scan type.

■ [Resolution]

Specify the resolution.

■ [Scale]

Specify the enlargement or reduction ratio for the selected area.



*If the resolution is set at 1200 × 1200dpi or higher, a setting larger than 100% cannot be specified.*

■ Scanning Mode

Select [Auto] or [Manual]. When [Manual] is selected, a tab appears so that detailed settings can be specified, for example, for [Brightness/Contrast], [Filter], [Curves], [Levels], [Color Balance], and [Hue/Saturation].



*The parameters that can be set differ depending on the scanning mode that is selected.*



*The detailed settings that appear differ depending on the setting selected for [Scan Type].*



*If [Auto] is selected as the scanning mode, scanning from the original glass is performed after a prescan is performed so that a preview image can be checked.*

■ [Image size]

Shows the data size of the scan image.

■ [Rotation]

Select the orientation of the image to be scanned.



*If the [Rotate back side] check box is selected, the back side of the image is rotated 180° and scanned. (Applies only if [ADF (2-sided)] is selected)*

■ [Auto Deskew]

Specify settings for correcting the skew of the image.

■ [Close]

Click to close the TWAIN driver window.

■ [Prescan]

Click to begin scanning a preview image.

■ [Scan]

Click to begin scanning.

■ [AutoCrop] icon

Click to automatically detect the scanning position based on the preview image.

- [Zoom Prescan] icon

Click to rescan the area selected in the preview window and enlarge it to fit the window.

- [Mirror] icon

Click to display a mirror image of the preview image.

- [Tone Reversal] icon

Click to reverse the colors of the preview image.

- [Clear] icon

Click to erase the preview image.

- [Preview] window

Displays a preview image. Drag the rectangle over the image to select an area.

- [Before (RGB)]/[After]

Move the pointer in the preview window to display the color tones at the pointer's position before and after adjustments.

- [Width]/[Height]

Displays the width and height for the selected area in the selected measurement units.



# Windows WIA Driver Settings

- [Paper source]

Select the paper source.

- [Color picture]

Select this setting when scanning in color.

- [Grayscale picture]

Select this setting when scanning in grayscale.

- [Black and white picture or text]

Select this setting when scanning in black and white.

- [Custom Settings]

Select this setting when scanning with [Adjust the quality of the scanned picture] settings applied.



*If settings have been specified with [Adjust the quality of the scanned picture], [Custom Settings] is automatically selected.*

- [Adjust the quality of the scanned picture]

Click this message to display the Advanced Properties dialog box. In the Advanced Properties dialog box, settings can be specified for [Brightness], [Contrast], [Resolution(DPI)], and [Picture type] (select from color, grayscale or black and white).



*These settings are applied when [Custom Settings] is selected.*

- [Page size]

Specify the paper size when [Page source] is set to [Document Feeder].

- Preview window

Displays a preview image. Drag the rectangle over the image to select an area.

- [Preview]

Click to begin scanning a preview image.

- [Scan]

Click to begin scanning.

- [Cancel]

Click to close the WIA driver window.

# Macintosh TWAIN Driver Settings

## Mode settings

- [Mode Settings]

Select [Basic Mode] for specifying basic settings, or select [Advanced Mode] for specifying detailed settings.

The settings that can be specified differ for each mode.

## When [Basic Mode] is selected

The following parameters can be set when [Basic Mode] is selected.

- [Help] icon

Click to display Help information.

- [About] icon

Click to display the software version information.

- [Scan Objective]

Specify the document type.

- [Scan Type]

Specify the scan type.

- [Resolution]

Specify the resolution.

- [Auto Color Adjustment]

Specify the auto color adjustment settings.

- [Auto Deskew]

Specify settings for correcting the skew of the image.

- [Paper source]

Specify the paper source.

When scanning documents from the ADF, select whether to scan only the front side or both sides of the document.

- [Original Size]

Specify the original size.

- [Rotation]

Select the orientation of the image to be scanned.



*If the [Rotate back side] check box is selected, the back side of the image is rotated 180° and scanned. (Applies only if [ADF (2-sided)] is selected.)*

- [Image size]

Shows the data size of the scan image.

- [Close]

Click to close the TWAIN driver window.

- [Prescan]

Click to begin scanning a preview image.

- [Scan]

Click to begin scanning.

- [Clear] icon

Click to erase the preview image.

## When [Advanced Mode] is selected

The following parameters can be set when [Advanced Mode] is selected.

- [Load]

Specify a saved settings file (dat file) for scanning.

- [Save]

Save the current settings as a settings file (dat file).

- [Default]

Return all settings to their defaults.

- Help icon

Click to display the Help.

- About icon

Click to display the software version information.

- [Paper source]

Specify the paper source.

With scanning documents from the ADF, select whether to scan only the front side or both sides of the document.

- [Original Size]

Specify the original size.

- [Scan Type]

Specify the scan type.

■ [Resolution]

Specify the resolution.

■ [Scale]

Specify the enlargement or reduction ratio for the selected area.



*If the resolution is set at 1200 × 1200dpi or higher, a setting larger than 100% cannot be specified.*

■ [Scanning Mode]

Select [Auto] or [Manual]. When [Manual] is selected, a tab appears so that detailed settings can be specified, for example, for [Brightness/Contrast], [Filter], [Curves], [Levels], [Color Balance], and [Hue/Saturation].



*The parameters that can be set differ depending on the scanning mode that is selected.*



*The detailed settings that appear differ depending on the setting selected for [Scan Type].*



*If [Auto] is selected as the scanning mode, scanning from the original glass is performed after a prescan is performed so that a preview image can be checked.*

■ [Image size]

Shows the data size of the scan image.

■ [Rotation]

Select the orientation of the image to be scanned.



*If the [Rotate back side] check box is selected, the back side of the image is rotated 180° and scanned. (Applies only if [ADF (2-sided)] is selected)*

■ [Auto Deskew]

Specify settings for correcting the skew of the image.

■ [Close]

Click to close the TWAIN driver window.

■ [Prescan]

Click to begin scanning a preview image.

■ [Scan]

Click to begin scanning.

■ [AutoCrop] icon

Click to automatically detect the scanning position based on the preview image.

- [Zoom Prescan] icon

Click to rescan the area selected in the preview window and enlarge it to fit the window.

- [Mirror] icon

Click to display a mirror image of the preview image.

- [Tone Reversal] icon

Click to reverse the colors of the preview image.

- [Clear] icon

Click to erase the preview image.

- Preview window

Displays a preview image. Drag the rectangle over the image to select an area.

- [Before (RGB)]/[After]

Move the pointer in the preview window to display the color tones at the pointer's position before and after adjustments.

- [Width]/[Height]

Displays the width and height for the selected area in the selected measurement units.

# Using a Web Service

The scan command can be sent from a computer (Windows 7/Vista/Server 2008) on the network or this machine can scan using a specified operation, and the scan data can be sent to a computer. The settings that must be specified in advance on the computer are described below.

## Settings required to use a Web Service

The following settings are required in order to use a Web Service.

- Install this machine on the computer.
- Specify settings on the machine for using a Web Service.



*Specify the Web Service settings on the machine from the Admin Settings screen. For details, refer to the [Reference Guide].*

## Installing this machine on the computer

### Confirmation before installation

Before installation, make sure that “Network Discovery” (Network and Sharing Center in Control Panel) is enabled.

### Installation procedure

- 1 In the Start button menu, click “Network”.  
The devices connected to the network appear.
- 2 Right-click the scanner icon for this machine, and then click “Install”.
  - Depending on the settings specified on the computer, a UAC (User Account Control) message may appear. Check the information described in the message, and then continue with the procedure.
  - If both scanning and printing using a Web Service have been enabled on this machine, this machine appears as a printer icon.
  - The driver software is automatically installed. After a confirmation message appears, click [Close].
- 3 From the control panel of the machine, select [Scan to Folder] - [Direct Input] - [Web Service Settings], and then check that a destination appears.

## Specifying the scan command from a computer (Web Service)

A computer can send the scan command to this machine, then receive the scan data.

As an example, the procedure for scanning from the Windows Photo Gallery is described below.



*The scan command can also be sent from this machine, where the data will be saved. For details, refer to “With [Web Service Settings]” on page 10-32.*

### Specifying the scan command from a computer

- 1** Start up the application used for scanning.
- 2** In the “File” menu, click “From Scanner or Camera”.
- 3** From the “Select Device” list, select this machine, and then click [OK]. The New Scan window appears.
- 4** Position the document on this machine.
  - Specify the scan settings, and then click [Scan]. Scanning begins, and the scan data is added to the list of image files.





*Scanning with  
the machine*

10



# Initial settings

This machine is equipped with scanning functions for saving data on this machine's hard disk or on a USB memory device, and with network scanning functions for sending scanned image data through the network with E-mail transmissions, FTP transmissions, SMB transmissions, WebDAV transmissions and Web Service transmissions.

- In order to perform an FTP transmission, a connection to the network is required, and parameters must be specified on the [TCP/IP] and [FTP] screens.
- In order to perform an SMB transmission, a connection to the network is required, and parameters must be specified on the [TCP/IP] and [SMB] screens.
- In order to perform a WebDAV transmission, a connection to the network is required, and parameters must be specified on the [TCP/IP] and [WebDAV] screens.
- In order to perform a Web Service transmission, a connection to the network is required, and parameters must be specified on the [TCP/IP] and [WSD Print] screens.
- In order to perform an E-mail transmission, a connection to the network is required, parameters must be specified on the [TCP/IP] and [SMTP] screens, and an E-mail address must be registered for [Administrator Registration].
- For details on specifying network settings, refer to the [Reference Guide].

## Useful functions

- The destinations (recipients) for scan data can be registered as address book destinations or group destinations.
- The destination and scan settings can be registered together as a single program. This is convenient for frequently scanning documents and sending data under the same conditions.

# Performing Scan to E-mail mode operations

## Basic Scan to E-mail operation

The basic procedure for the Scan to E-mail operation, which sends scan data with an E-mail transmission, is described below.

- 1 Press [Scan to E-mail] to display the initial Scan to E-mail mode screen.
- 2 Place the document in the ADF or on the original glass.
  - For details on loading the original document, refer to “Loading a Document” on page 4-36.



*If the document contains more pages than can be loaded into the ADF, set [Settings] - [Original Settings] - [Separate Scan] to [ON] so that the document can be divided and scanned separately. For details, refer to “[Original Settings] - [Separate Scan]” on page 10-5.*



*To scan multiple document pages using the original glass and send them as combined scan data, set [Settings] - [Original Settings] - [Separate Scan] to [ON]. For details on [Separate Scan], refer to “[Original Settings] - [Separate Scan]” on page 10-5.*

- 3 Specify the destination.
  - For details on specifying destinations, refer to “Specifying destinations” on page 10-14.
  - In the initial Scan to E-mail mode screen, press [Mode Check] to check or change the specified destinations.
- 4 If necessary, specify settings for other parameters in the [Settings] screen.
  - For details on the [Simplex/Duplex], [Original Size], [Original Settings], [Color Mode] and [Original Type] parameters available from the [Settings] screen, refer to “Specifying document settings” on page 10-4.
  - For details on the [Background/Density], [Resolution] and [File Settings] parameters available from the [Settings] screen, refer to “Specifying scan settings” on page 10-8.
  - For details on the [Communication] parameters available from the [Settings] screen, refer to “Specifying communication settings” on page 10-12.

## 5 Press the [Start] key.

- Press the [Start (Color)] key to scan in color, or press the [Start (B&W)] key to scan in black and white.



*This machine cannot automatically detect the size of an original document that will be scanned. Before scanning the document, specify its size. If the size of the original document is not correctly specified, some parts of the image may be lost. For details on specifying the size of an original document, refer to “[Original Size]” on page 10-5.*



*If the memory becomes full while the document is being scanned, scanning cannot continue. To send the document pages that have already been scanned, press the [Start] key. To stop the transmission, press the [Stop] key.*

## Specifying document settings

The [Simplex/Duplex], [Original Size], [Original Settings], [Color Mode] and [Original Type] parameters available from the [Settings] screen can be used to specify document settings.

### [Simplex/Duplex]

Select whether double-sided documents are to be scanned when the ADF is used.

Item	Description
[1-sided]	Select this setting when scanning a single-sided document.
[2-sided]	Select this setting when scanning a double-sided document.
[Cover + 2-sided]	Select this setting when scanning a double-sided document with a cover page. Only the front side of the cover page will be scanned, and then both the front and back sides of the remaining pages will be scanned.

## [Original Size]

Specify the size of the document that is to be sent.

Item	Description
[Standard Size]	Select the size of the document.  Select [Letter/Legal] to scan a document containing different page sizes.
[Custom Size]	Specify the size of the document if it is a non-standard size.  Press [X] and [Y], and then type in the document size. [X] can be set between 30 mm and 356 mm (1.18 inches and 14.00 inches); [Y] can be set between 30 mm and 216 mm (1.18 inches and 8.50 inches).

## [Original Settings] - [Separate Scan]

A document can be divided and scanned separately.

The scan operation can be divided into several sessions, for example, when the document contains more pages than can be loaded into the ADF or when the original glass is being used to scan a document containing multiple pages, and then all scanned pages can be sent as a single document.

- 1 Place the document in the ADF or on the original glass.
- 2 Press [Scan to E-mail] to display the initial Scan to E-mail mode screen.
- 3 With [Original Settings] in the [Settings] screen, set [Separate Scan] to [ON].
- 4 Press the [Start] key.  
The document is scanned.
- 5 Place the next document page on the original glass, and then press the [Start] key.
  - Repeat this step until all document pages have been scanned.
- 6 After all pages of the document have been scanned, press [Finish].

## [Original Settings] - [Original Direction]

Specify the orientation of the document.

Item	Description
[Top]	Select this setting when the document is loaded with its top edge at the top.
[Bottom]	Select this setting when the document is loaded with its top edge at the bottom.
[Left]	Select this setting when the document is loaded with its top edge at the left (at the right when placed on the original glass).
[Right]	Select this setting when the document is loaded with its top edge at the right (at the left when placed on the original glass).

## [Original Settings] - [Orig. Binding Position]

Specify the binding position when scanning a double-sided document using the ADF. The orientation of the back sides of the pages differs depending on whether the double-sided document will be bound at the top or at the left.

Item	Description
[Left Bind]	Select this setting to specify a binding position at the left.
[Top Bind]	Select this setting to specify a binding position at the top.
[Auto]	Select this setting to automatically specify the binding position.  If the document length is 297 mm (11.69 inches) or less, a binding position along the long side of the paper is selected.  If the document length is more than 297 mm (11.69 inches), a binding position along the short side of the paper is selected.

## [Color Mode]

Select whether the document will be scanned in color or black and white.

Item		Description
[Color]	[Auto]	Select this setting to automatically detect the color of the document and scan it with the corresponding setting.
	[Full Color]	Select this setting to scan in full color.
[Monochrome]	[Gray Scale]	Select this setting for documents with many halftones, such as in black-and-white photos.
	[Black]	Select this setting for documents with distinct black and white areas, such as in line drawings.



*[Black] may not be available, depending on the setting selected for [File Type].*

## [Original Type]

Select the appropriate image quality setting according to content of the document.

Item	Description
[Text]	Select this setting when scanning documents containing only text.
[Text/Photo]	Select this setting when scanning documents containing a combination of text and photos.
[Photo]	Select this setting when scanning documents containing only photos.

## Specifying scan settings

The [Background/Density], [Resolution] and [File Settings] parameters available from the [Settings] screen can be used to specify scan settings.

### [Background/Density]

Specify the appropriate image quality settings for the document.

Item	Description
[Background Removal]	Select the density of the background color at which documents with a background color are to be scanned. Nine density levels are available for the background color.
[Density]	Select the density at which the document is to be scanned. Nine density levels are available. Select the appropriate density setting according to your document.
[Sharpness]	Select the strength of outlines, for example, on characters and lines, for scanning the document. To scan characters and lines with greater sharpness, select a setting in the + direction. Seven sharpness levels are available.

### [Resolution]

Select the resolution at which the document is to be scanned.

Item	Description
[150×150dpi]	Select this setting to scan the document at 150 × 150 dpi.
[200×200dpi]	Select this setting to scan the document at 200 × 200 dpi.
[300×300dpi]	Select this setting to scan the document at 300 × 300 dpi.
[600×600dpi]	Select this setting to scan the document at 600 × 600 dpi.



*A finer scan has more information to be sent, therefore, the transmission time increases.*



*If [File Type] is set to [Compact PDF], [Resolution] can only be set to [300×300dpi].*



## [File Settings] - [File Type]

Select the file format for the scan data to be saved.

Item	Description
[PDF]	Select this setting to save the data in the PDF format.
[Compact PDF]	Select this setting to save the data compressed more than with the PDF format.
[TIFF]	Select this setting to save data in the TIFF format.
[JPEG]	Select this setting to save the data in the JPEG format.
[XPS]	Select this setting to save data in the XPS format.



*The [File Type] parameter may not be available, depending on the settings selected for [Color Mode] and [Resolution].*



*If [File Type] is set to [Compact PDF], [Resolution] can only be set to [300×300dpi].*

## [File Settings] - [Scan Setting]



Select whether the data is divided into individual pages or multi-page data is created when multiple pages are scanned.

Item	Description
[Single Page]	Select this setting to save the data divided into individual pages.
[Multi Page]	Select this setting to save the scan as multi-page data.

## [File Settings] - [PDF Encrypt]

Specify the encryption settings when [PDF] or [Compact PDF] is selected.

Item		Description
[Encryption Level]	[Yes]	Select this setting to enable encryption. After selecting this setting, set the encryption level to [Low], [Middle] or [High].
	[No]	Select this setting to disable encryption.
[Password]		Type in the password required to open encrypted data. (up to 32 characters)
[Document Permissions]		Type in the password required to change the permissions for a document. (up to 32 characters)

Item	Description
[Details]	<p>If encryption has been enabled, detailed permission settings can be specified.</p> <p> <i>This appears only if [Encryption Level] is set to [Yes] and a password has been specified for [Document Permissions].</i></p>
[Printing Allowed]	<p>Select whether to allow the data to be printed ([Allow]), to prohibit printing ([Restrict]), or to allow printing only at a low resolution ([Low Resolution]).</p>
[Changes Allowed]	<p>Select whether to allow or prohibit document editing, such as signing, entering text and annotating the data, and select the permission level if it is allowed.</p> <p>[Level 1]: Pages can be inserted, deleted and rotated.</p> <p>[Level 2]: Annotations can be created, data can be entered in form fields, and signatures can be added to existing signature fields.</p> <p>[Level 3]: All operations, except page extracting, can be performed.</p> <p>[Level 4]: Data can be entered in form fields, and signatures can be added to existing signature fields.</p> <p>[Level 5]: The page layout can be changed, data can be entered in form fields, and signatures can be added to existing signature fields.</p> <p> <i>Levels 1, 2, 3 and 5 appear only when [Encryption Level] is set to [Low]. Levels 1, 2, 3 and 4 appear when [Encryption Level] is set to [Middle] or [High].</i></p>
[Enable Copying]	<p>Select whether to allow text and images in a document to be copied ([Allow]) or to prohibit it ([Restrict]).</p>

## Specifying communication settings

The [Communication] parameters available from the [Settings] screen can be used to specify settings for E-mail transmissions.

### [Binary Division]

Select whether or not transmission data is divided.

Item	Description
[ON]	Select this setting to divide transmission data.
[OFF]	Select this setting to not divide transmission data.
[Admin. Setting]	The setting specified with [Admin Settings] - [Ethernet] - [Binary Division] is given priority.

### [E-mail Encryption]

Description	
Settings	[ON] / [OFF]
Specify settings for E-mail encryption.	

### [Send Use Signature]

Description	
Settings	[ON] / [OFF]
Select whether or not a digital signature is applied to E-mail messages.	

## [E-mail]

Specify the subject and address of E-mail messages.

Item	Description
[File Name]	Type in the document name for the scan data.
[Subject]	Type in the subject for E-mail messages.
[From]	Specify the sender's address. Select [Administrator E-mail Addr.] or [User Address], or type it in directly.
[Body]	Type in the body text for the E-mail message.

# Specifying destinations

Use any of the following methods to specify destinations.

- “Selecting from registered destinations” on page 10-27
- “Directly typing in the address” on page 10-29
- “Selecting from the log” on page 10-32

## Selecting from registered destinations

An address book destination or group destination can be selected from those previously registered on the machine.



*In order to select a registered destination, address book destinations and group destinations must first be registered on the machine. For details, refer to “Registering destinations” on page 10-34.*



*In [User Settings] - [Machine Settings] - [Scan to E-mail Default Tab], you can specify the default destination tab in the Scan to E-mail mode screen. For details, refer to “[Machine Settings]” on page 3-13.*

## Selecting from the Favorites list

When destinations are registered, they can be specified as [Favorites].

As a default, the [Favorites] destination list appears when the initial Scan to E-mail mode screen is displayed.

Select a destination from the list. To specify multiple destinations for a broadcast transmission, specify all destinations where the data is to be sent.



*The setting for the Favorites list can be specified for a destination when it is registered. For details, refer to “Registering an address book destination” on page 10-35.*

## Selecting with an index search

Destinations can be selected by searching for the index characters specified when each destination was registered.

- 1 In the initial Scan to E-mail mode screen, press .
- 2 Press the desired index tab to search for destinations.
  - If the desired index tab is not displayed, press [→] or [←] until the desired tab appears.
  - To select a group destination, press [Group].
- 3 Select the destination, and then press [OK].



*To specify multiple destinations, specify all destinations where the data is to be sent.*

## Selecting by searching for a destination type or name

Destinations can be selected by searching for their type or name.

- 1 In the initial Scan to E-mail mode screen, press .
- 2 Press [Search].
- 3 Select the method to search for destinations.
  - [Type]: Select the destination type (“Fax”, “E-mail”, etc.).
  - [Name]: Directly enter the name of the destination to be searched for. Type in the name to be searched for, and then press [OK] to display a list of the search results.
- 4 Select the destination, and then press [OK].
  - To specify multiple destinations, select all destinations where the data is to be sent.
- 5 Press [OK].

## Directly typing in the address

To specify a destination that is not registered with the machine, directly type in the address.

- 1 In the initial Scan to E-mail mode screen, press [Direct Input].
- 2 Press [E-mail].
- 3 Type in the E-mail address.
- 4 Press [OK].



*To specify multiple destinations, specify all destinations where the data is to be sent.*



*If [Admin Settings] - [Security Settings] - [Security Details] - [Manual Destination Input] is set to [Restrict], an address cannot be directly typed in. For details on [Manual Destination Input], refer to "[Security Settings]" on page 3-70.*

## Selecting from the log

A destination can be selected from the log of the last five transmissions.

- 1 In the initial Scan to E-mail mode screen, press [Log].
- 2 Select the destination from the list, and then press the [Start] key.



*Only one destination can be selected from the log.*



*The only destinations that appear in the log are those specified after pressing [Direct Input].*

*In addition, destinations specified with broadcast transmissions do not appear in the log.*



*When the machine is turned off, the log is cleared.*



*If [Admin Settings] - [Security Settings] - [Security Details] - [Disable Job History Display] is set to [ON], a destination cannot be selected from the log.*



## Selecting a program destination

Data can be sent with a program destination previously registered on the machine.

Program destinations are registered with destinations where data is frequently sent together with scan settings allowing data to easily be sent without the trouble of specifying the various settings.



*In order to select a program destination, the program destination must first be registered on the machine. For details, refer to "Registering a program destination" on page 10-37.*

- 1** Press [Scan to E-mail] to display the initial Scan to E-mail mode screen.
  - For details on the initial Fax screen, refer to "Initial Scan to E-mail mode screen" on page 2-9.
- 2** Position the document to be scanned.
  - For details on loading the original document, refer to "Loading a Document" on page 4-36.
- 3** Press the [Mode Memory] key.
- 4** Select the desired program destination from the list, and then press [OK]. The settings and destination addresses are recalled.



*Only one program destination can be selected.*

- 5** Press the [Start] key.
  - Press the [Start (Color)] key to scan in color, or press the [Start (B&W)] key to scan in black and white.

# Performing Scan to Folder mode operations

## Basic Scan to Folder operation

The basic procedure for the Scan to Folder operation, which sends scan data to the machine's hard disk, a USB memory device or to a folder on the network, is described below.

**1** Press [Scan to Folder] to display the initial Scan to Folder mode screen.

**2** Place the document in the ADF or on the original glass.

- For details on loading the original document, refer to “Loading a Document” on page 4-36.



*If the document contains more pages than can be loaded into the ADF, set [Settings] - [Original Settings] - [Separate Scan] to [ON] so that the document can be divided and scanned separately. For details, refer to “[Original Settings] - [Separate Scan]” on page 10-21.*



*To scan multiple document pages using the original glass and send them as combined scan data, set [Settings] - [Original Settings] - [Separate Scan] to [ON]. For details on “Separate Scan”, refer to “[Original Settings] - [Separate Scan]” on page 10-21.*

**3** Specify the destination.

- For details on specifying destinations, refer to “Specifying destinations” on page 10-27.
- In the initial Scan to Folder mode screen, press [Mode Check] to check or change the specified destinations.

**4** If necessary, specify settings for other parameters in the [Settings] screen.

- For details on the [Simplex/Duplex], [Original Size], [Original Settings], [Color Mode] and [Original Type] parameters available from the [Settings] screen, refer to “Specifying document settings” on page 10-20.
- For details on the [Background/Density], [Resolution] and [File Settings] parameters available from the [Settings] screen, refer to “Specifying scan settings” on page 10-23.
- For details on the [File Name] parameter available from the [Settings] screen, refer to “Specifying the document name” on page 10-26.
- For details on the [Communication] parameters available from the [Settings] screen, refer to “Specifying communication settings” on page 10-27.

## 5 Press the [Start] key.

- Press the [Start (Color)] key to scan in color, or press the [Start (B&W)] key to scan in black and white.



*This machine cannot automatically detect the size of an original document that will be scanned. Before scanning the document, specify its size. If the size of the original document is not correctly specified, some parts of the image may be lost. For details on specifying the size of an original document, refer to “[Original Size]” on page 10-20.*



*If the memory becomes full while the document is being scanned, scanning cannot continue. To send the document pages that have already been scanned, press the [Start] key. To stop the transmission, press the [Stop] key.*



*To check a scan job, press [Job], and then press [Save] in the [Log] screen.*

## Specifying document settings

The [Simplex/Duplex], [Original Size], [Original Settings], [Color Mode] and [Original Type] parameters available from the [Settings] screen can be used to specify document settings.

### [Simplex/Duplex]

Select whether double-sided documents are to be scanned when the ADF is used.

Item	Description
[1-sided]	Select this setting when scanning a single-sided document.
[2-sided]	Select this setting when scanning a double-sided document.
[Cover + 2-sided]	Select this setting when scanning a double-sided document with a cover page. Only the front side of the cover page will be scanned, and then both the front and back sides of the remaining pages will be scanned.

### [Original Size]

Specify the size of the document that is to be sent.

Item	Description
[Standard Size]	Select the size of the document.  Select [Letter/Legal] to scan a document containing different page sizes.
[Custom Size]	Specify the size of the document if it is a non-standard size.  Press [X] and [Y], and then type in the document size. [X] can be set between 30 mm and 356 mm (1.18 inches and 14.00 inches); [Y] can be set between 30 mm and 216 mm (1.18 inches and 8.50 inches).

## [Original Settings] - [Separate Scan]

A document can be divided and scanned separately.

The scan operation can be divided into several sessions, for example, when the document contains more pages than can be loaded into the ADF or when the original glass is being used to scan a document containing multiple pages, and then all scanned pages can be sent as a single document.

- 1 Place the document in the ADF or on the original glass.
- 2 Press [Scan to Folder] to display the initial Scan to Folder mode screen.
- 3 With [Original Settings] in the [Settings] screen, set [Separate Scan] to [Yes].
- 4 Press the [Start] key.  
The document is scanned.
- 5 Place the next document page on the original glass, and then press the [Start] key.  
Repeat this step until all document pages have been scanned.
- 6 After all pages of the document have been scanned, press [Finish].

## [Original Settings] - [Original Direction]

Specify the orientation of the document.

Item	Description
[Top]	Select this setting when the document is loaded with its top edge at the top.
[Bottom]	Select this setting when the document is loaded with its top edge at the bottom.
[Left]	Select this setting when the document is loaded with its top edge at the left (at the right when placed on the original glass).
[Right]	Select this setting when the document is loaded with its top edge at the right (at the left when placed on the original glass).

## [Original Settings] - [Orig. Binding Position]

Specify the binding position when scanning a double-sided document using the ADF. The orientation of the back sides of the pages differs depending on whether the double-sided document will be bound at the top or at the left.

Item	Description
[Left Bind]	Select this setting to specify a binding position at the left.
[Top Bind]	Select this setting to specify a binding position at the top.
[Auto]	Select this setting to automatically specify the binding position.  If the document length is 297 mm (11.69 inches) or less, a binding position along the long side of the paper is selected.  If the document length is more than 297 mm (11.69 inches), a binding position along the short side of the paper is selected.

## [Color Mode]

Select whether the document will be scanned in color or black and white.

Item	Description
[Color]	[Auto] Select this setting to automatically detect the color of the document and scan it with the corresponding setting.
	[Full Color] Select this setting to scan in full color.
[Mono-chrome]	[GrayScale] Select this setting for documents with many halftones, such as in black-and-white photos.
	[Black] Select this setting for documents with distinct black and white areas, such as in line drawings.



*[Black] may not be available, depending on the setting selected for [File Type].*

## [Original Type]

Select the appropriate image quality setting according to the content of the document.

Item	Description
[Text]	Select this setting when scanning documents containing only text.
[Text/Photo]	Select this setting when scanning documents containing a combination of text and photos.
[Photo]	Select this setting when scanning documents containing only photos.

## Specifying scan settings

The [Background/Density], [Resolution] and [File Settings] parameters available from the [Settings] screen can be used to specify scan settings.

### [Background/Density]

Specify the appropriate image quality settings for the document.

Item	Description
[Background Removal]	Select the density of the background color at which documents with a background color are to be scanned. Nine density levels are available for the background color.
[Density]	Select the density at which the document is to be scanned. Nine density levels are available. Select the appropriate density setting according to your document.
[Sharpness]	Select the strength of outlines, for example, on characters and lines, for scanning the document. To scan characters and lines with greater sharpness, select a setting in the + direction. Seven sharpness levels are available.

## [Resolution]

Select the resolution at which the document is to be scanned.

Item	Description
[150×150dpi]	Select this setting to scan the document at 150 × 150 dpi.
[200×200dpi]	Select this setting to scan the document at 200 × 200 dpi.
[300×300dpi]	Select this setting to scan the document at 300 × 300 dpi.
[600×600dpi]	Select this setting to scan the document at 600 × 600 dpi.



*A finer scan has more information to be sent, therefore, the transmission time increases.*



*If [File Type] is set to [Compact PDF], [Resolution] can only be set to [300×300dpi].*

## [File Settings] - [File Type]

Select the file format for the scan data to be saved.

Item	Description
[PDF]	Select this setting to save the data in the PDF format.
[Compact PDF]	Select this setting to save the data compressed more than with the PDF format.
[TIFF]	Select this setting to save data in the TIFF format.
[JPEG]	Select this setting to save the data in the JPEG format.
[XPS]	Select this setting to save data in the XPS format.



*The [File Type] parameter may not be available, depending on the settings selected for [Color Mode] and [Resolution].*



*If [File Type] is set to [Compact PDF], [Resolution] can only be set to [300×300dpi].*



## [File Settings] - [Scan Setting]



Select whether the data is divided into individual pages or multi-page data is created when multiple pages are scanned.

Item	Description
[Single Page]	Select this setting to save the data divided into individual pages.
[Multi Page]	Select this setting to save the scan as multi-page data.

## [File Settings] - [PDF Encrypt]

Specify the encryption settings when [PDF] or [Compact PDF] is selected.

Item	Description	
[Encryption Level]	[Yes]	Select this setting to enable encryption. After selecting this setting, set the encryption level to [Low], [Middle] or [High].
	[No]	Select this setting to disable encryption.
[Password]	Type in the password required to open encrypted data. (up to 32 characters)	
[Document Permissions]	Type in the password required to change the permissions for a document. (up to 32 characters)	

[Details]	<p>If encryption has been enabled, detailed permission settings can be specified.</p> <p> <i>This appears only if [Encryption Level] is set to [Yes] and a password has been specified for [Document Permissions].</i></p>
[Printing Allowed]	<p>Select whether to allow the data to be printed ([Allow]), to prohibit printing ([Restrict]), or to allow printing only at a low resolution ([Low Resolution]).</p>
[Changes Allowed]	<p>Select whether to allow or prohibit document editing, such as signing, entering text and annotating the data, and select the permission level if it is allowed.</p> <p>[Level 1]: Pages can be inserted, deleted and rotated.</p> <p>[Level 2]: Annotations can be created, data can be entered in form fields, and signatures can be added to existing signature fields.</p> <p>[Level 3]: All operations, except page extracting, can be performed.</p> <p>[Level 4]: Data can be entered in form fields, and signatures can be added to existing signature fields.</p> <p>[Level 5]: The page layout can be changed, data can be entered in form fields, and signatures can be added to existing signature fields.</p> <p> <i>Levels 1, 2, 3 and 5 appear only when [Encryption Level] is set to [Low]. Levels 1, 2, 3 and 4 appear when [Encryption Level] is set to [Middle] or [High].</i></p>
[Enable Copying]	<p>Select whether to allow text and images in a document to be copied ([Allow]) or to prohibit it ([Restrict]).</p>

## Specifying the document name

Specify the document name for the scan data.

Item	Description
[File Name]	Type in the document name for the scan data.

## Specifying communication settings

The [Communication] parameters available from the [Settings] screen can be used to specify settings for sending job completion notifications by E-mail.

### [URL Notification]

Description	
Settings	[ON] / [OFF]
Specify whether or not notifications of completion of a job are to be sent by E-mail.	

### [URL Notification Destination]

Description
Specify the E-mail address where notifications of completion of a job are to be sent.

## Specifying destinations

Use any of the following methods to specify destinations.

- “Selecting from registered destinations” on page 10-27
- “Directly typing in the address” on page 10-29
- “Selecting from the log” on page 10-32

### Selecting from registered destinations

An address book destination or group destination can be selected from those previously registered on the machine.



*In order to select a registered destination, address book destinations and group destinations must first be registered on the machine. For details, refer to “Registering destinations” on page 10-34.*



*In [User Settings] - [Machine Settings] - [Scan to Folder Default Tab], you can specify the default destination tab in the Scan to Folder mode screen. For details, refer to “[Machine Settings]” on page 3-13.*

## Selecting from the Favorites list

When destinations are registered, they can be specified as [Favorites].

As a default, the [Favorites] destination list appears when the initial Scan to Folder mode screen is displayed.

Select a destination from the list. To specify multiple destinations for a broadcast transmission, specify all destinations where the data is to be sent.



*The setting for the Favorites list can be specified for a destination when it is registered. For details, refer to “Registering an address book destination” on page 10-35.*

## Selecting with an index search

Destinations can be selected by searching for the index characters specified when each destination was registered.

- 1 In the initial Scan to Folder mode screen, press .
- 2 Press the desired index tab to search for destinations.
  - If the desired index tab is not displayed, press [→] or [←] until the desired tab appears.
  - To select a group destination, press [Group].
- 3 Select the destination, and then press [OK].
  - To specify multiple destinations, specify all destinations where the data is to be sent.

## Selecting by searching for a destination type or name

Destinations can be selected by searching for their type or name.

- 1 In the initial Scan to Folder mode screen, press .
- 2 Press [Search].
- 3 Select the method to search for destinations.
  - [Type]: Select the destination type (“FTP”, “SMB”, “WebDAV”, etc.).
  - [Name]: Directly enter the name of the destination to be searched for. Type in the name to be searched for, and then press [OK] to display a list of the search results.
- 4 Select the destination, and then press [OK].
  - To specify multiple destinations, select all destinations where the data is to be sent.
- 5 Press [OK].

## Directly typing in the address

To specify a destination that is not registered with the machine, directly type in the address.

### With [FTP]

- 1 In the initial Scan to Folder mode screen, press [Direct Input].
- 2 Press [FTP].
- 3 Specify settings for [Host Name], [File Path], [User Name] and [Password] for the destination computer.
- 4 If necessary, specify settings for other parameters in the [Details] screen.
  - [Pasv]: Select whether or not the PASV mode is used.
  - [Proxy]: Select whether or not a proxy server is used.
  - [Port No.]: Type in the port number. (Range: 1 to 65535)
- 5 Press [OK].



*To specify multiple destinations, specify the various settings, press [Next Dest.], and then specify the settings for the next FTP destination.*



*If [Admin Settings] - [Security Settings] - [Security Details] - [Manual Destination Input] is set to [Restrict], an address cannot be directly typed in. For details on [Manual Destination Input], refer to "[Security Settings]" on page 3-70.*

### With [PC(SMB)]

- 1 In the initial Scan to Folder mode screen, press [Direct Input].
- 2 Press [PC(SMB)].
- 3 Specify settings for [Host Name], [File Path], [User Name] and [Password] for the destination computer.
- 4 If necessary, press [Browse], and then browse to a shared folder to specify it.

**5** Press [OK].



*To specify multiple destinations, specify the various settings, press [Next Dest.], and then specify the settings for the next SMB destination.*



*If [Admin Settings] - [Security Settings] - [Security Details] - [Manual Destination Input] is set to [Restrict], an address cannot be directly typed in. For details on [Manual Destination Input], refer to "[Security Settings]" on page 3-70.*

## **With [WebDAV]**

**1** In the initial Scan to Folder mode screen, press [Direct Input].

**2** Press [WebDAV].

**3** Specify settings for [Host Name], [File Path], [User Name] and [Password] for the destination computer.

**4** If necessary, specify settings for other parameters in the [Details] screen.

- [Port No.]: Type in the port number. (Range: 1 to 65535)
- [Proxy]: Select whether or not a proxy server is used.
- [SSL Setting]: Select whether or not SSL is used.

**5** Press [OK].



*To specify multiple destinations, specify the various settings, press [Next Dest.], and then specify the settings for the next WebDAV destination.*



*If [Admin Settings] - [Security Settings] - [Security Details] - [Manual Destination Input] is set to [Restrict], an address cannot be directly typed in. For details on [Manual Destination Input], refer to "[Security Settings]" on page 3-70.*

## **With [USB Memory]**

**1** Plug the USB memory device into the USB HOST port.

**2** In the initial Scan to Folder mode screen, press [Direct Input].

**3** Press [USB Memory].



*If a USB memory device has not already been plugged in, [USB Memory] is not available.*

**4** Specify a setting for [Document Name].

**5** Press [OK].



*If [Admin Settings] - [Security Settings] - [Security Details] - [Manual Destination Input] is set to [Restrict], an address cannot be directly typed in. For details on [Manual Destination Input], refer to "[Security Settings]" on page 3-70.*



*If [Admin Settings] - [Security Settings] - [Security Details] - [Restrict Scan to USB] is set to [Restrict], [USB Memory] is not available. For details on [Restrict Scan to USB], refer to "[Security Settings]" on page 3-70.*



*With a USB Memory transmission, only one destination can be specified.*

## **With [HDD]**

**1** In the initial Scan to Folder mode screen, press [Direct Input].

**2** Press [HDD].

**3** Press [Save Document].

**4** If user authentication settings have been specified, select [Public] or [Private].

**5** Specify a setting for [Document Name].

**6** Press [OK].



*If [Admin Settings] - [Security Settings] - [Security Details] - [Manual Destination Input] is set to [Restrict], an address cannot be directly typed in. For details on [Manual Destination Input], refer to "[Security Settings]" on page 3-70.*



*With an HDD transmission, only one destination can be specified.*



*Scan data saved on the hard disk can be saved to a computer by copying it with Web Connection. For details, refer to the [Reference Guide].*

## With [Web Service Settings]

With a Web Service transmission, scan data can be sent to a previously registered network computer.

Network computers where this machine is registered as a Web Service scanner appear as destinations. Select a destination.

- 1 In the initial Scan to Folder mode screen, press [Direct Input].
- 2 Press [Web Service Settings].
- 3 Select the destination.
  - If the desired destination is not displayed, press [Search], and then type in the destination name to be searched for.



*If [Admin Settings] - [Security Settings] - [Security Details] - [Manual Destination Input] is set to [Restrict], an address cannot be directly typed in. For details on [Manual Destination Input], refer to "[Security Settings]" on page 3-70.*



*With a Web Service transmission, only one destination can be specified.*



*With WSD scanning on Windows Server 2008 R2/7/Vista/Server 2008, it may not be possible to specify a resolution or document size.*

## Selecting from the log

A destination can be selected from the log of the last five transmissions.

- 1 In the initial Scan to Folder mode screen, press [Log].
- 2 Select the destination from the list, and then press the [Start] key.



*Only one destination can be selected from the log.*



*The only destinations that appear in the log are those specified after pressing [Direct Input].  
In addition, destinations specified with broadcast transmissions do not appear in the log.*



*When the machine is turned off, the log is cleared.*



*If [Admin Settings] - [Security Settings] - [Security Details] - [Disable Job History Display] is set to [ON], a destination cannot be selected from the log.*



## Selecting a program destination

Data can be sent with a program destination previously registered on the machine.

Program destinations are registered with destinations where data is frequently sent together with scan settings allowing data to easily be sent without the trouble of specifying the various settings.



*In order to select a program destination, the program destination must first be registered on the machine. For details, refer to "Registering a program destination" on page 10-37.*

- 1** Press [Scan to Folder] to display the initial Scan to Folder mode screen.
- 2** Position the document to be scanned.
  - For details on loading the original document, refer to "Loading a Document" on page 4-36.
- 3** Press the [Mode Memory] key.
- 4** Select the desired program destination from the list, and then press [OK]. The settings and destination addresses are recalled.



*Only one program destination can be selected.*

- 5** Press the [Start] key.
  - Press the [Start (Color)] key to scan in color, or press the [Start (B&W)] key to scan in black and white.

# Registering destinations

## Destination registration

By registering destinations where scan data is frequently sent, recipients can be recalled allowing a data to easily be sent. With this machine, address book destinations, group destinations and program destinations can be registered.

### Address Book

The information for destinations (E-mail addresses and computer folders, etc.) where data is frequently sent can be registered. A destination can be selected from the address book when scanning. A maximum of 2,000 address book destinations can be registered.

E-mail and SMB address book destinations can be registered from the control panel of this machine or from Web Connection. For details on registering, refer to “Registering an address book destination” on page 10-35.

Computer folder FTP and WebDAV destinations are registered only from Web Connection. For details, refer to the [Reference Guide].

### Group

Multiple address book destinations can be registered together as a group. This is useful when sending the same scan data to multiple destinations. A maximum of 100 group destinations (with a maximum of 500 address book destinations per group) can be registered.

Group destinations are registered from Web Connection. For details on registering, refer to the [Reference Guide].

### Program

Destinations where scan data is frequently sent can be registered together with scan settings (scan settings, document settings, etc.). During scanning, a program destination can be recalled by pressing the [Mode Memory] key in the control panel. A maximum of 400 program destinations can be registered.

For details on registering, refer to “Registering a program destination” on page 10-37.

## Registering an address book destination

The procedure for registering an address book destination for scan data is described below.

E-mail address book destinations can be registered from the control panel of this machine or from Web Connection. The following procedure describes how to register from the control panel of this machine.



*For details on registering from Web Connection, refer to the [Reference Guide].*



*FTP, SMB, and WebDAV destinations can be registered only from the Web Connection. For details on registering from Web Connection, refer to the [Reference Guide].*



*For details on specifying an address book destination to send scan data, refer to "Selecting from registered destinations" on page 10-27.*



*If [Admin Settings] - [Security Settings] - [Security Details] - [Registering and Changing Addr.] is set to [Restrict], a destination cannot be registered from the control panel.*

### Registering an address book destination (E-mail transmission)

- 1 Press the [Utility/Counter] key.
- 2 Press [Address Registration].
- 3 Press [E-mail].
- 4 Press [New].
  - To view the information registered for a destination, select the registered destination, and then press [Mode Check]. To delete the destination, press [Delete] in the [Mode Check] screen.
- 5 Enter the information for the destination, and then press [OK].

Item	Description
[Name]	Type in the registration name for the address book destination. (up to 72 bytes)
[E-mail address]	Type in the E-mail address of the recipient. (up to 320 characters)

[Favorites]	For frequently used destinations, set to [ON]. This displays the destination in the [Favorites] list, allowing it to be found more easily.
[Index]	Select the index characters that will be used to search for the destination.

6 Press [OK].

## Registering Address Book (SMB transmission)

1 Press the [Utility/Counter] key.

2 Press [Address Registration].

3 Press [SMB].

4 Press [New].

- To view the information registered for a destination, select the registered destination, and then press [Mode Check]. To delete the destination, press [Delete] in the [Mode Check] screen.

5 Enter the information for the destination, and then press [OK].

Item	Description
[Name]	Type in the registration name for the address book destination. (up to 72 bytes)
[Connection]	Specify [Host Name], [File Path], [User Name] and [Password] for the destination computer.  If necessary, use [Browse] to search for the shared folder.
[Favorites]	For frequently used destinations, set to [ON]. This displays the destination in the [Favorites] list, allowing it to be found more easily.
[Index]	Select the index characters that will be used to search for the destination.

6 Press [OK].

## Registering a program destination

The procedure for registering a program destination for scan transmissions is described below.

Program destinations can be registered from the control panel of this machine or from Web Connection. The following procedure describes how to register from the control panel of this machine.



*For details on registering from Web Connection, refer to the [Reference Guide].*



*For details on specifying a program destination to send scan data, refer to "Selecting a program destination" on page 10-33.*

- 1** Press [Scan to E-mail] or [Scan to Folder] to display the initial Scan to E-mail or Scan to Folder mode screen.
- 2** Specify settings for the various parameters available from the [Settings] screen.
  - For details on the parameters available from the Settings screen, refer to "Performing Scan to E-mail mode operations" on page 10-3 and "Performing Scan to Folder mode operations" on page 10-18.
- 3** In the control panel, press the [Mode Memory] key.  
The list of program destinations appears.
- 4** Press [Register].
- 5** Specify settings for [Name] and [Dest.] for the program destination, and then press [OK].
  - Press  to display the address book screen. Select a registered destination.
- 6** Press [OK].



*Replacing  
Consumables*

**11**



# Replacing Consumables

---

---

## Note

Failure to follow instructions as outlined in this manual could result in voiding your warranty.

---

---

---

---

## Note

If the toner has run out or the time to replace the transfer belt unit has been reached, an error message appears. Refer to “Error messages” on page 13-39.

When the time to replace the transfer belt unit has been reached, print a configuration page, and then check the status of the consumables. For details on printing the configuration page, refer to “Printing a configuration page” on page 13-2.

---

---

## About Toner Cartridges

Your machine uses four toner cartridges: black, yellow, magenta, and cyan. Handle the toner cartridges carefully to avoid spilling toner inside the machine or on yourself.



*When replacing the toner cartridges, install only new cartridges. If a used toner cartridge is installed, the amount of remaining toner may not appear correctly.*



*Do not open the toner cartridge unnecessarily. If toner is spilled, avoid inhaling it or allowing it to come in contact with your skin.*



*If toner gets on your hands or clothes, immediately wash them with soap and water.*



*If toner was inhaled, move to an area with fresh air, and gargle thoroughly with a large quantity of water. If conditions such as coughing appear, seek professional medical attention.*



*If toner gets in your eyes, immediately flush them with water for at least 15 minutes. If any irritation persists, seek professional medical attention.*



*If toner gets in your mouth, thoroughly rinse it, and then drink 1 to 2 cups of water. If necessary, seek professional medical attention.*



*Store toner cartridges out of the reach of children.*



## Note

---

The use of non-genuine toner cartridges may result in unstable performance. In addition, any damage caused by the use of non-genuine toner cartridges is not covered by the warranty, even if it occurs during the warranty period. (Although damage is not certain to result from using non-genuine toner cartridges, we strongly recommend that you use genuine toner cartridges.)

---

Keep toner cartridges:

- In their packaging until you're ready to install them.
- In a cool, dry location away from sunlight (due to heat).

*The maximum storage temperature is 35°C (95°F) and the maximum storage humidity is 85% (noncondensing). If the toner cartridge is moved from a cold place to a warm, humid place, condensation may occur, degrading print quality. Allow the toner to adapt to the environment for about one hour before use.*

- Level during handling and storage.

*Do not turn cartridges upside down; the toner inside the cartridges may become caked or unequally distributed.*

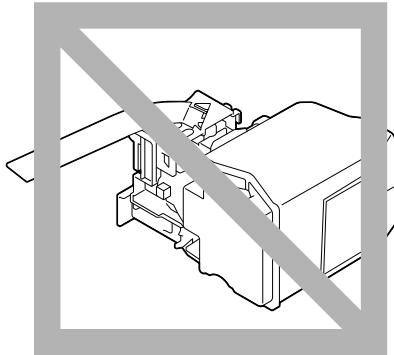

- Away from salty air and corrosive gases such as aerosols.

# Replacing a Toner Cartridge

## Note

---

**Be careful not to spill toner while replacing a toner cartridge. If toner spills, immediately wipe it off with a soft, dry cloth.**

---

When the toner is empty, the message [Replace Toner (x)] appears in the touch panel.

Follow the instructions below to replace the toner cartridge. As an example, the procedure for replacing the yellow toner cartridge is described below.

- 1 Open the machine's front cover.

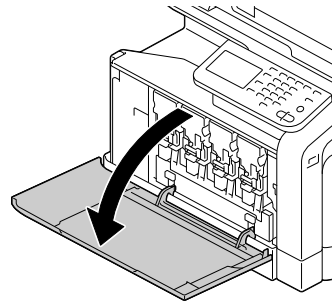
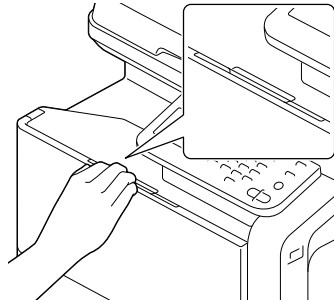

- 2 Pull the front lever of the color toner cartridge indicated to the left.

The replacement procedure for the toner cartridge is the same for all colors (yellow: Y, magenta: M, cyan: C, and black: K).

The following instructions show the procedure to replace the toner cartridge (Y).

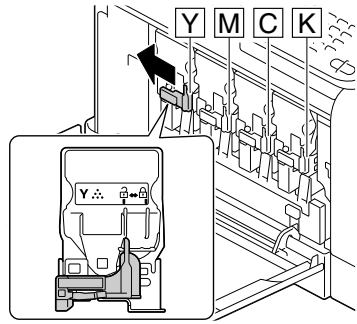

- 3 Grab the handle of the toner cartridge to be replaced, and then pull out the cartridge.

The following instructions show the procedure to replace the toner cartridge (Y).

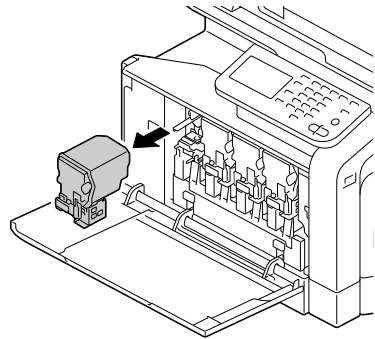

---

## Note

**Dispose of the used toner cartridge according to your local regulations. Do not burn the toner cartridge. For details, refer to “About Toner Cartridges” on page 11-2.**

---

- 4 Check the color of the new toner cartridge to be installed.

- 5** Remove the toner cartridge from the bag.

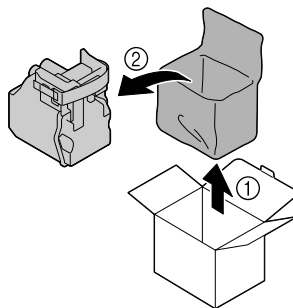

- 6** Shake the cartridge to distribute the toner.

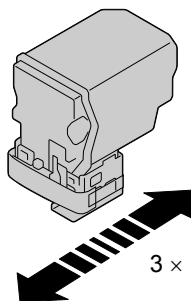

- 7** Peel off the protective film from the right side of the toner cartridge.

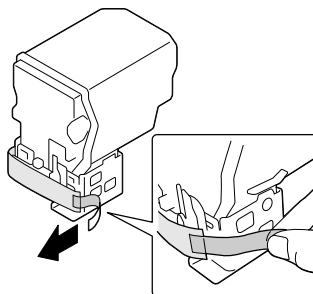

- 8** Make sure that the toner cartridge is the same color as the machine compartment, and then insert the toner cartridge into the machine.



*Fully insert the toner cartridge.*

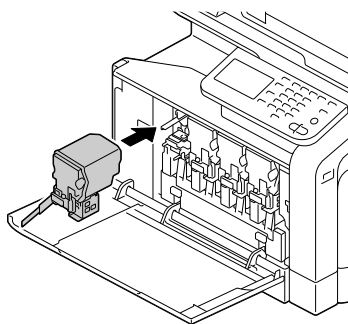

- 9** Pull the lever to the right to lock it in place.



*The front lever should be securely returned to its original position; otherwise, the front cover of the machine cannot be closed.*



*If it is difficult to operate the lever, push it in.*

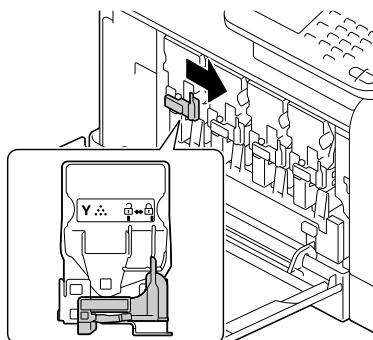

- 10** Make sure that the toner cartridge is securely installed, and then peel off the protective film.

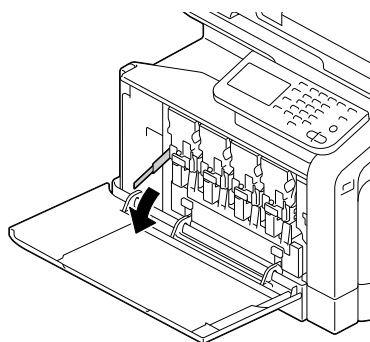

# 11 Close the front cover.

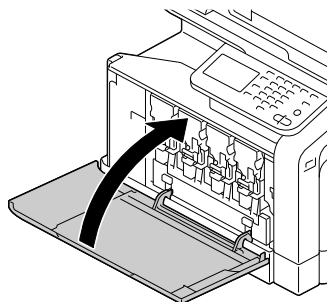

*When closing the front cover, press the area of the cover with small projections.*

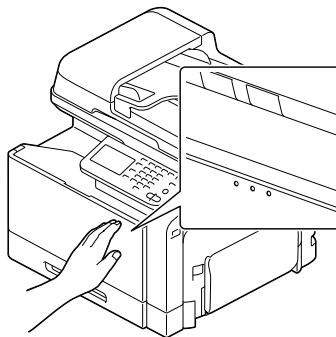

## Replacing a Imaging Unit

### Note

---

Do not touch the OPC drum surface. This could lower image quality.

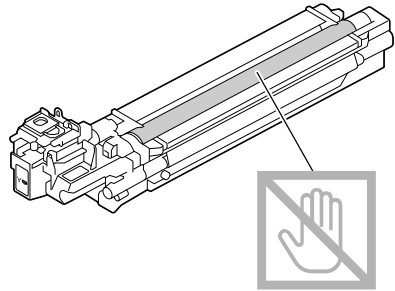

---

If the messages [Replace Imaging Unit] appear, replace the specified imaging unit. As an example, the procedure for replacing the black imaging unit is described below.

- 1 Check the message window to see which color imaging unit needs replacing.

- 2 Open the machine's front cover.

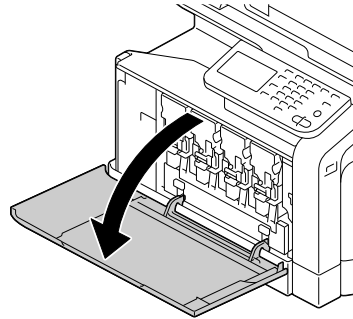
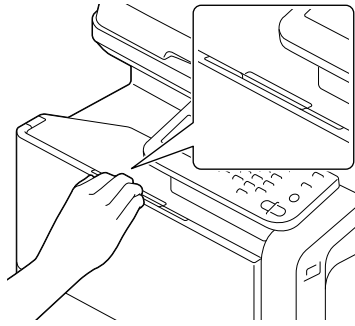

- 3 Pull the front lever of the color toner cartridge indicated to the left.

The replacement procedure for the imaging unit is the same for all colors (yellow: Y, magenta: M, cyan: C, and black: K).

The following instructions show the procedure to replace the toner cartridge (K).

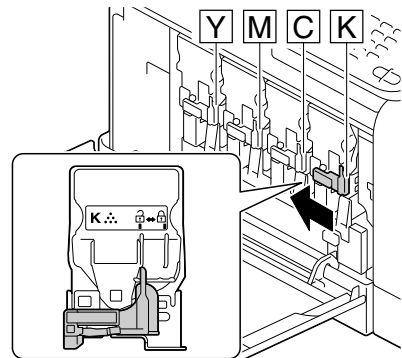



- 4** Grab the handle of the toner cartridge to be removed, and then pull out the cartridge.



*Do not tilt removed toner cartridge, otherwise toner may spill.*

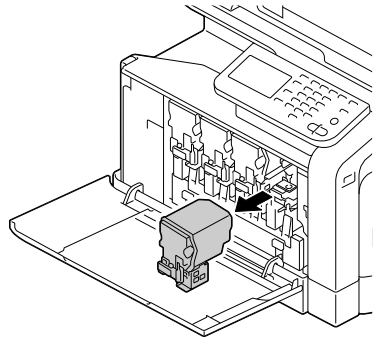

- 5** Pull up the waste toner bottle to unlock it.

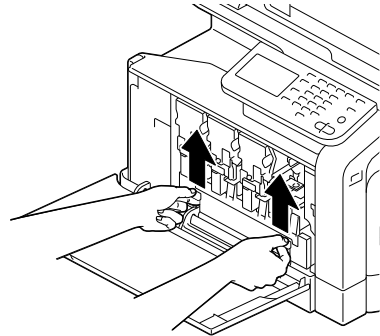

- 6** Grab the left and right handles of the waste toner bottle, and then slowly pull out the bottle.



*Do not tilt removed waste toner box, otherwise waste toner may spill.*

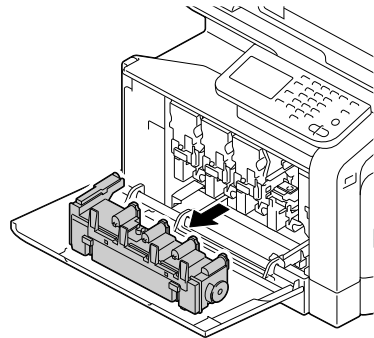

- 7 While pressing down the area marked “Push” on the imaging unit to be replaced, slide the unit completely out of the machine.

The following instructions show the procedure to replace the imaging unit (K).

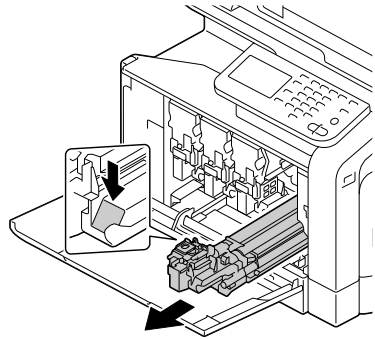

---

### Note

---

**Dispose of the used imaging unit according to your local regulations. Do not burn the imaging unit.**

---

- 8 Check the color of the new imaging unit to be installed.



*In order to prevent toner from spilling, leave the imaging unit in the bag until step 7 is being performed.*

- 9 Remove the imaging unit from the bag.



- 10 Hold the imaging unit with both hands, and then shake it twice as shown in the illustration.



*Do not grab the bottom of the bag; otherwise, the imaging unit may be damaged, resulting in decreased print quality.*

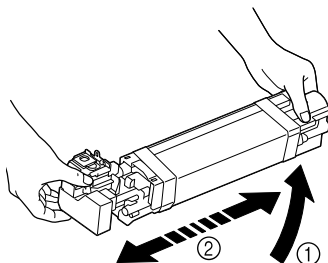
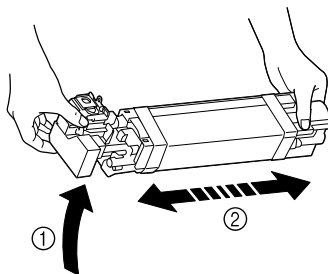

- 11 Remove the protective cover from the imaging unit.  
Remove all packing tape from the imaging unit

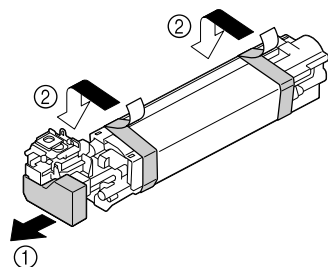

- 12** Remove the paper from the imaging unit.  
Remove the protective cover from the imaging unit.

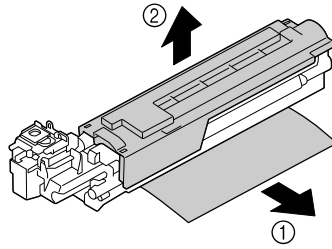

- 13** Make sure that the new imaging unit to be installed is the same color as the machine compartment, and then install the imaging unit in the machine.

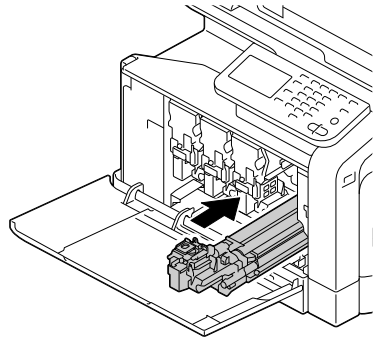

- 14** Press in on the waste toner bottle until it locks into place.

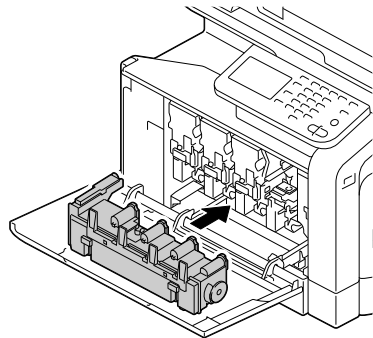

- 15** Make sure that the toner cartridge is the same color as the machine compartment, and then insert the toner cartridge into the machine.



*Fully insert the toner cartridge.*

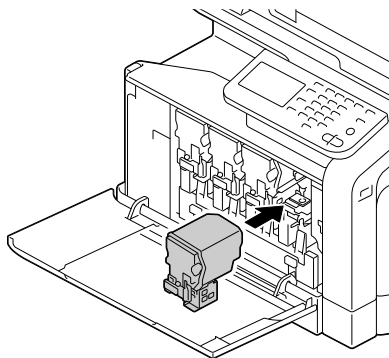

- 16** Pull the lever to the right to lock it in place.



*The front lever should be securely returned to its original position; otherwise, the front cover of the machine cannot be closed.*



*If it is difficult to operate the lever, push it in.*

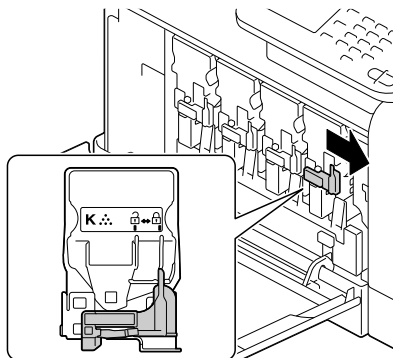

17 Close the front cover.

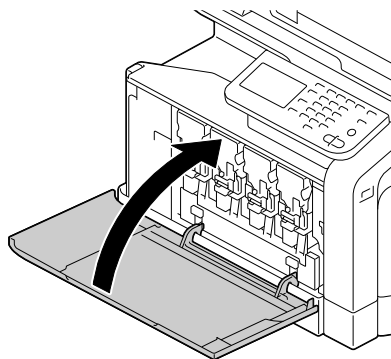

*When closing the front cover, press the area of the cover with small projections.*

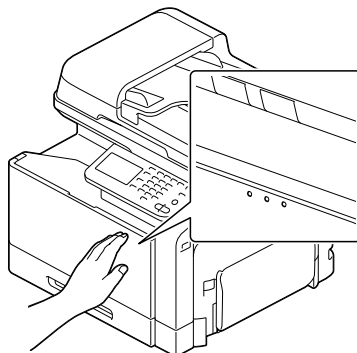

## Replacing the Waste Toner Bottle

When the waste toner bottle becomes full, the message [Waste Toner Box Full] appears in the message window. The machine stops and will not start again until the waste toner bottle is replaced.

- 1 Open the machine's front cover.

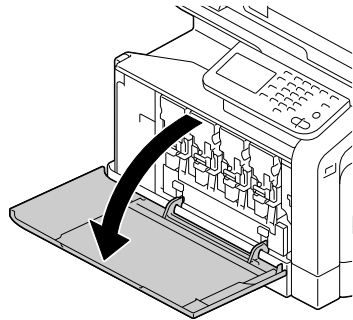
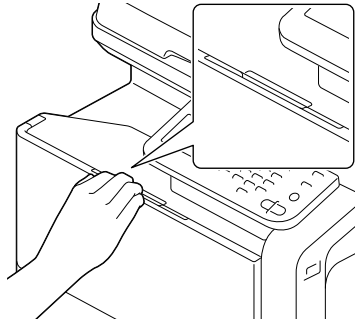

- 2 Pull up the waste toner bottle to unlock it.

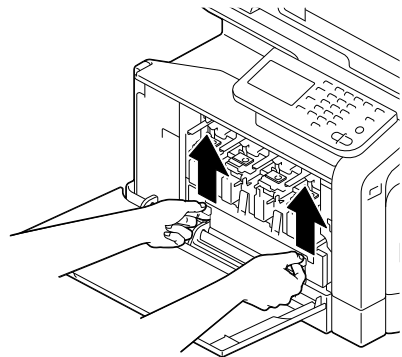

- 3 Grab the left and right handles of the waste toner bottle, and then slowly pull out the bottle.



*Do not tilt removed waste toner box, otherwise waste toner may spill.*

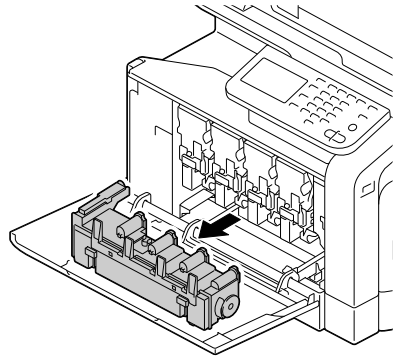

- 4 Remove the new waste toner bottle from its packaging. Insert the used waste toner bottle into the plastic bag included in the box, and then box it up.

### **Note**

---

**Dispose of the used waste toner bottle according to your local regulations. Do not burn the waste toner bottle.**

---

- 5 Press in on the waste toner bottle until it locks into place.

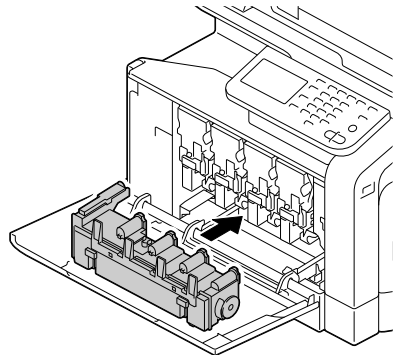



**6** Close the front cover.

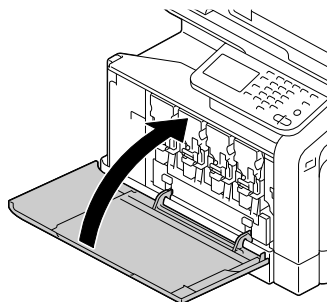

*When closing the front cover, press the area of the cover with small projections.*

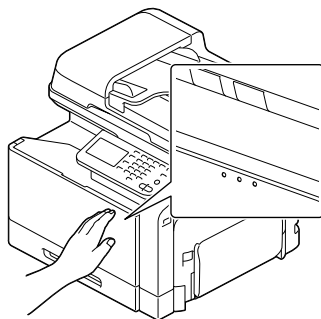

*If the waste toner bottle is not fully inserted, the front cover cannot be closed.*

## Replacing the Transfer Roller

When the time to replace the transfer roller is reached, the message [Replace transfer roller unit.] appears. Printing can continue even after this message appears; however, since the print quality is reduced, the transfer roller should be replaced immediately.

- 1 Pull the lever, and then open the right door.



*Before opening the right door, fold up Tray 1.*

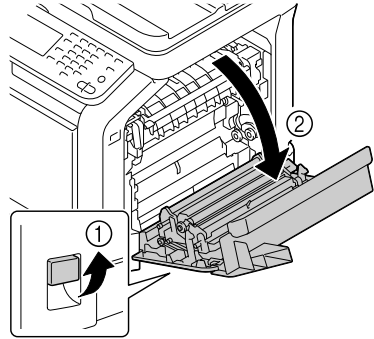

- 2 While pushing the levers to the inside, move the roller presser toward you.

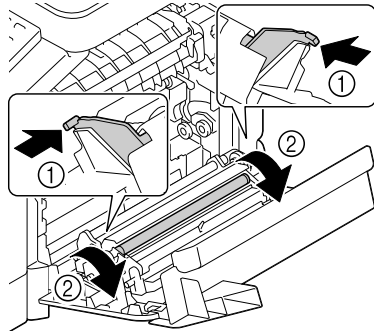

- 3** While continuing to press the levers, remove the transfer roller.

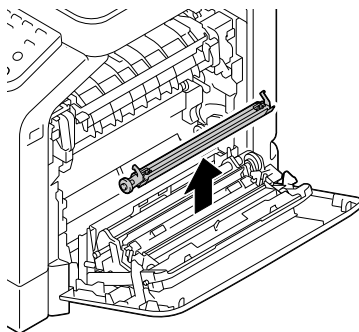

- 4** Prepare a new transfer roller.  
**5** While pressing the levers, insert the shaft of the transfer roller into the bearings.

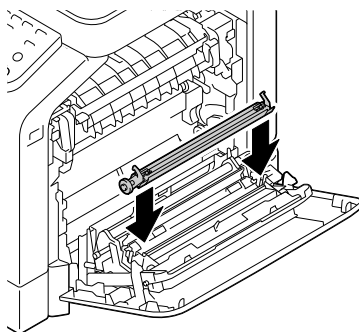

- 6** Move the levers away from you until it snaps into place.

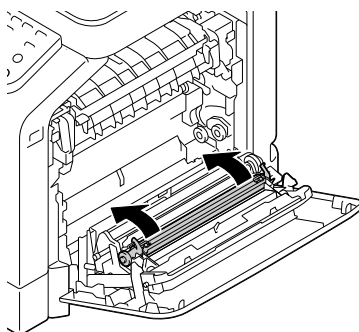

- 7 Close the right door.

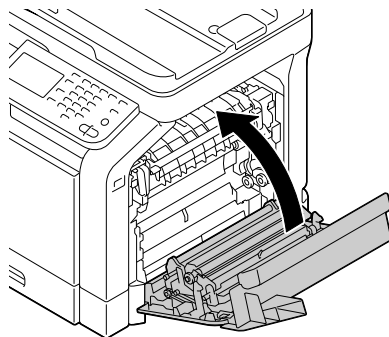

- 8 Reset the counter in the [Admin Settings]/[Maintenance Menu]/[Supplies]/[Consumables Replace]/[Transfer Roller Unit] menu.

## Replacing the Transfer Belt Unit

When the time to replace the transfer belt unit is reached, the message [Replace image transfer belt.] appears. Printing can continue even after this message appears; however, since the print quality is reduced, the transfer belt unit should be replaced immediately.

- 1 Turn off the machine and disconnect the power cord and interface cover.

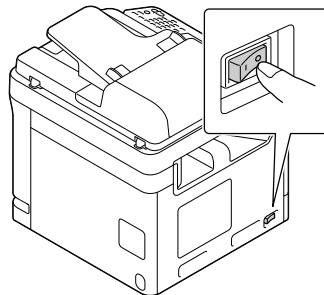

**2** Open the machine's front cover.

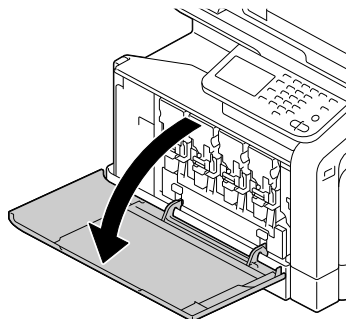
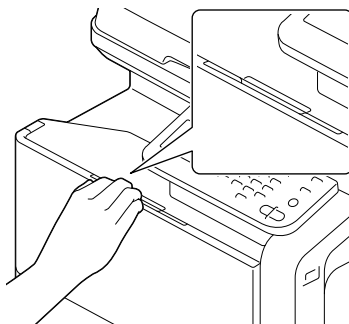

**3** Remove the all toner cartridges, all imaging units and waste toner bottle.



*For details on removing the toner cartridges, imaging units or waste toner bottle, refer to "Replacing a Toner Cartridge" on page 11-4 or "Replacing a Imaging Unit" on page 11-9.*



*Cover the removed imaging unit to protect it from direct sunlight.*



*Do not tilt removed toner cartridge, otherwise toner may spill.*



*Do not tilt removed waste toner box, otherwise waste toner may spill.*

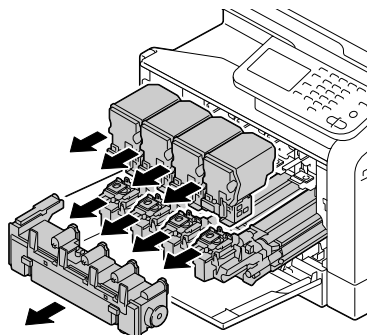

- 4** Pull the lever, and then open the right door.

 *Before opening the right door, fold up Tray 1.*

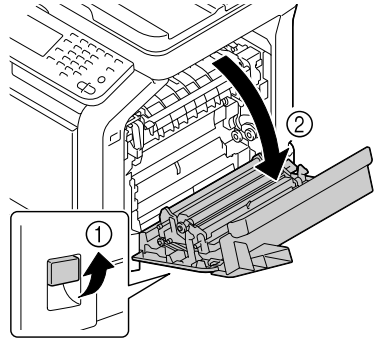

- 5** Remove the top part of the right door.

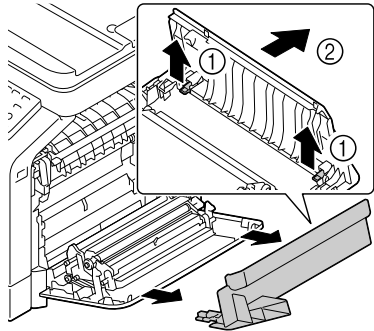

- 6** Insert the protective sheet into the unit in the direction of the arrow until it stops.

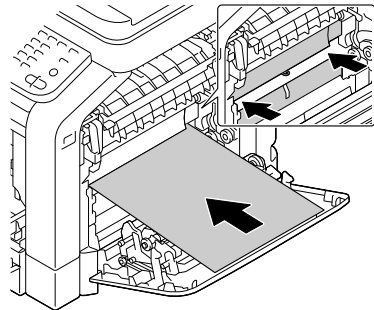

**7** Push down the guides.

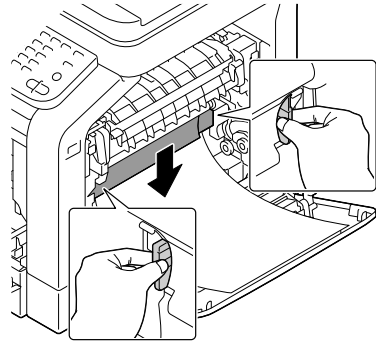

**8** Hold the handles, and then carefully pull out the transfer belt unit.



*Be sure to keep the transfer belt level; otherwise, the transfer belt may be scratched.*

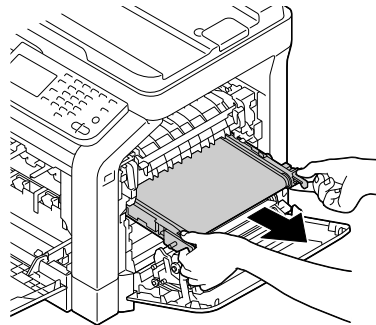

**9** Prepare a new transfer belt unit.



*Be careful not to touch the surface of the belt.*



*Do not remove the blue lever.*

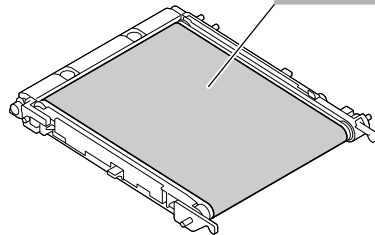

- 10 Remove the protective cover from the new transfer belt unit.

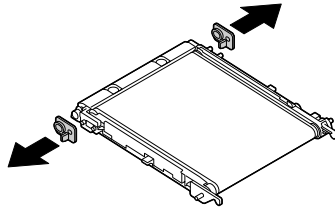

- 11 Insert the new transfer belt unit along the rails.

 *Fully insert it until it locks into place.*

 *Be sure to keep the transfer belt level; otherwise, the transfer belt may be scratched.*

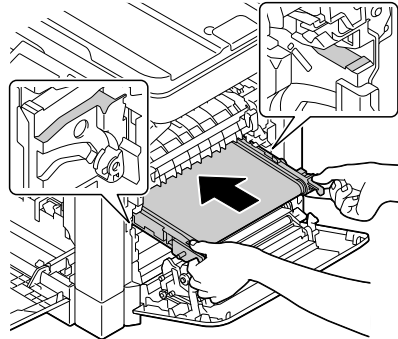

- 12 Push up the guides.

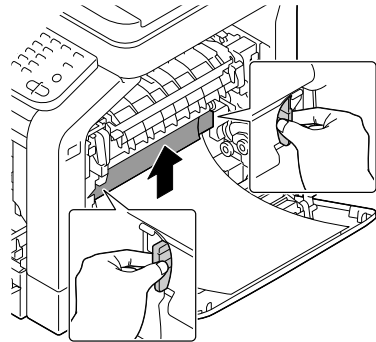



**13** Pull out the protective sheet.

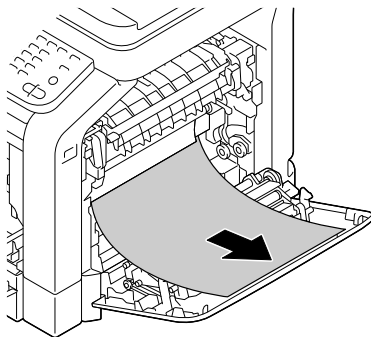

**14** Install the top part of the right door.

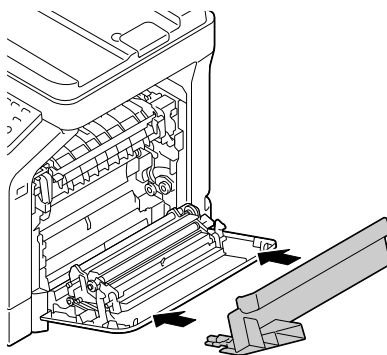

**15** Close the right door.

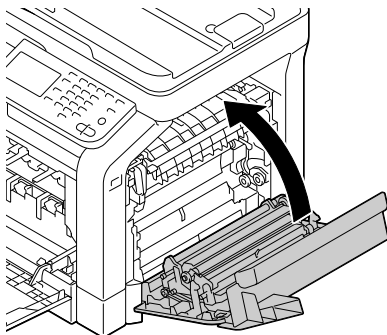

- 16** Install the all toner cartridges, all imaging units and waste toner bottle.



*For details on installing the toner cartridges, imaging units or waste toner bottle, refer to "Replacing a Toner Cartridge" on page 11-4 or "Replacing a Imaging Unit" on page 11-9.*

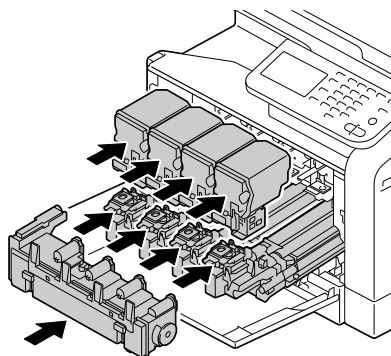

- 17** Close the front cover.

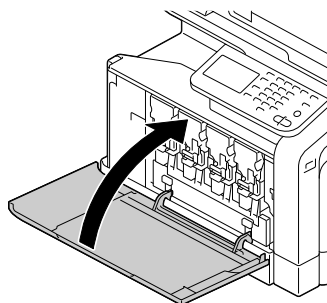

*When closing the front cover, press the area of the cover with small projections.*

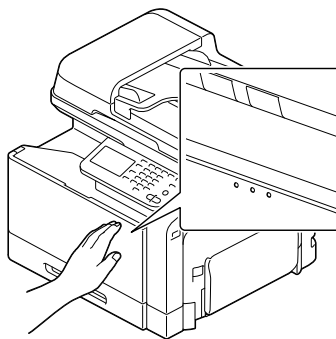

- 18** Reconnect the power cord, and turn on the machine.

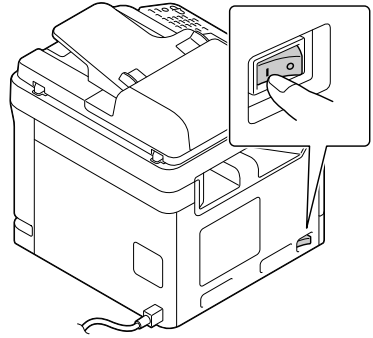

- 19** Reset the counter in the [Admin Settings]/[Maintenance Menu]/[Supplies]/[Consumables Replace]/[Transfer Belt Unit] menu.

## Replacing the Backup Battery

When the backup battery is at its end of life, the machine's date and time cannot be retained. Follow the procedure described below to replace the backup battery.

### Note

---

**Only use the coin-shaped 3V lithium battery CR2032. It's very important to protect the machine controller board and any associated circuit boards from electrostatic damage. Before performing this procedure, review the antistatic caution on page 11-38. In addition, always handle circuit boards by the edges only.**

---

- 1 Turn off the machine and disconnect the power cord and interface cables.

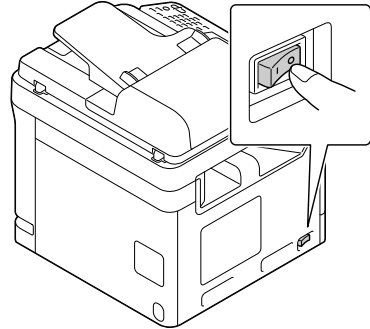

- 2 Remove the cover.

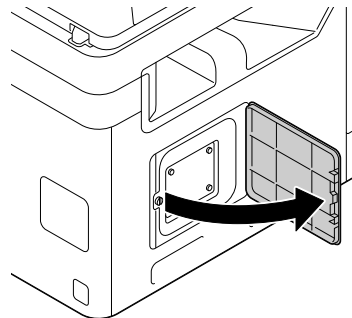

**3** Using a coin, remove a screw.

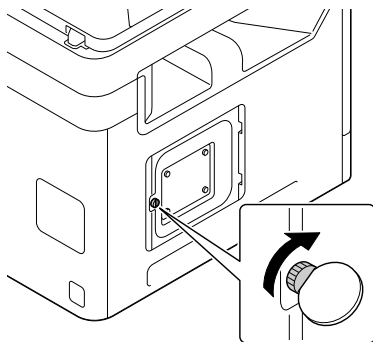

**4** Open the cover.

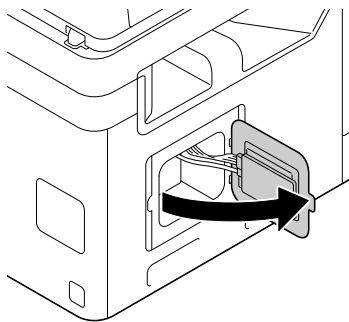

**5** Remove the hook, and then remove the backup battery.

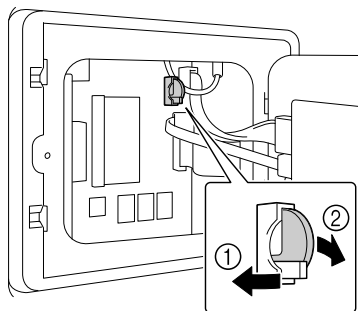

- 6 Remove the hook, and then insert a new backup battery.

 *When inserting the new backup battery, be sure that the + side faces toward the left.*

 *Risk of explosion if battery is replaced by an incorrect type. Dispose of used batteries according to your local regulations. Do not burn the backup battery.*

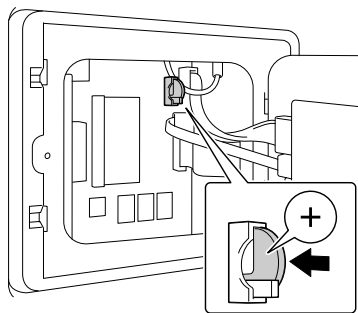

- 7 Reinstall the panel and tighten a screw.
- 8 Install the cover.
- 9 Reconnect all interface cables.
- 10 Reconnect the power cord, and turn on the machine.

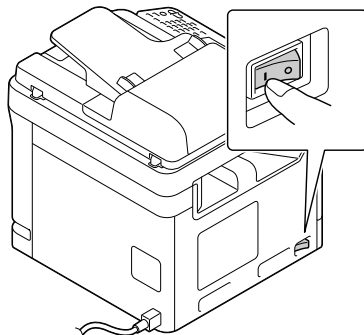

- 11 Use [Date(XX. XX. XX)] on the [Admin Settings]/[Machine Settings]/[Date & Time Settings] menu to set the date, and use [Time] on the [Admin Settings]/[Machine Settings]/[Date & Time Settings] menu to set the time.

## Replacing the Fuser Unit

When the time to replace the fuser unit is reached, the message [Replace fusing unit.] appears. Printing can continue even after this message appears; however, since the print quality is reduced, the fuser unit should be replaced immediately.

- 1 Turn off the machine.

### Note

**There are extremely hot parts within the machine. Before replacing the fuser unit, wait about 20 minutes after turning off the machine, and then check that the fusing section has reached room temperature, otherwise, you may get burnt.**

- 2 Pull the lever, and then open the right door.



*Before opening the right door, fold up Tray 1.*

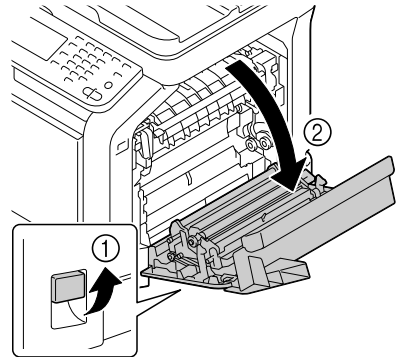

- 3 Open the fuser unit cover.

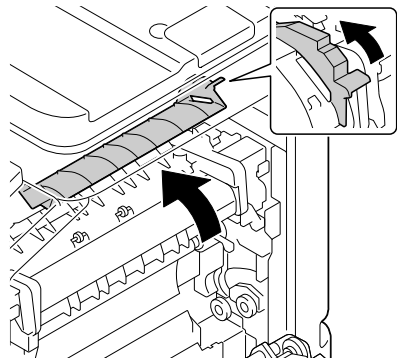

**4** Pull down the 2 levers.

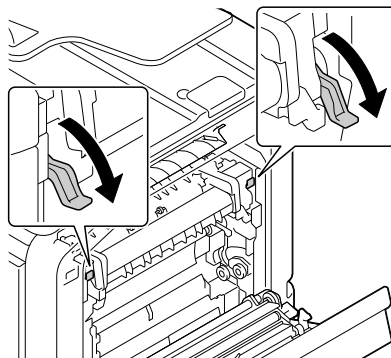

**5** Remove the fuser unit.

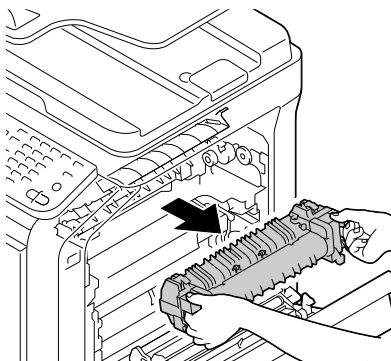

**6** Prepare a new fuser unit.



*Be careful not to touch the surface of the fuser roller.*

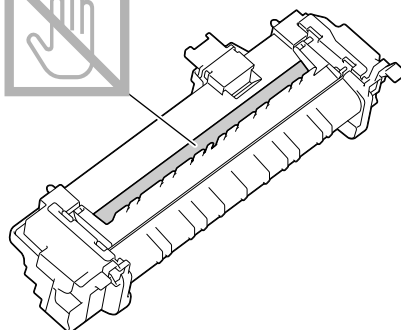



**7** Lift up the 2 levers.

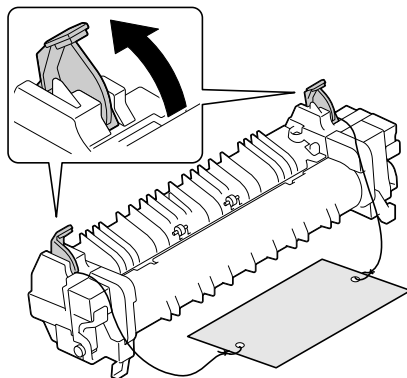

**8** Remove the packing material.

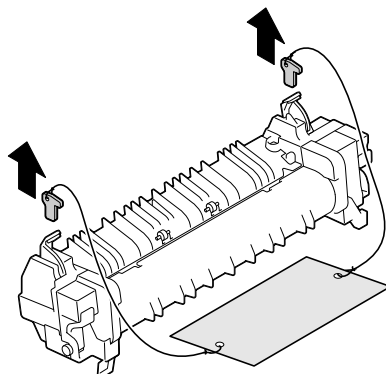

**9** Push down the 2 levers.

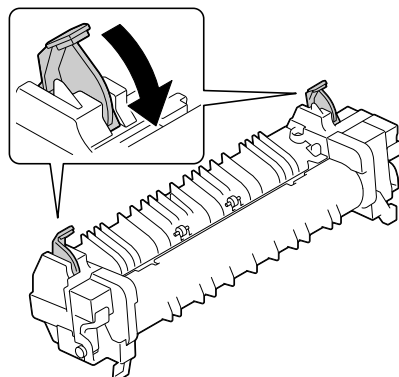

- 10 Pull down the 2 levers of a new fuser unit.

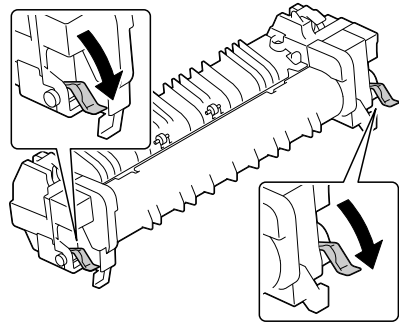

- 11 Insert the fuser unit until it locks into place.

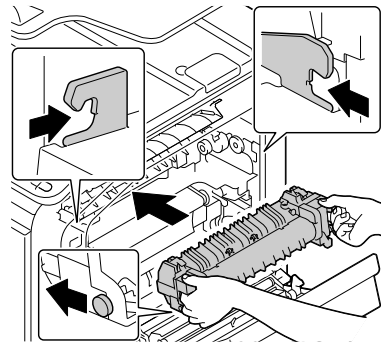

- 12 Lift up the 2 levers.

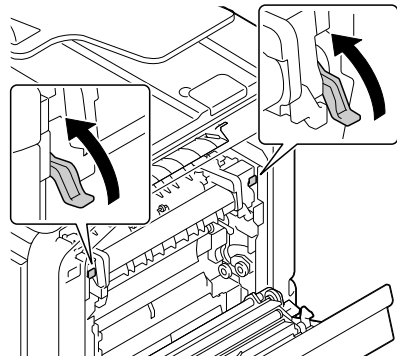

**13** Close the fuser unit cover.

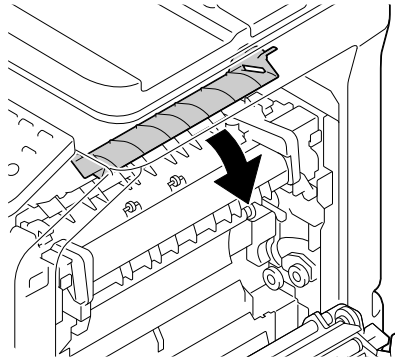

**14** Close the right door.



*If the door cannot be closed, check that the fuser unit is fully inserted.*

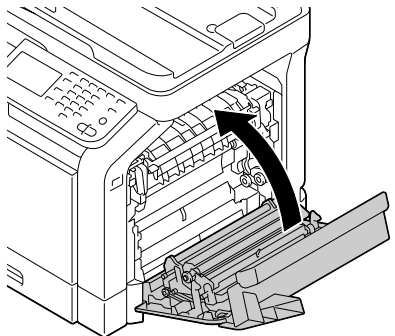

**15** Reset the counter in the [Admin Settings]/[Maintenance Menu]/[Supplies]/[Consumables Replace]/[Fusing Unit] menu.

# Antistatic Protection

## **Note**

---

---

It's very important to protect the printer controller board from electrostatic damage while performing any task involving the controller board.

Turn off all power switches first. If an antistatic wrist strap is provided in your printer option kit, attach one end of it to your wrist and the other end to the bare metal chassis on the back of your printer. Never attach the wrist strap to any piece of equipment with an electrical current present. Plastic, rubber, wood, painted metal surfaces, and telephones are not acceptable grounding points.

If you don't have an antistatic wrist strap, discharge your body's static electric charge by touching a grounded surface before you handle any printer boards or components. Also avoid walking around after grounding yourself.

---

---

*Maintenance* **12**



# Maintaining the machine



## CAUTION

**Read all caution and warning labels carefully, making sure to follow any instructions contained in them. These labels are located on the inside of the machine's covers and the interior of the machine body.**

Handle the machine with care to preserve its life. Abuse handling may cause damage and void your warranty. If dust and paper scraps remain on the inside or outside of the machine, machine performance and print quality will suffer, so the machine should be cleaned periodically. Keep the following guidelines in mind.



## WARNING!

**Turn off the machine, unplug the power cord, and disconnect all interface cables before cleaning. Do not spill water or detergent into the machine; otherwise the machine will be damaged and an electric shock may occur.**



## CAUTION

**The fuser unit is hot. When the right door is opened, the fuser unit temperature drops gradually (one hour wait time).**



- Be careful when cleaning the inside of the machine or removing media misfeeds, as the fuser unit and other internal parts may be very hot.
- Do not place anything on top of the machine.
- Use a soft cloth to clean the machine.
- Never spray cleaning solutions directly on the machine's surface; the spray could penetrate through the air vents of the machine and damage the internal circuits.
- Avoid using abrasive or corrosive solutions or solutions that contain solvents (such as alcohol and benzene) to clean the machine.
- Always test any cleaning solution (such as mild detergent) on a small inconspicuous area of your machine to check the solution's performance.
- Never use sharp or rough implements, such as wire or plastic cleaning pads.
- Always close the machine's covers gently. Never subject the machine to vibration.

- Do not cover the machine immediately after using it. Turn it off and wait until it cools down.
- Do not leave the machine's covers open for any length of time, especially in well-lit places; light may damage the imaging units.
- Do not open the machine during printing.
- Do not tap media stacks on the machine.
- Do not lubricate or disassemble the machine.
- Do not tilt the machine.
- Do not touch the electrical contacts, gears, or laser devices. Doing so may damage the machine and cause the print quality to deteriorate.
- Keep media in the output tray at a minimum level. If the media is stocked too high, your machine may experience media misfeeds and excessive media curl.
- Make sure two people are available to lift the machine when moving it.  
Keep the machine level to avoid toner spillage.

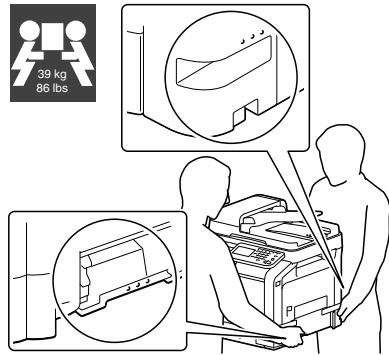

- When lifting the machine, fold up Tray 1, and then lift the machine as shown in the illustration at the right.

If the optional lower feeder unit is installed, move it and the machine separately. Do not grasp the grip of Tray 3, or the right side cover; otherwise, the lower feeder unit may be damaged.

- If you get toner on your skin, wash it off with cool water and a mild soap.



## CAUTION

**If you get toner in your eyes, wash it out immediately with cool water and consult a doctor.**

- Make sure any parts removed during cleaning are replaced before you plug in the machine.

# Cleaning the machine



## CAUTION

Be sure to turn off the machine and unplug the power cord before cleaning.

### Exterior

Control Panel

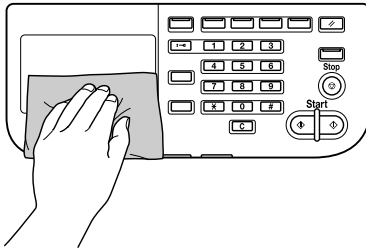

Ventilation Grill

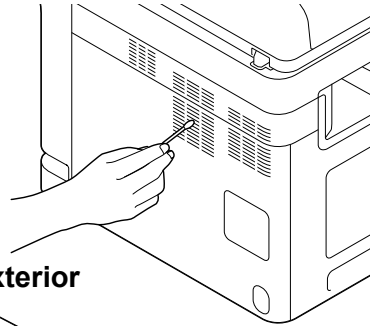

Machine Exterior

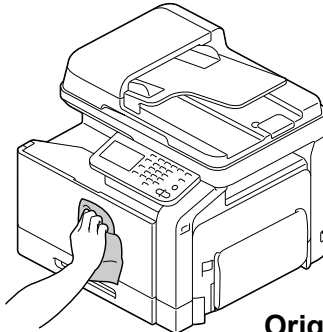

Original Glass

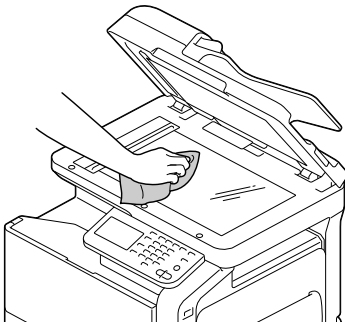

Original Cover Pad

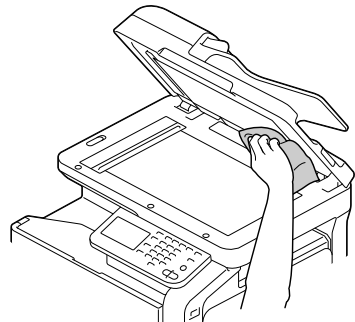



## Media Rollers

The accumulation of paper dust and other debris on the media rollers can cause media-feeding problems.

### Cleaning the Media Feed Rollers (Manual Feed Tray)

1 Open Tray 1.

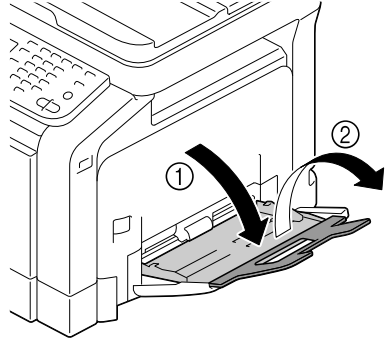

2 Press down on the center of the paper-lifting plate until the left and right locking tabs (white) lock into place.

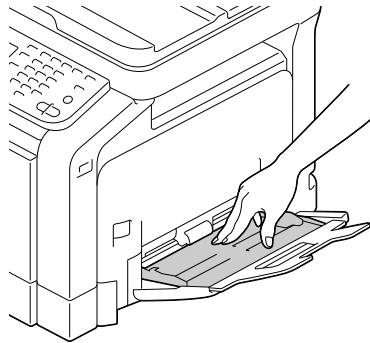

- 3** Clean the media feed rollers by wiping them with a soft, dry cloth.

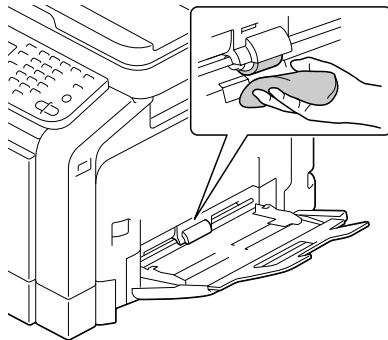

- 4** Close the tray.

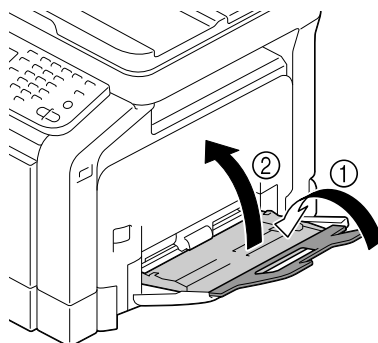

## Cleaning the Media Feed Rollers for Tray 2/3/4

- 1 Pull out the tray.

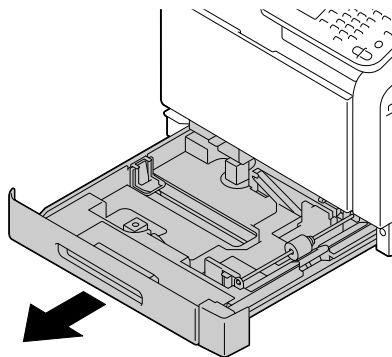

- 2 Clean the media feed rollers by wiping them with a soft, dry cloth.

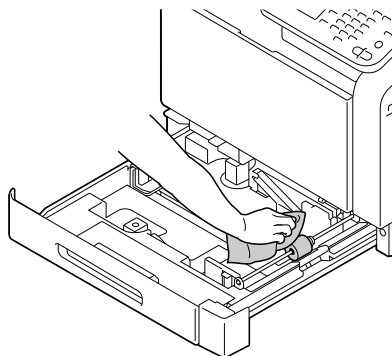

- 3 Close the tray.

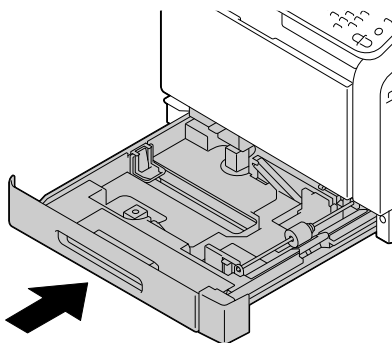

## Cleaning the Media Transfer Rollers for Tray 3/4

- 1 Open the right side cover of Tray 3 or Tray 4.



*Before opening the right side cover of Tray 3 or Tray 4, fold up Tray 1.*

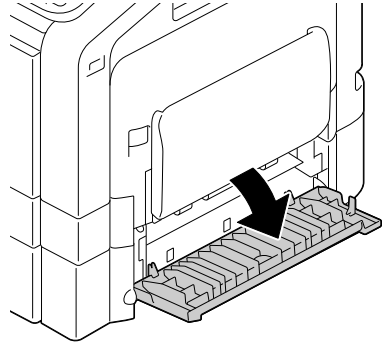

- 2 Clean the media transfer rollers by wiping them with a soft, dry cloth.

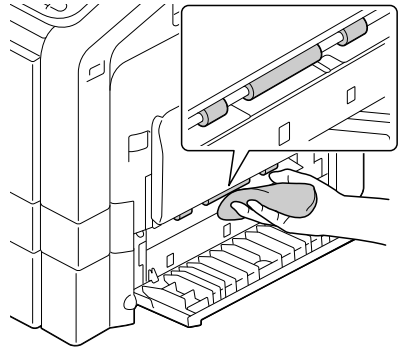

- 3 Close the right side cover of Tray 3 or Tray 4.

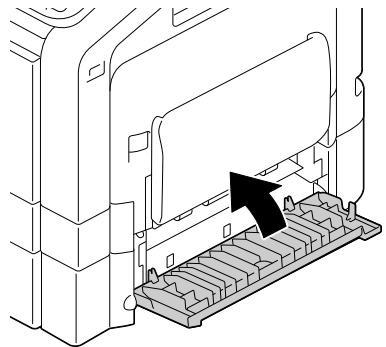

## Cleaning the Media Feed Rollers for the ADF

- 1 Open the ADF feed cover.

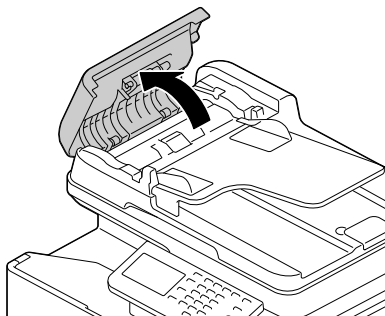

- 2 Clean the media feed rollers by wiping them with a soft, dry cloth.

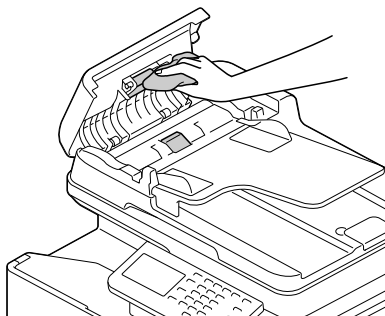

- 3 Close the ADF feed cover.

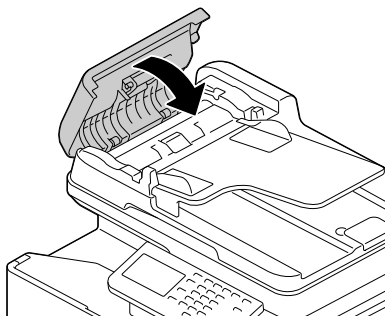

## Cleaning the Laser Lens

This machine is constructed with four laser lenses. Clean all lenses as described below. The laser lens cleaning tool should be attached to the inside of the tray 2.

- 1 Pull out the tray 2.

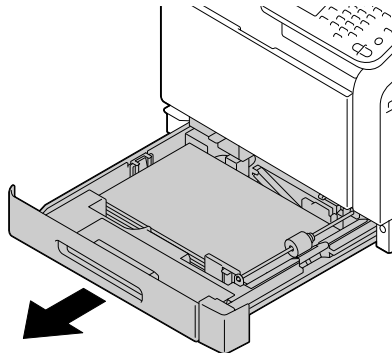

- 2 Remove the cover.



*Since the cover will be used later, do not return it to its original position.*

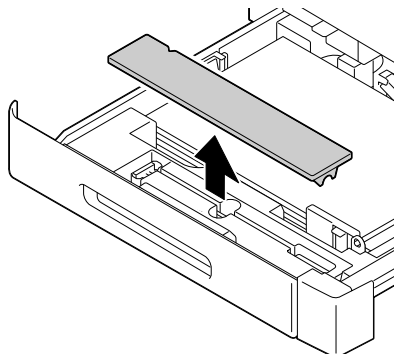

- 3 Remove the cleaning tool from the tray 2.

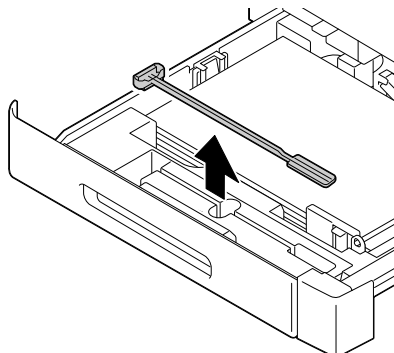

- 4 Close the tray 2.
- 5 Open the machine's front cover.

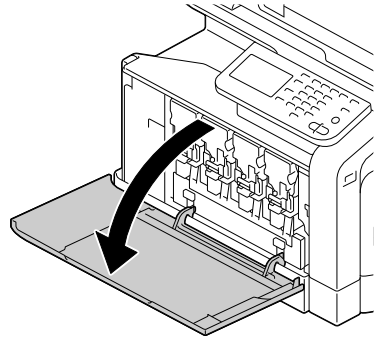

- 6 Remove the waste toner bottle and the toner cartridge and imaging unit for the color of laser lens to be cleaned.



*For details on removing the toner cartridge, imaging unit or waste toner bottle, refer to "Replacing a Toner Cartridge" on page 11-4 or "Replacing a Imaging Unit" on page 11-9.*



*Do not tilt removed toner cartridge, otherwise toner may spill.*



*Do not tilt removed waste toner box, otherwise waste toner may spill.*

- 7 Attach the cover to the removed imaging unit.

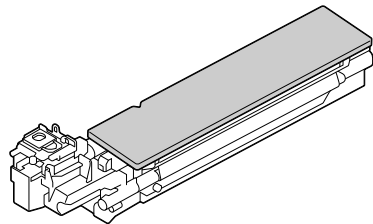
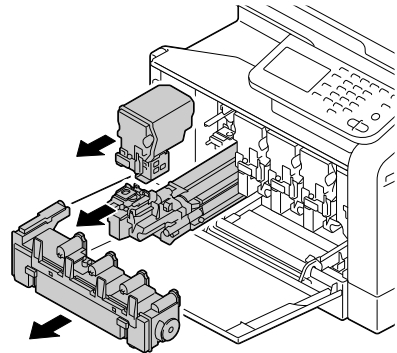

- 8** Insert the laser lens cleaning tool into the imaging unit opening, pull it out, and then repeat this back and forth movement 2 or 3 times.

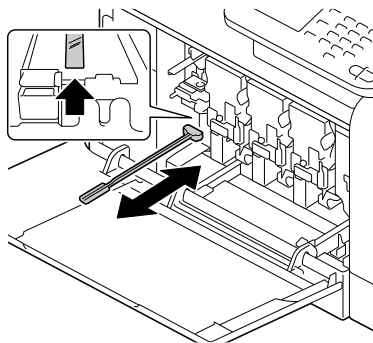

- 9** Install the removed toner cartridge, imaging unit and waste toner bottle.



*For details on installing the toner cartridge, imaging unit or waste toner bottle, refer to "Replacing a Toner Cartridge" on page 11-4 or "Replacing a Imaging Unit" on page 11-9.*

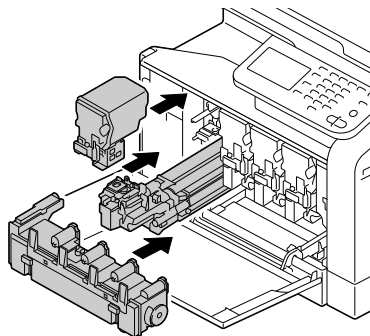

- 10** Close the front cover.

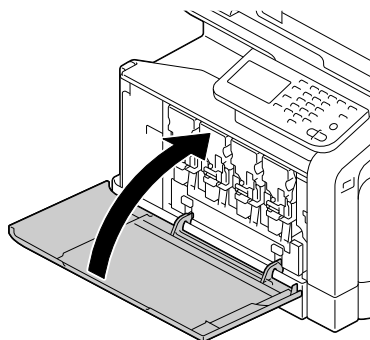

- 11** Pull out the tray 2.



- 12** Return the laser lens cleaning tool to its holder on the inside of the tray 2.

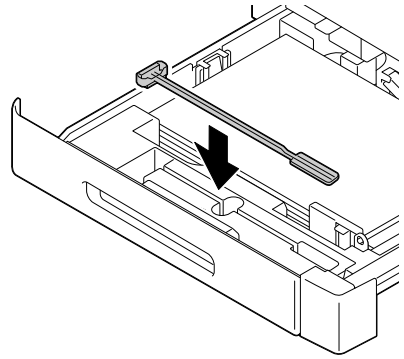

- 13** Close the cover.

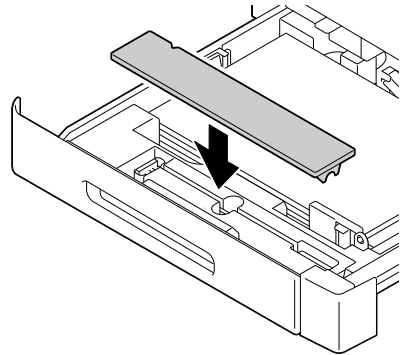

- 14** Close the tray 2.

- 15** Clean between each of the laser lenses in the same way.



*The laser lens cleaning tool is included with the machine.  
Safely store the laser lens cleaning tool so that it will not be lost.*



*Troubleshooting* **13**



# Introduction

This chapter provides information to aid you in resolving machine problems you may encounter, or at least guide you to the proper sources for help.

Printing the configuration page	page 13-2
Unlocking the Scanner	page 13-3
Preventing media misfeeds	page 13-4
Understanding the media path	page 13-5
Clearing media misfeeds	page 13-6
Solving problems with media misfeeds	page 13-23
Solving other problems	page 13-26
Solving problems with printing quality	page 13-31
Status, error, and service messages	page 13-38

## Printing a configuration page

- 1 Press the [Utility/Counter] key.
- 2 Press [User Settings].
- 3 Press [Print Settings].
- 4 Press [Print Reports].
- 5 Press [Configuration Page].
- 6 Press [Print].
- 7 Press [OK].

# Unlocking the Scanner

1 Lift open the ADF cover.

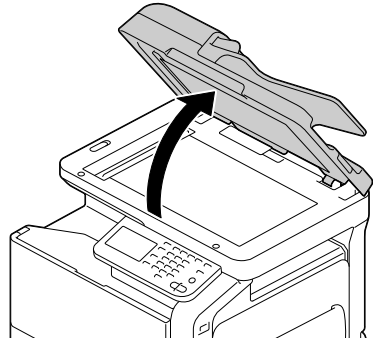

2 Move the scanner lock lever to .

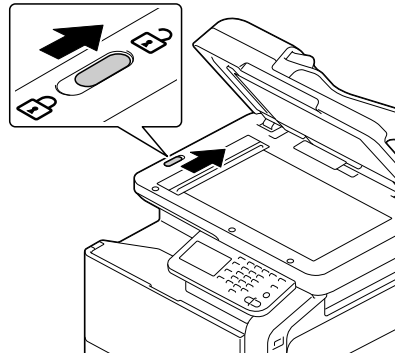

3 Close the ADF cover.

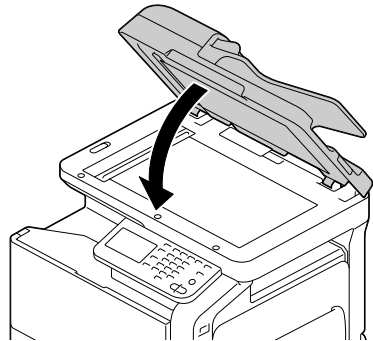

4 Turn off the machine, and then turn it on again.

# Preventing Media Misfeeds

<b>Make sure that...</b>
Media matches the machine specifications.
Media is flat, especially on the leading edge.
The machine is on a hard, flat, level surface.
You store media in a dry location away from moisture and humidity.
You always adjust the media guides in the tray <i>after</i> inserting the media ( <i>a guide that is not properly adjusted can cause poor print quality, media mis-feeds, and machine damage</i> ).
You load the media printing-side up in the tray ( <i>many manufacturers place an arrow on the end of the wrapper to indicate the printing side</i> ).

<b>Avoid...</b>
Media that is folded, wrinkled, or excessively curled.
Double feeding ( <i>remove the media and fan the sheets—they may be sticking together</i> ).
Loading more than one type/size/weight of media in a tray at the same time.
Overfilling the trays.
Allowing the output tray to overfill ( <i>the output tray has a 250-sheet capacity—misfeeding may occur if you allow more than 250 sheets of media to accumulate at one time</i> ).

# Understanding the Media Path

Understanding media path will help you locate media misfeeds

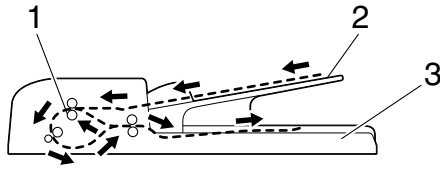

- 1 ADF media feed rollers
- 2 Document feed tray
- 3 Document output tray

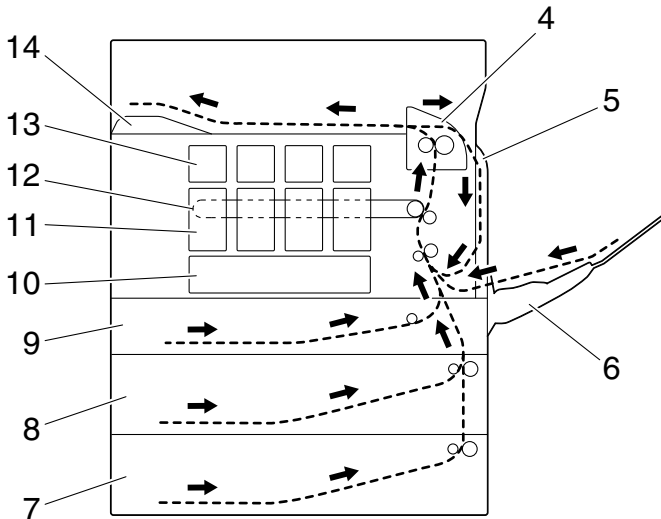

- 4 Fuser unit
- 5 Duplex
- 6 Tray 1 (Manual feed tray)
- 7 Tray 4 (optional lower feeder unit)
- 8 Tray 3 (optional lower feeder unit)
- 9 Tray 2
- 10 Print head unit
- 11 Imaging unit
- 12 Transfer belt unit
- 13 Toner cartridge
- 14 Output tray

# Clearing Media Misfeeds

To avoid damage, always remove misfed media gently, without tearing it. Any piece of media left in the machine, whether large or small, can obstruct the media path and cause further misfeeds. Do not reload media that has misfed.

## Note

The image is not fixed on the media before the fusing process. If you touch the printed surface, the toner may stick to your hands, so be careful not to touch the printed face when removing the misfed media. Make sure not to spill any toner inside the machine.



## CAUTION

Unfused toner can dirty your hands, clothes, or anything else it gets on. If you accidentally get toner on your clothes, lightly dust them off as best as you can. If some toner remains on your clothes, use cool, not hot water, to rinse the toner off. If toner gets on your skin, wash it off with cool water and a mild soap.



## CAUTION

If you get toner in your eyes, wash it out immediately with cool water and consult a doctor.

If, after clearing the media misfeed, the misfeed message in the control panel window persists, open and close the engine cover. This should clear the misfeed message.

## Media misfeed indications

If a misfeed occurs during printing, the message “Misfeed detected” appears and the location of the misfeed is indicated in the screen.

Media misfeed locations	Page reference
Media misfeed in Tray 2	page 13-7
Media misfeed in Tray 3/Tray 4	page 13-11
Media misfeed in the ADF	page 13-13
Media misfeed in the duplex unit	page 13-15
Media misfeed in the fuser unit	page 13-16
Media misfeed in Tray 1 (manual feed tray)	page 13-20



## Clearing a Media Misfeed in Tray 2

- 1 Pull the lever, and then open the right door.



*Before opening the right door, fold up Tray 1.*

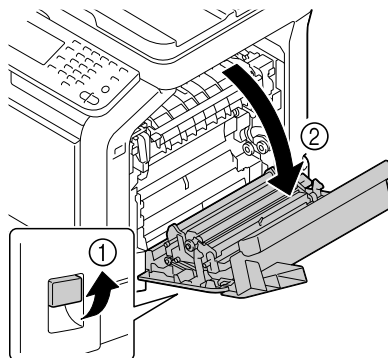

- 2 Carefully pull out the misfed media.

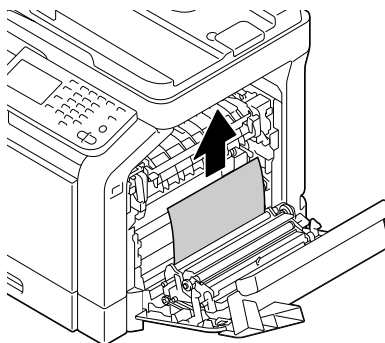



## CAUTION

The area around the fuser unit is extremely hot. Touching anything other than the indicated levers may result in burns. If you get burned, immediately cool the skin under cold water, and then seek professional medical attention.

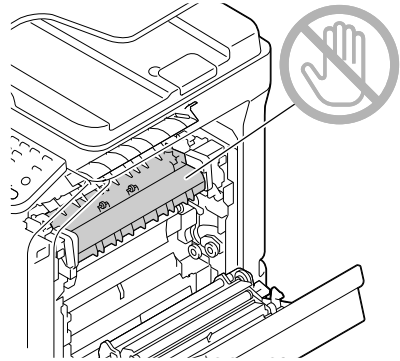

## Note

Decreased print quality may result if the surface of the image transfer belt or the transfer roller is touched.

Be careful not to touch the surface of the image transfer belt or transfer roller.

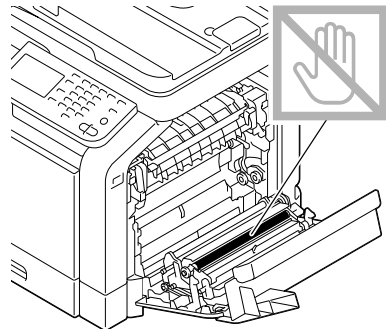
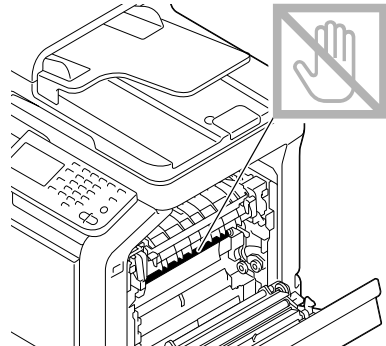

- 3** Close the right side door.

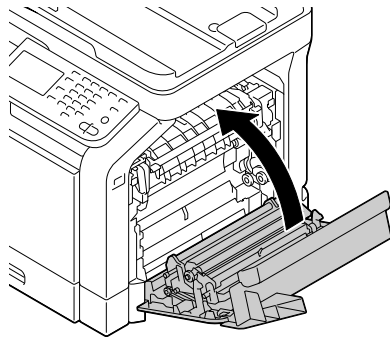

- 4** Pull out Tray 2, and then remove all media from the tray.

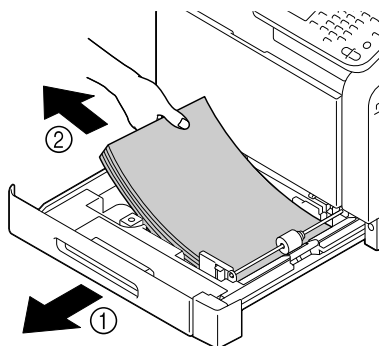

- 5** Fan the media you removed and then align it well.

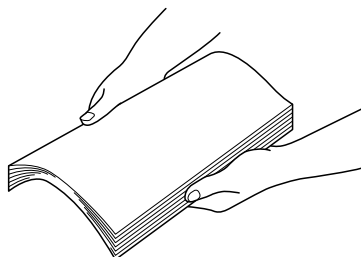

**6** Load the media face up in Tray 2.

 *Make sure that the media is flat.*

 *Do not load paper above the ▼ mark.*

 *Slide the media guides against the edges of the paper.*

**7** Close Tray 2.

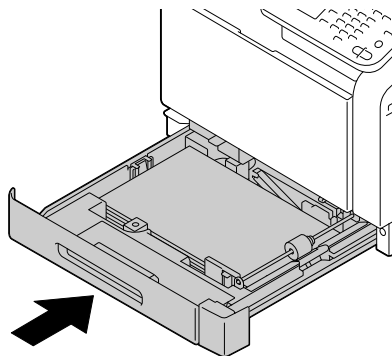

## Clearing a Media Misfeed in Tray 3/4

- 1 Open the right side cover of Tray 3 or Tray 4.



*Before opening the right side cover of Tray 3 or Tray 4, fold up Tray 1.*

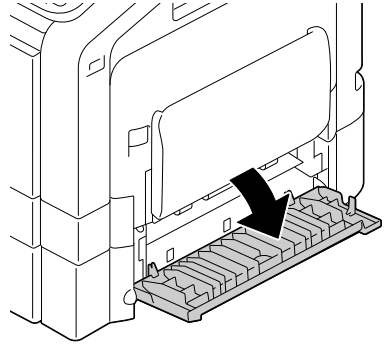

- 2 Carefully pull out the misfed media.

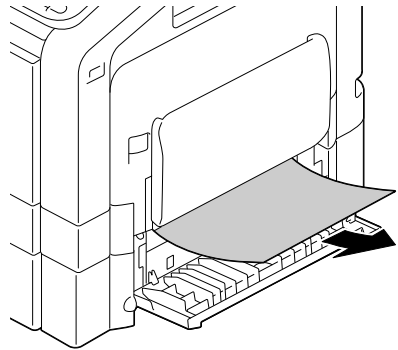

- 3 Close the right side cover of Tray 3 or Tray 4.

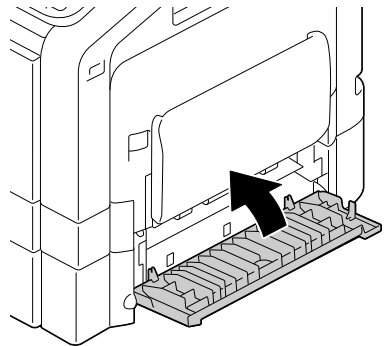

- 4** Pull out Tray 3 or Tray 4, and then remove all paper from the tray.

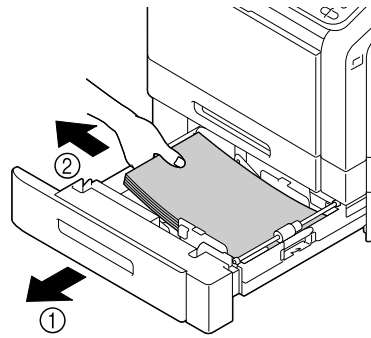

- 5** Fan the paper you removed and then align it well.

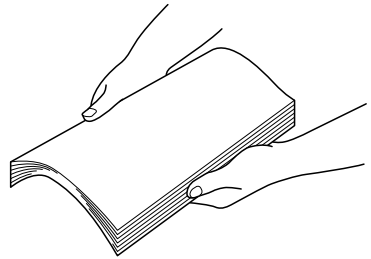

- 6** Load the paper face up in Tray 3 or Tray 4.



*Make sure that the paper is flat.*



*Do not load paper above the ▼ mark.*



*Slide the media guides against the edges of the paper.*

- 7** Close Tray 3 or Tray 4.

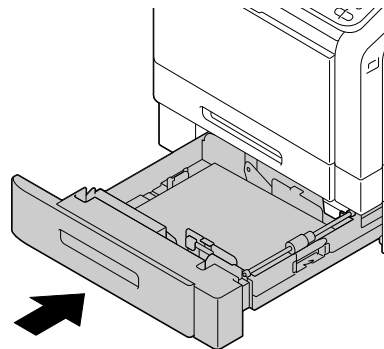

## Clearing a Media Misfeed from the ADF

- 1 Open the ADF feed cover.

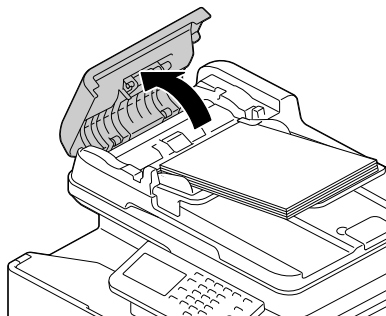

- 2 Remove the document from the ADF document feed tray.

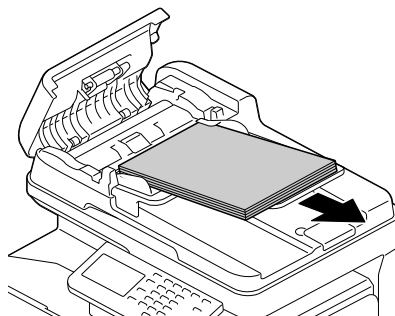

- 3 Lift to open the ADF cover.

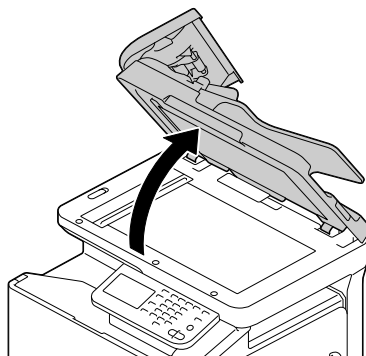

**4** Remove any misfed media.

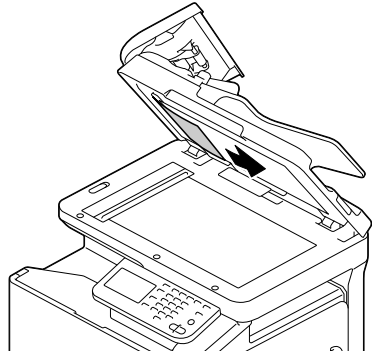

**5** Close the ADF cover.

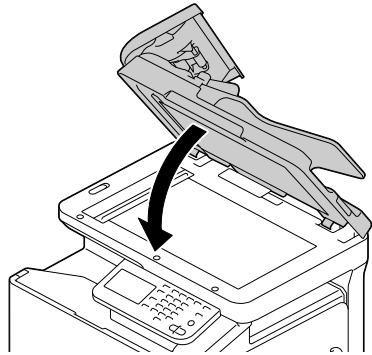

**6** Close the ADF feed cover.

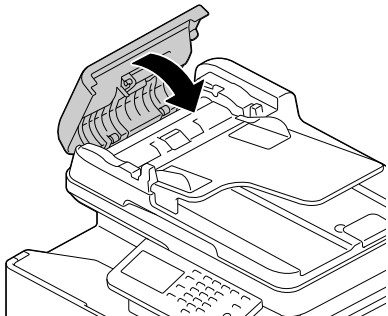



## Clearing a Media Misfeed from the Duplex

- 1 Pull the lever, and then open the right door.



*Before opening the right door, fold up Tray 1.*

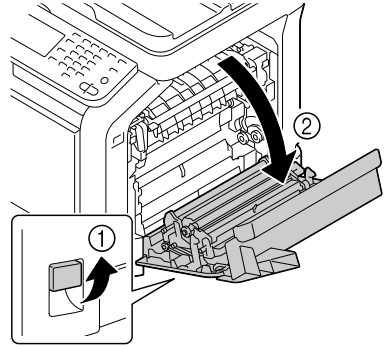

- 2 Carefully pull out the misfed media.

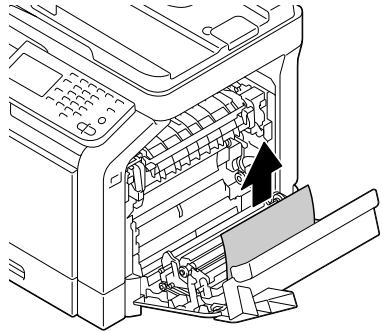

- 3 Close the right door.

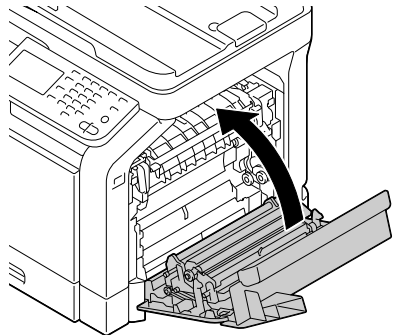

## Clearing a Media Misfeed from the Fuser Unit

- 1 Pull the lever, and then open the right door.



*Before opening the right door, fold up Tray 1.*

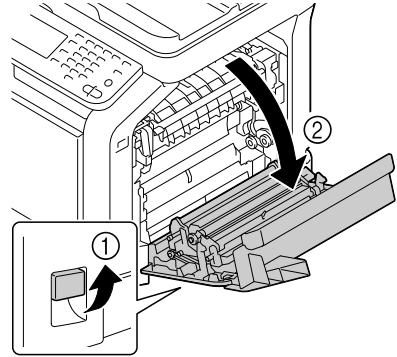

- 2 Lift up the 2 levers.

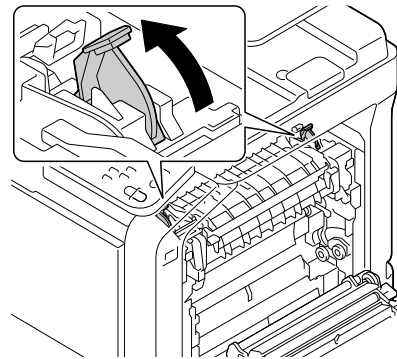

- 3 Open the fuser unit cover.

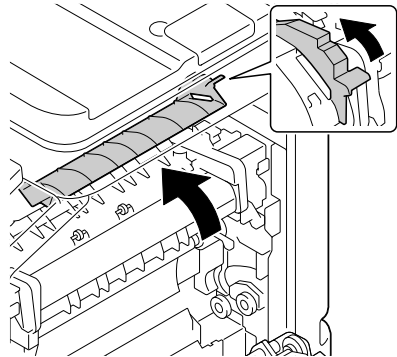

- 4** Carefully pull out the misfed media.

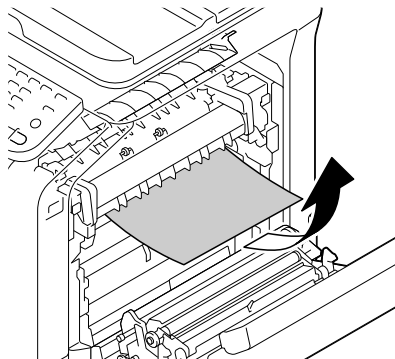

*If the misfed media cannot be removed by pulling it down, pull it from the top of the fuser unit.*

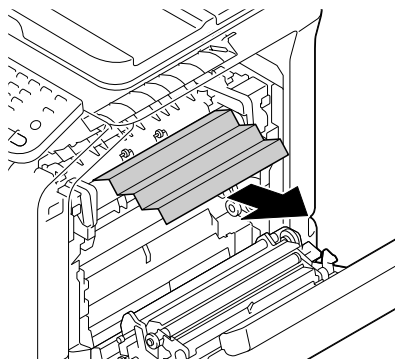
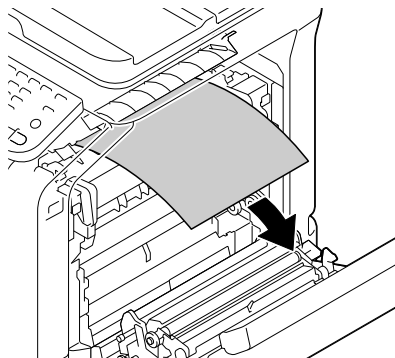



## CAUTION

The area around the fuser unit is extremely hot. Touching anything other than the indicated levers may result in burns. If you get burned, immediately cool the skin under cold water, and then seek professional medical attention.

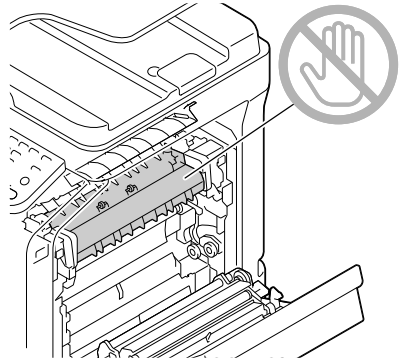

## Note

Decreased print quality may result if the surface of the image transfer belt or the transfer roller is touched.

Be careful not to touch the surface of the image transfer belt or transfer roller.

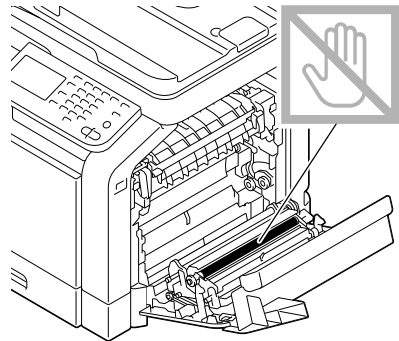
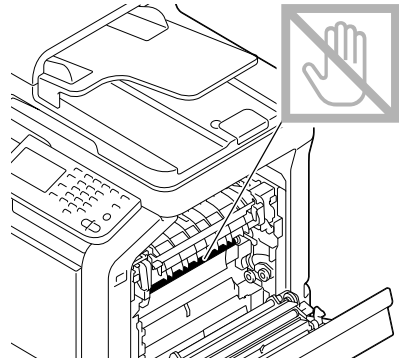

**5** Close the fuser unit cover.

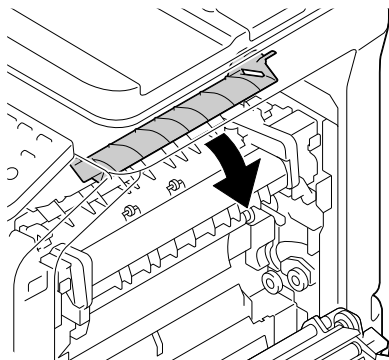

**6** Push down the 2 levers.

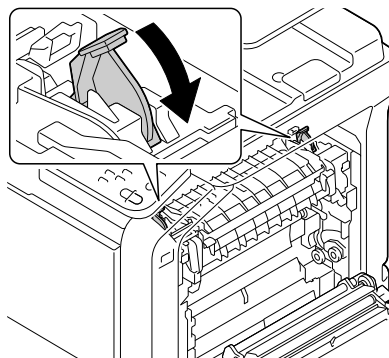

**7** Close the right door.

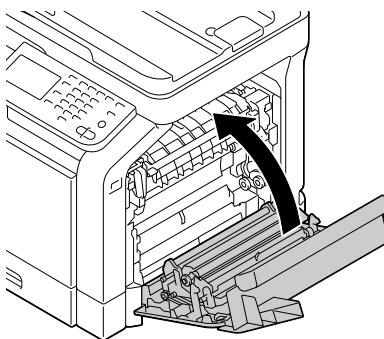

## Clearing a Media Misfeed from Tray 1 (Manual Feed Tray) and Transfer Roller

- 1 Pull the lever, and then open the right door.



*Before opening the right door, fold up Tray 1.*

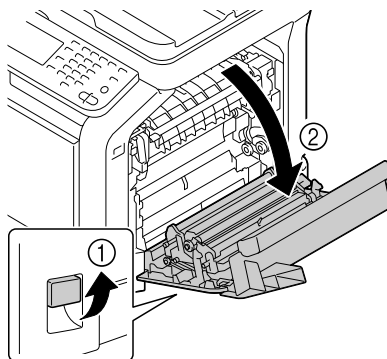

- 2 Carefully pull out the misfed media.

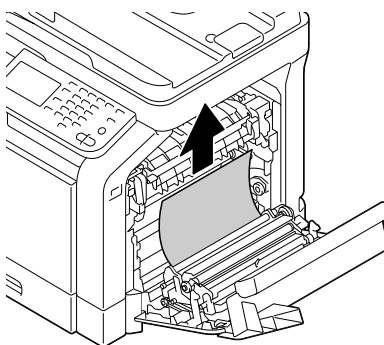



## CAUTION

The area around the fuser unit is extremely hot. Touching anything other than the indicated levers may result in burns. If you get burned, immediately cool the skin under cold water, and then seek professional medical attention.

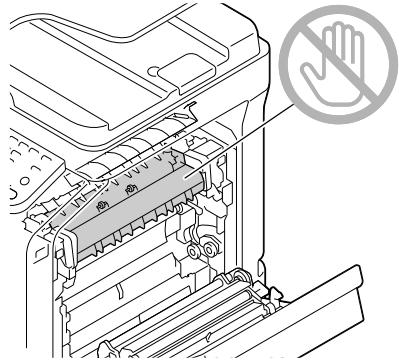

## Note

Decreased print quality may result if the surface of the image transfer belt or the transfer roller is touched.

Be careful not to touch the surface of the image transfer belt or transfer roller.

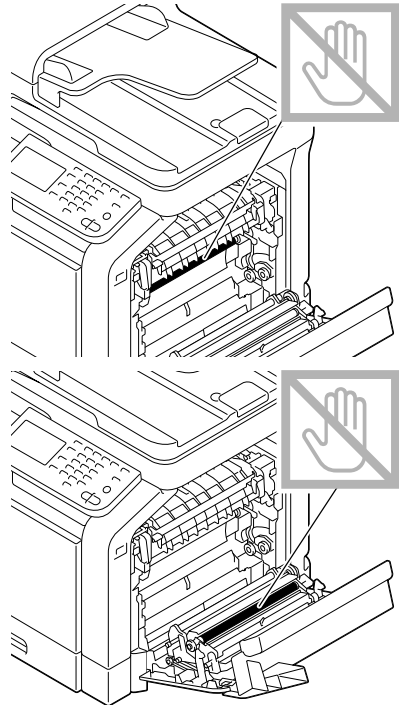

**3** Close the right door.

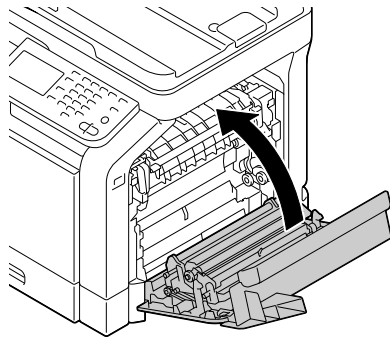



# Solving Problems with Media Misfeeds



*Frequent misfeeds in any area indicate that area should be checked, repaired, or cleaned. Repeated misfeeds may also happen if you're using unsupported print media or original media.*

Symptom	Cause	Solution
Several sheets go through the machine together.	The front edges of the media are not even.	Remove the media and even up the front edges, then reload it.
	The media is moist from humidity.	Remove the moist media and replace it with new, dry media.
Media misfeed message stays on.	Front cover needs to be opened and closed again to reset the machine.	Open and close the front cover again.
	Some media remains misfed in the machine.	Check the media path again to make sure that you have removed all of the misfed media.
Duplex misfeeds.	Unsupported media (wrong size, thickness, type, etc.) is being used.	Use approved media. See "Special Paper" on page 4-11.
		Plain paper, recycled paper, special paper, Thick 1 and Thick 2 can be autoduplexed if the media type is set properly in the driver. See "Specifications" on page 4-2.
		Make sure that you have not mixed media types in the tray.
		Do not duplex, envelopes, labels, letter head, postcards, glossy media, or single side only paper.
	Media is still being misfed.	Check the media path inside the duplex again to make sure that you have removed all of the misfed media.

<b>Symptom</b>	<b>Cause</b>	<b>Solution</b>
Media is misfed in the ADF.	The loaded document does not meet the specifications.	Load the correct document. For details on the documents that can be loaded, refer to “Documents that can be loaded into the ADF” on page 4-34.
	The loaded document exceeds the maximum capacity.	Load the document so that it does not exceed the maximum capacity. For details on the documents that can be loaded, refer to “Documents that can be loaded into the ADF” on page 4-34.
	The document guides were not slid against the edges of the document.	Slide the document guides against the edges of the document. For details on loading the document, refer to “Loading a document into the ADF” on page 4-37.
Media is misfeeding.	The media is not correctly positioned in the tray.	Remove the misfed media and reposition the media properly in the tray.
	The number of sheets in the tray exceeds the maximum allowed.	Remove the excess media and reload the correct number of sheets in the tray.
	The media guides are not correctly adjusted to the media size.	Adjust the media guides in the Tray 1 to match the size of the media.
	Warped or wrinkled media is loaded in the tray.	Remove the media, smooth it out, and reload it. If it still misfeeds, do not use that media.
	The media is moist from humidity.	Remove the moist media and replace it with new, dry media.
	Envelopes are loaded in Tray 2, 3, 4.	Envelope must be loaded in Tray 1 only.
	Labels, letterhead, postcards, thick stock, or glossy are loaded in Tray 3, 4.	Labels, letterhead, postcards, thick stock, or glossy must be loaded in Tray 1 or 2.
	Custom-sized media is loaded in Tray 3, 4.	Custom-sized media can be loaded in Tray 1 or 2. See “Print Media” on page 4-2.

Symptom	Cause	Solution
	The recommended label sheet is facing the wrong way in Tray 1.	Load the label sheets according to the manufacturer's instructions.
	Envelopes are facing the wrong way in Tray 1.	Load the envelopes in Tray 1 with the flaps facing up.
		If the flaps are on the long edge, load the envelopes with the flap edge toward the machine and the flap side facing up.
	Unsupported media (wrong size, thickness, type, etc.) is being used.	Use approved media. See "Specifications" on page 4-2.
The media feed roller is dirty.	Clean the media feed roller. For more details, refer to "Media Rollers" on page 12-5.	

# Solving Other Problems

Symptom	Cause	Solution
Machine power is not on.	The power cord is not correctly plugged into the outlet.	Turn off the machine, confirm that the power cord is correctly plugged into the outlet, and then turn on the machine.
	Something is wrong with the outlet connected to the machine.	Plug another electrical appliance into the outlet and see whether it operates properly.
	The power switch is not correctly turned on (I position).	Turn the power switch off (O position), then turn it back to the on (I position).
	The machine is connected to an outlet with a voltage or frequency that does not match the machine specifications.	Use a power source with the specifications listed in appendix A, "Technical Specifications."
The control panel displays [Toner is low.] much sooner than expected.	One of the toner cartridges may be defective.	Remove the toner cartridges and check for damage. If it is damaged, replace it.
	Printed with heavy toner coverage.	See specifications in Appendix A.
Cannot print the machine status list.	The tray is empty.	Check that at least Tray 1 is loaded with media, in place, and secure.
	There is a media misfeed.	Clear the media misfeed.

Symptom	Cause	Solution
Printing from a USB memory device is not possible.	[External Memory Print] is set to [Disable].	Press the [Utility/Counter] key, and then set [Admin Settings] - [External Memory Print] to [Enable].
	The file format (file extension) is not one that can be printed.	Only files with the format (extension) for JPEG, TIFF, XPS or PDF can be printed.
		Press [USB/HDD], and then, with [External Memory] - [File Type], select the type of files to be displayed.
A public user is not specified for user authentication.	Contact the administrator of this unit.	
Printing takes too much time.	The machine is set to a slow printing mode (for example, thick stock).	It takes more time to print with special media. When using regular paper, make sure that the media type is set properly in the driver.
	The machine is set to power saving mode.	It takes time for printing to start in power saving mode.
	The job is very complex.	Wait. No action needed.
	A toner cartridge for a different region or an unapproved toner cartridge is installed ([Incorrect toner cartridge] is displayed in the message window).	Install a correct toner cartridge approved for your specific machine.
	If an error has been detected during printing job transmission in the Copy mode, it takes a while to process the error and resume the printing operation.	Wait. No action needed.
Blank pages are printed.	One or more of the toner cartridges are defective or empty.	Check the toner cartridges. The image will not print correctly or not at all, if the cartridges are empty.
	The wrong media is being used.	Check that the media type.

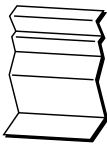

Symptom	Cause	Solution
Not all pages print.	A different user accidentally canceled the job.	Try printing the remaining pages.
	The tray is empty.	Check that the tray is loaded with media, in place, and secure.
	A document is printed with an overlay file which has been created by an unsuitable printer driver.	Print the overlay file using a suitable printer driver.
Machine resets or turns off frequently.	The power cord is not correctly plugged into the outlet.	Turn off the machine, confirm that the power cord is correctly plugged into the outlet, and then turn on the machine.
	A system error occurred.	Contact Technical Support with the error information.
You are experiencing duplex problems.	Media or settings are not correct.	Make sure that you are using correct media. <ul style="list-style-type: none"> <li>■ See “Specifications” on page 4-2.</li> <li>■ Do not duplex custom-sized media, envelopes, labels, postcards, letterhead, or glossy media.</li> <li>■ Make sure that you have not mixed media types in the tray.</li> </ul>
		In the Windows printer driver ([Layout]/[Print Type]), choose [2-Sided].”
		Set duplex (Double-Sided) copying. For details on setting duplex (Double-Sided) copying, refer to “About Duplex Printing” on page 4-30.
		For N-up on duplexed pages, choose Collate only in the printer driver’s [Basic] Tab. Do not set collation in the application.
With N-up on multiple copies, the output is incorrect.	Both the printer driver and the application have been set for collation.	For N-up on multiple copies, choose Collate only in the printer driver’s Basic Tab. Do not set collation in the application.



<b>Symptom</b>	<b>Cause</b>	<b>Solution</b>
Booklet Left and Right Binding output is incorrect.	Both the printer driver and the application have been set for collation.	For Booklet Left Binding and Booklet Right Binding, choose Collate only in the printer driver's Basic Tab. Do not set collation in the application.
You hear unusual noises.	The machine is not level.	Place the machine on a flat, hard, level surface.
	The tray is not installed correctly.	Remove the tray that you are printing from and reinsert it completely into the machine.
	There is a foreign object stuck inside the machine.	Turn off the machine and remove the object. If you cannot remove it, contact Technical Support.
Some areas of the scanned image are missing.	Acrobat 8 (Macintosh version) is used for scanning the image.	With the Acrobat Scan setting, turn off the OCR and Filtering functions.
The web-based utility cannot be accessed.	The Web Connection Administrator's password is incorrect.	The Web Connection Administrator password has a 0-character minimum and an 16-character maximum. For details of the Web Connection administrator password, refer to the [Reference Guide] on the Documentation CD/DVD.
Media is wrinkled. 	The media is moist from humidity or having water spilled on it.	Remove the moist media and replace it with new, dry media.
	The media feed roller or fuser unit is defective.	Check them for damage. If necessary, contact Technical Support with the error information.
	Unsupported media (wrong size, thickness, type, etc.) is being used.	Use approved media. See "Specifications" on page 4-2.

<b>Symptom</b>	<b>Cause</b>	<b>Solution</b>
Data was sent to the machine, but it doesn't print.	An error message is displayed in the message window.	Handle according to the message displayed.
	A job may be cancelled if user authentication setting is specified.	Click the User Authentication button in the printer driver, and then type in the necessary information before printing.
The hard disk was automatically formatted.	The hard disk was full.	When the control panel displays [HDD is low on disk space.], delete print jobs and resources (fonts, forms, etc.) which were saved on the hard disk using Download Manager or Web Connection.
A network connection cannot be established with an IPv4 address.	Duplicate detection of the IPv6 address failed.	Set [Ethernet]/[TCP/IP]/[IPv6]/[Enable] in [Admin Settings] menu to [No].





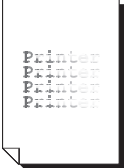

# Solving Problems with Printing Quality

Symptom	Cause	Solution
Nothing is printed, or there are blank spots on the printed page. 	One or more of the toner cartridges may be defective.	Remove the toner cartridges and check if any is damaged.
	One or more of the imaging units may be defective.	Remove the imaging units and check for damage. If it is damaged, replace it.
	The media is moist from humidity.	Adjust the humidity for media storage. Remove the moist media and replace it with new, dry media.
	The media set in the printer driver mismatches the media loaded in the machine.	Load the correct media in the machine.
	Several sheets are being fed at the same time.	Remove the media from the tray and check for static electricity. Fan plain paper or other media, and replace it in the tray.
Entire sheet is printed in black or color. 	One or more of the toner cartridges may be defective.	Remove the toner cartridges and check for damage. If it is damaged, replace it.
	One or more of the imaging units may be defective.	Remove the imaging units and check for damage. If it is damaged, replace it.

Symptom	Cause	Solution
Image is too light; there is low image density. 	Laser lens is dirty.	Clean the laser lens.
	The copy density is set too light.	Select a darker copy density.
	The media is moist from humidity.	Remove the moist media and replace with new, dry media.
	There is not much toner left in the cartridge.	Replace the toner cartridge.
	One or more of the toner cartridges may be defective.	Remove the toner cartridges and check for damage. If it is damaged, replace it.
	Media type is set incorrectly.	When printing envelopes, labels, letter head, postcards, thick stock, glossy media, single side only paper or special paper, specify the appropriate media type in the printer driver.
Image is too dark. 	The copy density is set too dark.	Select a lighter copy density.
	The document was not pressed close enough against the original glass.	Position the document so that it is pressed close enough against the original glass. For details on positioning the document on the original glass, refer to "Placing a document on the original glass" on page 4-36.
	One or more of the toner cartridges may be defective.	Remove the toner cartridges and check for damage. If it is damaged, replace it.
	One or more of the imaging units may be defective.	Remove the imaging units and check for damage. If it is damaged, replace it.

Symptom	Cause	Solution
<p>Image is blurred; background is lightly stained; there is insufficient gloss of the printed image.</p> 	One or more of the toner cartridges may be defective.	Remove the toner cartridges and check for damage. If it is damaged, replace it.
	One or more of the imaging units may be defective.	Remove the imaging units and check for damage. If it is damaged, replace it.
	The original glass is dirty.	Clean the original glass. For details, refer to “Cleaning the machine” on page 12-4.
	The original cover pad is dirty.	Clean the original cover pad. For details, refer to “Cleaning the machine” on page 12-4.
<p>The print or color density is uneven.</p> 	One or more of the toner cartridges may be defective or low.	Remove the toner cartridges and check for damage. If it is damaged, replace it.
	One or more of the imaging units is defective.	Remove the imaging units and check for damage. If it is damaged, replace it.
	The machine is not level.	Place the machine on a flat, hard, level surface.

Symptom	Cause	Solution
<p data-bbox="194 122 328 236">Irregular print or mottled image appears.</p> 	<p data-bbox="346 122 576 177">The media is moist from humidity.</p>	<p data-bbox="590 122 994 177">Adjust the humidity in the media storage area.</p> <p data-bbox="590 197 999 252">Remove the moist media and replace it with new, dry media.</p>
	<p data-bbox="346 268 576 379">Unsupported media (wrong size, thickness, type, etc.) is being used.</p>	<p data-bbox="590 268 988 322">Use approved media. See “Specifications” on page 4-2.</p>
	<p data-bbox="346 395 576 481">One or more of the toner cartridges may be defective.</p>	<p data-bbox="590 395 964 481">Remove the toner cartridges and check for damage. If it is damaged, replace it.</p>
	<p data-bbox="346 494 576 580">One or more of the imaging units is defective.</p>	<p data-bbox="590 494 999 549">Remove the imaging units and check for damage. If it is damaged, replace it.</p>
<p data-bbox="194 596 328 794">There is insufficient fusing or the image comes off when rubbed.</p> 	<p data-bbox="346 596 576 651">The media is moist from humidity.</p>	<p data-bbox="590 596 999 651">Remove the moist media and replace it with new, dry media.</p>
	<p data-bbox="346 662 576 774">Unsupported media (wrong size, thickness, type, etc.) is being used.</p>	<p data-bbox="590 662 988 716">Use approved media. See “Specifications” on page 4-2.</p>
	<p data-bbox="346 794 576 849">Media type is set incorrectly.</p>	<p data-bbox="590 794 999 935">When printing envelopes, labels, letter head, postcards, thick stock, single side only paper or special paper, specify the appropriate media type in the printer driver.</p>

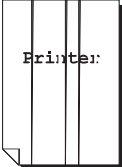
Symptom	Cause	Solution
<p>There are toner smudges or residual images.</p> 	One or more of the toner cartridges are defective or installed incorrectly.	Remove the toner cartridges and check for damage. If it is damaged, replace it.
<p>There are toner smudges on the back side of the page (whether or not it has been duplexed).</p> 	The media transfer roller is dirty.	<p>Clean the media transfer roller.</p> <p>If you think the transfer roller should be replaced, contact Technical Support with the error information.</p>
	The media path is dirty with toner.	Print several blank sheets and the excess toner should disappear.
	One or more of the toner cartridges are defective.	Remove the toner cartridges and check for damage. If it is damaged, replace it.
	One or more of the imaging units is defective.	Remove the imaging units and check for damage. If it is damaged, replace it.
<p>Abnormal areas (white, black, or color) appear in a regular pattern.</p> 	The laser lens is dirty.	Clean the laser lens.
	A toner cartridge may be defective.	Remove the toner cartridges with the color causing the abnormal image. Replace it with a new toner cartridge.
	One or more of the imaging units is defective.	Remove the imaging units and check for damage. If it is damaged, replace it.

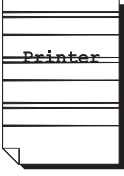
Symptom	Cause	Solution
Image defects. 	The laser lens is dirty.	Clean the laser lens.
	A toner cartridge may be leaking.	Remove the toner cartridges and check for damage. If it is damaged, replace it.
	A toner cartridge may be defective.	Remove the toner cartridge with the color causing the abnormal image.  Replace it with a new toner cartridge.
	One or more of the imaging units may be defective.	Remove the imaging units and check for damage. If it is damaged, replace it.
Lateral lines or bands appear on image. 	The machine is not level.	Place the machine on a flat, hard, level surface.
	The media path is dirty with toner.	Print several sheets and the excess toner should disappear.
	One or more of the toner cartridges may be defective.	Remove the toner cartridges and check for damage. If it is damaged, replace it.
	One or more of the imaging units is defective.	Remove the imaging units and check for damage. If it is damaged, replace it.
Colors look drastically wrong.	One or more of the toner cartridges may be defective.	Remove the toner cartridges and verify that the toner is distributed evenly on each cartridge roller, and reinstall the toner cartridges.

Symptom	Cause	Solution
Colors are not registering properly; colors are mixed or have page-to-page variation.	Gradations are not adjusted correctly.	Set [Print Settings]/[Quality Settings]/[Gradation Adjustment]/[Tone Calibration] in the [Admin Settings] menu to [ON], and then perform the AIDC color calibration. For details, refer to “[Print Settings]” on page 3-49.
	The front cover is opened during the calibration.	
	One or more of the toner cartridges may be defective.	Remove the toner cartridges and check for damage. If it is damaged, replace it.
	The media is moist from humidity.	Remove the moist media and replace it with new, dry media.
The color has a poor reproduction or has poor color density.  	One or more of the imaging units may be defective.	Remove the imaging units and check for damage. If it is damaged, replace it.

If the problem is not resolved, even after all of the above have been performed, contact Technical Support with the error information.

# Status, error and service messages

Various status, error and service messages appear in the touch panel of the control panel. They provide information about the machine and help you locate problems that may have occurred. Check the message that appears, and then perform the necessary steps.

## Status messages

Message	Cause	Solution
[Initializing]	The machine was turned on.	No action is required.
[Restarting]	The machine is being restarted.	
[Enter Power Save mode]	The machine is entering normal operation mode from Power Save mode.	
[Calibrating]	The image is being adjusted.	
[Warming up]	The machine is warming up or AIDC is being performed.	
[Check setting. Tray x]	The paper specified from the touch panel was loaded in the paper tray.	
[TWAIN/WSD connecting]	Computer scanning is being performed with TWAIN or a Web Service.	



## Error messages

### Warning messages

Message	Cause	Solution
<b>[Unable to collate.]</b> [Prints one set only.]	There is not enough space available on the hard disk for collated printing.	After one copy is printed, the error is canceled.
<b>[HDD is low on disk space.]</b> [Delete unneeded file.]	There is too little space available on the hard disk.	Delete downloaded fonts. Otherwise, initialize the hard disk.
<b>[Replace imaging unit.]</b> [Replace imaging unit.] [x]	The time to replace the imaging unit has been reached.	Replace the indicated imaging unit.
<b>[Replace toner (x)]</b> [Toner empty. Replace toner and close front door. x]	The time to replace the toner cartridge has been reached.	Replace the indicated toner cartridge.
<b>[Replace image transfer belt.]</b> [Replace transfer belt unit.]	The time to replace the transfer belt unit has been reached.	Replace the transfer belt unit.  After replacing the transfer belt unit, reset its counter. For details, refer to “[Maintenance Menu]” on page 3-63.
<b>[Replace fusing unit.]</b> [Replace fusing unit.]	The time to replace the fuser unit has been reached.	Replace the fuser unit.  After replacing the fuser unit, reset its counter. For details, refer to “[Maintenance Menu]” on page 3-63.
<b>[Replace waste toner box.]</b> [Prepare new waste toner box.]	The time to replace the waste toner bottle is near.	Prepare the new waste toner bottle.

<b>Message</b>	<b>Cause</b>	<b>Solution</b>
<p><b>[Toner is low.]</b></p> <p>[Prepare new toner cartridge.]</p> <p>[x]</p>	<p>The time to replace the toner cartridge is near.</p>	<p>Prepare the new toner cartridge.</p>
<p><b>[Replace imaging unit soon.]</b></p> <p>[Prepare new imaging unit.]</p> <p>[x]</p>	<p>The time to replace the imaging unit is near.</p>	<p>Prepare the new imaging unit.</p>
<p><b>[Replenish paper]</b></p> <p>[Replenish paper.]</p> <p>[Trayx]</p>	<p>There is no paper in the paper tray.</p> <p>Appears when [Paper Empty] ([Admin Settings]) is set to [ON]. For details, refer to "[Paper Empty]" on page 3-78.</p>	<p>Load paper into the paper tray.</p>
<p><b>[Incorrect toner cartridge]</b></p> <p>[Install proper toner cartridge.]</p> <p>[x]</p>	<p>A toner cartridge incompatible with the machine has been installed.</p>	<p>Replace the indicated toner cartridge with a correct one.</p>
<p><b>[Incorrect Imaging Unit]</b></p> <p>[Install proper imaging unit.]</p> <p>[x]</p>	<p>An imaging unit incompatible with the machine has been installed.</p>	<p>Replace the indicated imaging unit with a correct one.</p>
<p><b>[Replace transfer roller unit.]</b></p> <p>[Replace transfer roller unit.]</p>	<p>The time to replace the transfer roller has been reached.</p>	<p>Replace the transfer roller.</p> <p>After replacing the transfer roller, reset its counter. For details, refer to "[Maintenance Menu]" on page 3-63.</p>
<p><b>[USB hub is not supported.]</b></p> <p>[Disconnect USB hub.]</p>	<p>A USB hub is connected to the USB HOST port.</p>	<p>Disconnect the USB hub from the USB HOST port.</p>

<b>Message</b>	<b>Cause</b>	<b>Solution</b>
<b>[The USB device is invalid.]</b> [Disconnect USB device.]	An incompatible USB device is connected to the USB HOST port.	Disconnect the USB device from the USB HOST port.
<b>[IEEE802.1x Auth. failed]</b> [Please reboot.]	IEEE 802.1X port authentication timed out.	Turn the machine off, then on again.
<b>[IEEE802.1x Authenticating]</b> [Please wait.]	IEEE 802.1X port authentication is being performed.	If authentication is successful, the message is cleared.  If authentication times out, turn the machine off, then on again.

## Operator messages

<b>Message</b>	<b>Cause</b>	<b>Solution</b>
<b>[Configuration of Options Changed]</b> [Configuration of Options Changed] [Power Off and ON.]	An optional lower feeder unit was installed or removed while the machine is on.	Turn the machine off, wait a few seconds, and then it on again.
<b>[Cover Open]</b> [Cover is open.] [Close all covers properly.]	The cover is open.	Close the indicated cover.
<b>[Misfeed Detected]</b> [Misfeed was detected.] [Remove the paper.]	A media misfeed occurred.	Open the indicated cover, and remove the misfed media.
<b>[Imaging Unit Missing]</b> [Install imaging unit and close all doors.]	No imaging unit is installed. Otherwise, an imaging unit incompatible with the machine has been installed.	Install the correct imaging unit.

<b>Message</b>	<b>Cause</b>	<b>Solution</b>
<b>[Toner Cartridge Missing]</b> [install toner cartridge and close all doors.]	No toner cartridge is installed. Otherwise, a toner cartridge incompatible with the machine has been installed.	Install the correct toner cartridge.
<b>[Waste Toner Box Full]</b> [Replace waste toner box by following the instruction.]	The waste toner bottle is full.	Replace the waste toner bottle.
<b>[Replace Imaging Unit]</b> [Open front door and replace imaging unit by following the instruction.]	The time to replace the imaging unit has been reached.	Replace the appropriate imaging unit.
<b>[Replace Toner (x)]</b> [Replace toner by following the instruction and close front door.]	The time to replace the toner cartridge has been reached.	Replace the appropriate toner cartridge.
<b>[Paper Size Mismatch]</b> [Load xxx in Tray x or cancel job.]	The paper size specified from the touch panel is different from the size of paper loaded in the paper tray.	Load paper of the correct size into the indicated paper tray.  Otherwise, cancel the job.
<b>[Paper Setting for Manual feed]</b> [Load xx xxxx in bypass tray. Touch [Print].]	Tray 1 has been selected for printing.	Press [Print]. Otherwise, cancel the job.
<b>[Replenish paper]</b> [Replenish paper or select other paper tray.]	No other paper tray contains paper matching the specified type and size. (when [Auto Tray Switching] is set to [ON])	Load the specified paper into a paper tray.
<b>[Replenish paper]</b> [Load paper in bypass tray or select other paper tray.]	There is no paper in Tray 1 when printing with Tray 1 selected. (when [Auto Tray Switching] is set to [OFF])	Load paper into Tray 1.

<b>Message</b>	<b>Cause</b>	<b>Solution</b>
<p><b>[Replenish paper]</b></p> <p>[Replenish paper in Tray x or select other paper tray.]</p>	<p>There is no paper in the paper tray selected for printing. (when [Auto Tray Switching] is set to [OFF])</p>	<p>Load paper into the specified paper tray.</p>
<p><b>[Paper Size/Type Mismatch]</b></p> <p>[Load the following paper in tray x.]</p> <p>[Paper : xxxxx xxxxx]</p>	<p>The type and size of the paper loaded into all of the paper trays are different. (when [Auto Tray Switching] is set to [ON])</p>	<p>Load the specified paper into a paper tray.</p>
<p><b>[Output Tray Full]</b></p> <p>[Output tray full. Remove paper from the tray.]</p>	<p>The output tray is full of paper.</p>	<p>Remove the paper from the output tray.</p>
<p><b>[Memory Full]</b></p> <p>[Insufficient memory Cancel the job.]</p>	<p>The print data sent from the computer has caused the memory to become full.</p>	<p>Cancel the job.</p>
<p><b>[Stored Job Error]</b></p> <p>[Stored job specification not correct.]</p> <p>[Tray x]</p>	<p>Tray 3/Tray 4 was specified for printing a stored job when Tray 3/Tray 4 is not installed on the machine.</p> <p>When trying to print a stored job, the installed memory had been changed since the job was stored.</p>	<p>Install Tray 3/Tray 4, or install the memory that had been installed when the job was stored.</p>
<p><b>[Job Registration Limit Over]</b></p> <p>[Registered jobs reached limit.]</p> <p>[Wait for job registration to complete.]</p>	<p>Copy, scan or fax transmission operations were repeated while printing or transmissions could not be performed.</p>	<p>Wait a while. The error is canceled.</p>

<b>Message</b>	<b>Cause</b>	<b>Solution</b>
<p><b>[Check Scanner Lock Lever]</b></p> <p>[Unlock the scanner lock lever.]</p>	The scanner is locked.	<p>Cancel the job.</p> <p>Unlock the scanner.</p> <p>For details, refer to “Unlocking the Scanner” on page 13-3.</p>
<p><b>[Place Original on Glass]</b></p> <p>[Unable to scan from ADF with this original size.]</p>	The selected document size cannot be scanned from the ADF.	Place the document on the original glass if it has a size that cannot be scanned from the ADF.
<p><b>[Place Original on ADF]</b></p> <p>[Place originals on the Document Feeder.]</p>	The document is not loaded into the ADF when scanning a document containing pages of different sizes.	Load the document into ADF.
<p><b>[Matching Paper not Available]</b></p> <p>[Paper of matching size not available.]</p> <p>[xxxxx]</p>	Paper of the same size as the document cannot be selected with the [Auto] Paper setting selected in Copy mode.	Load the paper tray with paper of the same size as the document.
<p><b>[Out of the Range of Auto Zoom]</b></p> <p>[Zoom ratio for paper size is outlying.]</p> <p>[Select other paper or zoom ratio.]</p>	An appropriate zoom ratio cannot be selected with the “Auto” Zoom setting selected.	Specify a zoom ratio between 25% and 400%.
<p><b>[Place Original on Glass]</b></p> <p>[Unable to scan from ADF with this zoom ratio.]</p>	The selected zoom ratio (200% or more) cannot be used to scan from the ADF.	Place the document on the original glass.
<p><b>[Duplex Copy Disabled]</b></p> <p>[Duplex copy disabled. Cancel it or select]</p> <p>[;A5-Legal/Plain Paper/Thick 1-2]</p>	The selected paper type and size cannot be used with duplex (double-sided) printing.	Cancel duplex (double-sided) printing, or change the paper type and size settings.

<b>Message</b>	<b>Cause</b>	<b>Solution</b>
<b>[Memory Full (Scan)]</b> [Insufficient memory.] [The job is cancelled.]	The memory capacity is insufficient. Otherwise, the SSD storage area is insufficient.	Cancel the job.
<b>[HDD Capacity Over]</b> [Insufficient HDD capacity.] [Delete unnecessary file.] [The job is cancelled.]	There is not enough space available on the hard disk.	Delete any unnecessary files. Cancel the job.
<b>[Document Registration Limit Over]</b> [Saved documents in folder reached limit.] [The job is cancelled.]	The number of image files on the hard disk has reached the maximum possible.	Cancel the job.
<b>[Connection Failed]</b> [Check if the destination is correct.] [The job is cancelled.]	The machine failed to connect to the FTP server.	Wait a while. The error is canceled.
<b>[Error Occurred during Writing]</b> [Check whether it is write-protected or out of space.]	The machine failed to write data to the USB memory device.	Cancel the job.
<b>[Scan TX Failed]</b> [Scan TX failed.] [Job is cancelled.]	The scan transmission failed. (Does not appear with a broadcast transmission.)	Wait a while. The error is canceled.
<b>[Counter reached its limit.]</b> [The counter has reached its maximum allowance.] [Please delete the job.]	The counter has reached the upper limit.	Delete the job.

Message	Cause	Solution
<p><b>[I-Fax RX failed]</b></p> <p>[Failed to complete the job due to an error while I-FAX RX.]</p> <p>[Check the log.]</p>	<p>The job did not end normally because an error occurred during I-FAX RX.</p>	<p>Check the log.</p>
<p><b>[I-Fax TX failed]</b></p> <p>[I-FAX TX failed due to error.]</p> <p>[Redial will be attempted after predetermined time progress.]</p>	<p>The job did not end normally because an error occurred during I-FAX TX.</p>	<p>A document is sent again after the specified time period has lapsed.</p>



## Service messages

These messages indicate a more serious problem that can only be corrected by a service representative. If one of these messages appears, turn the machine off, then on again. If the problem persists, contact your local vendor or authorized service provider.

Message	Cause	Solution
<b>[Service Call]</b> [Error occurred. Power OFF and ON, or contact Service with Trouble Code;xxxx]	An error has been detected with the item indicated by "xxxx" in the service message.	Restart the machine. This often clears the service message, and machine operation can resume.  If the problem persists, contact the service representative.



*Installing  
Accessories* **14**



# Introduction

## Note

---

**Use of accessories not manufactured or supported by manufacturer will void your warranty.**

---



*For details of accessories, visit our web site*

<b>Lower Feeder Unit (Tray 3/Tray 4)</b>	500-sheet tray included
<b>Working Table WT-P01</b>	Provides an area to temporarily place an original or install an authentication device.

# Lower Feeder Unit PF-P08

You can install up to one optional lower feeder unit PF-P08 (Tray 3/4). The lower feeder unit PF-P08 increases your machine's media feed capacity by 500 sheets.

## Kit Contents

- Lower feeder unit with a tray (500-sheet capacity)

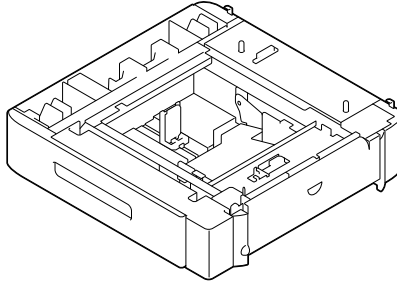

# Installing a Lower Feeder Unit PF-P08

## Note

---

Since consumables are installed in the machine, be sure to keep the printer level when moving it in order to prevent accidental spills.

---

- 1 Turn off the machine and disconnect the power cord and interface cables.

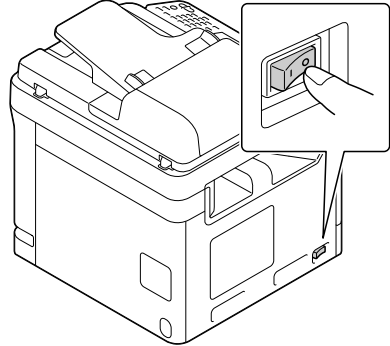

- 2 Prepare the lower feeder unit.



*Be sure to place the lower feeder unit on a level surface.*

- 3 Open the right side cover of the lower feeder unit.

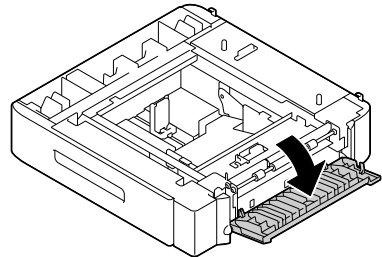

*The right side cover of the lower feeder must be opened before the feeder can be installed onto the machine.*

- 4 With another person's help, place the machine on top of the lower feeder unit, making sure that the positioning pins on the lower feeder unit correctly fit into the holes on the bottom of the machine.

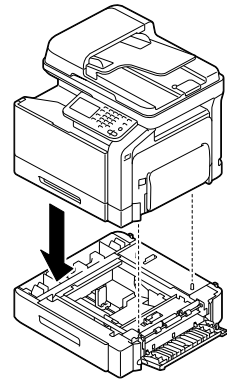

## **WARNING!**

**This machine weighs approximately 39 kg (86 lbs) when it is fully loaded with consumables. The machine must be lifted by two people.**

- 5 Close the right side cover of the lower feeder unit.

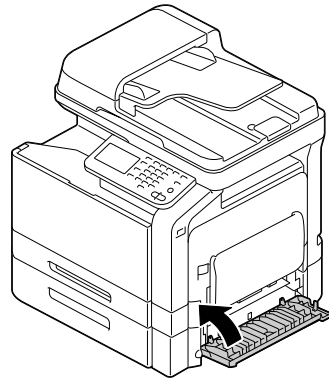

- 6 Reconnect all interface cables.

- 7 Reconnect the power cord, and turn on the machine.

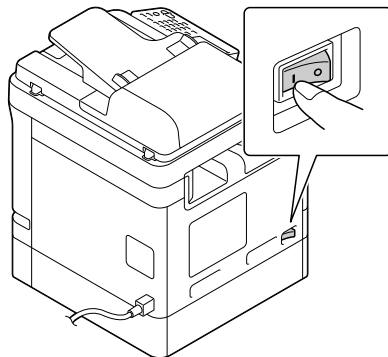

- 8 Declare Paper Source Unit 3/4 in the Windows printer driver [Properties]/ [Configure] tab.

## Working Table WT-P01

Provides an area to temporarily place an original or other materials. This is also used when the authentication device is installed.

### Kit Contents

a—Working table

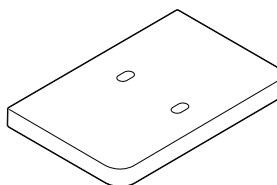

b—Mounting plate

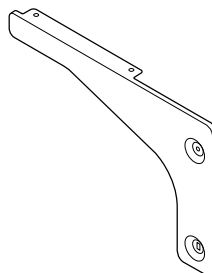



c—Four screws

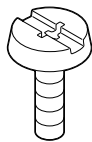

d—Two screws

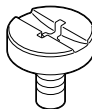

e—Two clamps

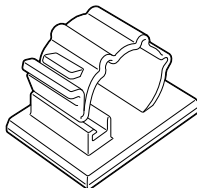

*Use this part when installing the Authentication Device (IC card type).  
Store the part in a safe place for future use.*

## Installing a Working Table WT-P01

- 1 Using a coin, turn the screws (c) to install the mounting plate.

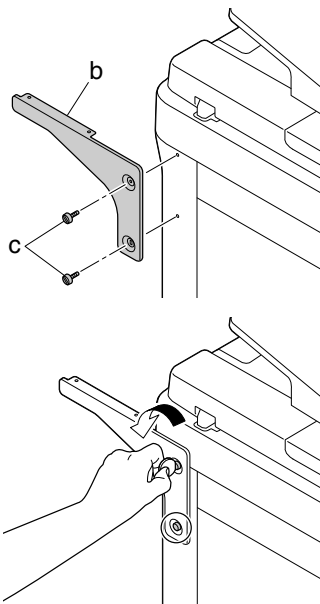

- 2** Tighten the screws (c) temporarily.

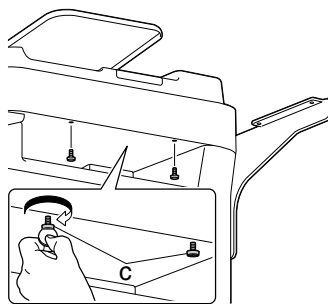

- 3** Install the working table.

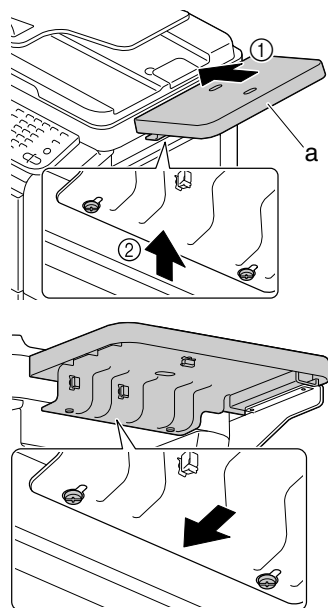

- 4** Using a coin, tighten the screws (c).

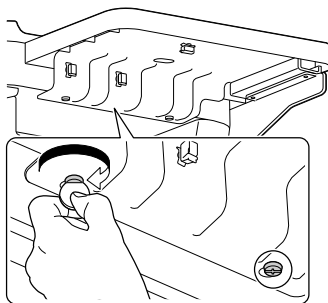

- 5** Using a coin, tighten the screws (d).

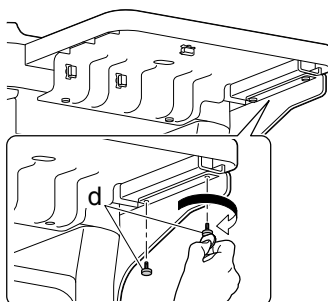



*Authentication  
device (IC card  
type)*

15



# Using authentication device (IC card type)

The authentication device (IC card type) is an IC card authentication system that reads the IC card to perform personal authentication. Using this system, you can perform authentication with an IC card to log in to this machine or execute a print job when User Authentication is enabled in this machine.

To use the authentication device, first register the card ID of the user in this machine. The registered user, who is authenticated with the card ID, can log in to this machine or execute a print job. This section explains how to configure the required settings in this machine, register users, and log in to this machine with authentication.



*Do not disconnect the USB cable while using the authentication device. Doing so may cause the system to become unstable.*



*Do not leave the IC card within 40 mm of the card reader.*

## Configuring this machine

User authentication settings must be configured with MFP authentication on this machine.

Configure the user authentication settings using Web Connection.



*For details on using Web Connection, refer to "Reference Guide".*

- 1 In Administrator mode of Web Connection, click [Security] tab - [Authentication] - [General Settings].
- 2 In [User Authentication], select [Device].
- 3 Click [Apply] to save the settings.
- 4 In the [General Settings] page of [Authentication Device Settings], select [Authentication Type] and [IC Card Type].
  - In [IC Card Type], specify the required IC card type.
  - For [Authentication Type], specify how to log in to this machine after registration.
    - [Card Authentication]: Allows the user to log in by simply placing the IC card.
    - [Card Authentication + Password]: Allows the user to log in by placing the IC card and entering the password.
  - For details on how to log in to this machine, refer to "Logging in to this machine" on page 15-6.
- 5 Click [Apply] to save the settings

- If the card function setting page appears, specify the necessary settings.

## 6 Exit Web Connection.

Then, proceed with the user registration.

# Registering a user

Register a user using Data Administrator. The following two methods can be used.

- Connect the authentication device to your computer, and use Data Administrator to register the target user and card at a time.
- Connect the authentication device to this machine, and associate the user, who has been registered using Data Administrator, with an IC card.

## Registering a user using Data Administrator

To use Data Administrator, configure this machine, and set up Data Administrator. For setup, install the IC Card Driver (USB-Driver) of the authentication device, and then install Data Administrator IC Card Plugin.



*Before setup, install Data Administrator V4.0 or later in your computer. For the Data Administrator operating environment and installation procedure, refer to the Data Administrator User's Guide.*

## Checking the version of the installed Data Administrator

- 1 From the [Help] menu of Data Administrator, select [Version Information].



*This software cannot be used if the version is "3.x". Install "4.x". If Data Administrator V3.x is installed, it is removed when V4.x is installed.*

- 2 Click [Plug-in version].

- 3 In [Plug-in information list], confirm the plugin version of Data Administrator.

- This software is available if the plugin version is "4.x".

## Setup

- 1 Turn the Main Power Switch of this machine off, and disconnect the authentication device from this machine.

- 2 Install IC Card Driver (USB-Driver).  
Connect the authentication device to the USB port of your computer.  
The [Found New Hardware] dialog box appears.
- 3 Select [Locate and install driver software (recommended)].
- 4 Insert the application CD-ROM provided with the authentication device into the CD-ROM drive of the computer.
- 5 Click the [Browse my computer for driver software (advanced)].
- 6 Check that the driver's search location is the application CD-ROM, and then click [Next].
  - When the driver's search location is not the application CD-ROM, click [Browse]. Select the IC Card Driver (USB-Driver) folder in the CD-ROM, and click [OK].
  - Installation starts.

7 Click [Close].

Installation of the IC Card Driver (USB-Driver) is completed.

- 8 Install Data Administrator IC Card Plugin.  
Open the IC\_Card\_Plugin folder on the application CD-ROM, and then click setup.exe.

- 9 Select a language, and then click [OK].

The installation program starts.

- 10 Follow the on-screen instructions to proceed with the installation.
- 11 Click [Next].
- 12 Select [I accept the terms in the license agreement], and then click [Next].
- 13 Click [Install].
- 14 Click [Finish].

Installation of the Data Administrator IC Card Plugin is completed, which completes the setup.

## User registration

To register a user with Data Administrator, the computer and this machine must be connected via network.

Also, to proceed to register a card with Data Administrator, the authentication device must be connected to the USB port of the computer.

When registering a user, you can only enter the card ID and associate the user with card using the authentication device unit connected to this machine.

- 1 Turn the main power switch on.



**2** To register a user and card with Data Administrator at a time, connect the authentication device to the USB port of the computer that contains Data Administrator.



*Do not connect another USB device to the same port as for the authentication device. Doing so reduces the USB power supply, resulting in an operation failure.*



*To use the USB hub, be sure to connect the self-power USB hub that supplies 500 mA or more.*



*Restart the procedure 5 or more seconds after connecting the authentication device.*

**3** Data Administrator starts, and device information of this machine is imported.

The Device Information window appears.

- For details on how to import device information, refer to the Data Administrator User's Guide.

**4** In Select Function, select [Authentication settings] - [User authentication settings], and then click [Add].

**5** Select the desired template, and then click [OK].

The User settings window appears.

**6** Enter the user name and password, and select the [IC card authentication] tab.

- Enter the E-mail address and other information as required.

**7** Place the IC card on the authentication device, and click [Start reading].

- To skip the card registration with Data Administrator, but to associate the card with user using the authentication device connected to this machine, select [Input the card ID directly] and enter the card ID number corresponding to the registered user.

**8** Click [OK].

- Repeat steps 4 to 7 to register all users.

**9** Click [Export to the device]

- Select the user name and click [Edit] to change the registered data.

**10** Click [Write].

- Data Administrator provides the batch copy function that batch-configures the registered user data in multiple machines with the authentication device enabled.

The registered user data is configured in this machine.

**11** Click [OK]

- 12 If the authentication device is already connected to the computer, remove it, turn the main power of this machine off, and then connect the authentication device to this machine.



*To turn the power switch of this machine off and on, first turn the main power switch off, and then turn it on after 10 or more seconds has elapsed. Not doing so may result in an operation failure.*



*When connecting or disconnecting the USB cable, hold the plug. Otherwise, the cable may be damaged.*

If you only enter the card ID when registering a user, associate the user with card using the authentication device connected to this machine.

## Associating the user with card using authentication device

When a user and card ID have been registered using Data Administrator, the user must be associated with the card in the Administrator Settings of the machine.

- 1 Press [Utility/Counter] key on the control panel of this machine to switch to the [Admin Settings] screen.
- 2 Press [Authentication Setting].
- 3 Press [Card Authentication].
- 4 Select a user to be registered, and press [OK].
  - Press [All] to display all users. Press [Search] to extract target users with search characters.
- 5 Press [Edit].
  - Press [Delete] to cancel the registration when IC card information is already registered.
- 6 Place the IC card on the authentication device, and press [OK].
  - This associates the user with the IC card and registers the IC card for the user.

## Logging in to this machine

The following explains how to log in to this machine with IC card authentication.

- To perform IC card authentication, register the information recorded in the IC card in advance.

- If an authentication failure recurs, the problem may be due to incorrect registration of IC card information. Register IC card information again.
- When [Card Authentication] is specified for [Authentication Type], a registered user is authenticated by simply placing the IC card. When [Card Authentication + Password] is specified, a registered user is authenticated by placing the IC card and entering the password.
- Press [User Name] and [Password] to log in by entering the user name and the password, without using the authentication device.
- IC card authentication cannot be performed while the machine is in Power Save mode. After pressing the [Power Save] key to cancel Power Save mode, place the IC card on the authentication device and complete the authentication procedure.

## When [Card Authentication] is enabled

- 1 Press [Card Authentication].



*When using the ID & Print function with IC card authentication, select [Begin Printing] or [Access Basic Screen] as necessary. For details on the ID & Print function, refer to "ID & Print" on page 6-4.*

- 2 Place the IC card on the authentication device.

## When [Card Authentication + Password] is enabled

- 1 Press [Card Authentication].



*When using the ID & Print function with IC card authentication, select [Begin Printing] or [Access Basic Screen] as necessary. For details on the ID & Print function, refer to "ID & Print" on page 6-4.*

- 2 Place the IC card on the authentication device.
- 3 Press [Password] and enter the password.
- 4 Press [Login].





*Appendix* **A**



# Technical specifications

Type	Desktop integrated flatbed ADF printer		
Document holder	Stationary (unit scanning)		
Photoconductor	OPC		
Luminous source	CCFL Dual		
Printing system	Semiconductor laser beam scanning + dry-type electrophotographic method		
Developing system	Dry mono-component SMT developing system		
Fusing system	Lower free belt fusing system		
Resolution	Scanning	600 dpi × 600 dpi (standard), 600 dpi × 1200 dpi (max.), 600 dpi × 300 dpi (when using ADF)	
	Printing	600 dpi×600 dpi	
Document	Type	Sheets, books, and other three-dimensional objects	
	Size	Maximum Legal	
	Weight	Maximum 3 kg	
First print	Black and white/color: 12.9 seconds or less (with plain A4 paper), 12.8 seconds or less (with plain Letter paper)		
First copy	Black and white	10.1 seconds or less (with plain Letter/A4 paper)	
	Color	12 seconds or less (with plain Letter/A4 paper)	
Print speed/copy speed	Simplex (single-sided)	Plain paper	A4: 30.0 pages/minute (black and white/color) Letter: 31.6 pages/minute (black and white/color)
		Thick paper	A4: 15.0 pages/minute (black and white/color) Letter: 15.8 pages/minute (black and white/color)
	Duplex (double-sided)	Plain paper	A4: 30.0 sides/minute (black and white/color) Letter: 31.6 sides/minute (black and white/color)

Warm-up Time	Time until the machine is ready to begin printing after being turned on (at room temperature (23°C)) 120 V: Avg. 45 seconds 220 V: Avg. 45 seconds 240 V: Avg. 45 seconds	
Paper sizes	Tray 1 (manual feed tray)/ Tray 2	Paper width <sup>*1</sup> : 92 to 216 mm Paper length: 148 to 356 mm <sup>*1</sup> Envelopes with a width of 220 mm can be printed from Tray 1 (manual feed tray).
	Tray 3/ Tray4 (optional)	A4, B5, Executive, Letter, Government Legal, Legal
Paper types	<ul style="list-style-type: none"> <li>■ Plain paper (60 to 90 g/m<sup>2</sup>)</li> <li>■ Recycled (60 to 90 g/m<sup>2</sup>)</li> <li>■ Envelopes</li> <li>■ Letterhead</li> <li>■ Label</li> <li>■ Thick 1 (91 to 150 g/m<sup>2</sup>)</li> <li>■ Thick 2 (151 to 210 g/m<sup>2</sup>)</li> <li>■ Postcard</li> <li>■ Glossy 1 (100 to 128 g/m<sup>2</sup>)</li> <li>■ Glossy 2 (129 to 158 g/m<sup>2</sup>)</li> <li>■ Single side only (60 to 90 g/m<sup>2</sup>)</li> <li>■ Special paper (60 to 90 g/m<sup>2</sup>)</li> </ul>	

Paper capacity	Tray 1 (manual feed tray)	Plain/Recycled/Single side only/Special paper: 100 sheets Envelope: 10 envelopes Label/Postcard/Thick 1/Thick 2/Glossy 1/Glossy 2/Letterhead: 20 sheets
	Tray 2	Plain/Recycled/Single side only/Special paper: 250 sheets Label/Postcard/Thick 1/Thick 2/Glossy 1/Glossy 2/Letterhead: 20 sheets
	Tray 3/ Tray 4 (optional)	Plain/Recycled/Single side only/Special paper: 500 sheets
Image loss width	Printing	Leading edge/trailing edge/right edge/left edge: 4.2 mm or less
	Copying	Leading edge/trailing edge/right edge/left edge: 4.0 mm or less
Output capacity	250 sheets	
Operating temperature	10 to 30°C (50 to 86°F)  <i>Fluctuations of no more than 10°C (18°F) within an hour.</i>	
Operating humidity	15 to 85%  <i>Fluctuations of no more than 10% within an hour.</i>	
Power supply	120 V, 60 Hz 220 to 240 V, 50 to 60 Hz	
Power consumption	120 V: 1200 W or less 220 to 240 V: 1300 W or less Power Save mode: 34 W or less	
Amperage	120 V: 10.9 A or less 220 to 240 V: 4.8 A or less	
Acoustic Noise	Printing: 55 dB or less Copying: 57 dB or less Standby: 39 dB or less	



External dimensions	<p>Height: 550 mm (21.7")  Width: 530 mm (20.9")  Depth: 508 mm (20")</p>  <i>Excluding some protruding parts and the manual feed tray.</i>
Weight	<p>Approximately 34.6 kg (76.3 lb) (without consumables)  Approximately 39.0 kg (86.0 lb) (with consumables)</p>
Interface	USB 2.0 (High Speed) compliant, 10Base-T/100Base-TX/1000Base-T Ethernet, Host USB (USB device printing)
Standard memory	1536 MB
Hard disk	120 GB
Machine life	Maximum 400,000 pages and no more than 5 years

# Consumable Life Expectancy Chart

## User-Replaceable

Item	Average Life Expectancy
Toner cartridge	<b>Standard in-box Cartridge:</b> 6,000 pages or more (continuous) <b>Replacement Cartridge (High-Capacity):</b> 6,000 pages or more (continuous) Declared yield value in accordance with ISO/IEC 19798.  <i>The toner cartridge life will be shorter when using intermittent printing.</i>
Imaging unit	30,000 pages (continuous) 20,000 pages (2 pages per job)
Waste toner bottle	36,000 pages (monochrome) (continuous) 9,000 pages (full color) (continuous) Declared yield value in accordance with ISO/IEC 19798.
Transfer roller	100,000 pages
Transfer belt unit	100,000 pages (continuous)
Fuser unit	100,000 pages (continuous)



*The values shown above indicate the number of pages for simplex printing using A4/Letter-size media with 5% coverage. The actual life may differ (be shorter) depending on the printing conditions (coverage, paper size, etc.), differences in the printing method, such as continuous printing or intermittent printing (when print jobs of one page are often printed), or the type of paper used, for example, thick paper. In addition, the life will be affected by the temperature and humidity of the operating environment.*



*Whether printing in color or black and white, color printers consume a small amount of each toner during the initialization operation when the machine is turned on or off and during automatic adjustments to maintain print quality. Even if an operating error occurred during black-and-white printing, color toner is consumed and may need to be replaced.*

## Service-Replaceable

Item	Average Life Expectancy
Media feed roller	300,000 pages

# Text input

The procedure for using the keyboard screen is described below.

## Entering text

In the keyboard screen, press the character that you want to enter.

- To enter uppercase letters, press [↑].
- To enter symbols, press [!#?/].
- To enter special characters, such as accented characters, press [äü].
- To delete the character to the right of the cursor, press [Delete].
- To move the cursor, press [←] or [→].



*Numbers can also be typed in with the keypad in the control panel.*



*To clear all entered text, press the [C] key.*

# Our Concern for Environmental Protection



As an ENERGY STAR® Partner, we have determined that this machine meets the ENERGY STAR Guidelines for energy efficiency.

## **What is an ENERGY STAR product?**

An ENERGY STAR product has a special feature that allows it to automatically switch to a “low-power mode” after a period of inactivity. An ENERGY STAR product uses energy more efficiently, saves you money on utility bills and helps protect the environment.



---

# Index

---

## Numerics

**10Base-T/100Base-TX/1000Base-T Ethernet Interface port** ..... 1-4

## A

**Accessibility** ..... 3-2  
**Account track** ..... 2-15, 2-16  
**Address Book** ..... 10-34  
**Address Registration** ..... 3-8, 10-35  
**ADF** ..... 1-4  
**ADF feed cover** ..... 1-4  
**Admin Settings** ..... 3-21  
    Address Registration ..... 3-43  
    Administrator Registration ..... 3-43  
    Authentication Setting ..... 3-44  
    Copy Settings ..... 3-48  
    Ethernet ..... 3-45  
    External Memory Print ..... 3-48  
    Fax Settings ..... 3-63

    Folder Settings ..... 3-69  
    HDD Format ..... 3-77  
    Job Timeout ..... 3-48  
    Machine Settings ..... 3-41  
    Maintenance Menu ..... 3-63  
    Paper Empty ..... 3-78  
    Print Settings ..... 3-49  
    Restore Defaults ..... 3-77  
    Security Settings ..... 3-70

**Associating the user with card using authentication device** ..... 15-15

## C

**Configuring this machine** ..... 15-2

### Consumables

    Backup Battery ..... 11-30  
    Fuser Unit ..... 11-33  
    Imaging Unit ..... 11-9  
    Toner Cartridge ..... 11-2  
    Transfer Belt Unit ..... 11-22

Transfer Roller .....	11-20
Waste Toner Bottle .....	11-17
<b>Control panel</b> .....	1-4, 2-2
<b>Copy mode</b> .....	7-2
Color Mode .....	7-9
Density .....	7-8
Duplex/Combine .....	7-7
Finishing .....	7-10
ID Copy .....	7-13
Image Quality .....	7-15
Original Size .....	7-4
Original Type .....	7-9
Paper .....	7-5
Paper Margin .....	7-14
Proof Copy .....	7-10
Separate Scan .....	7-11
Zoom .....	7-6

## D

<b>Document feed tray</b> .....	1-4
<b>Document guide</b> .....	1-4
<b>Document output tray</b> .....	1-4
<b>Document stopper</b> .....	1-4

## E

<b>External Memory</b> .....	6-3
------------------------------	-----

## F

<b>Front cover</b> .....	1-4
<b>Fuser unit</b> .....	1-4

## G

<b>Group</b> .....	10-34
--------------------	-------

## I

<b>Imaging unit</b> .....	1-4
<b>Interrupt</b> .....	8-2

## L

<b>LINE (telephone line) jack</b> .....	1-4
<b>Loading Media</b> .....	4-14
<b>Logging in to this machine</b> .....	15-15

<b>Lower feeder unit</b> .....	1-4, 14-3
--------------------------------	-----------

## M

<b>Maintenance</b> .....	12-2
--------------------------	------

### Media

Clearing misfeeds .....	13-6
Loading .....	4-14
Path .....	13-5
Preventing misfeeds .....	13-4

### Media Misfeed

ADF .....	13-13
Duplex .....	13-15
Fuser Unit .....	13-16
Transfer Roller .....	13-20
Tray 1 .....	13-20
Tray 2 .....	13-7
Tray 3/4 .....	13-11

<b>Media Path</b> .....	13-5
-------------------------	------

### Messages

Error messages .....	13-39
Operator messages .....	13-41
Service messages .....	13-47
Status messages .....	13-38
Warning messages .....	13-39

<b>Meter Count</b> .....	3-7
--------------------------	-----

<b>Misfeed problems</b> .....	13-23
-------------------------------	-------

<b>Mode Memory</b> .....	8-3
--------------------------	-----

## O

<b>Original cover pad</b> .....	1-4
---------------------------------	-----

<b>Original glass</b> .....	1-4
-----------------------------	-----

### Original Media

Loading .....	4-36
---------------	------

<b>Output tray</b> .....	1-4, 4-32
--------------------------	-----------

## P

<b>Page Margins</b> .....	4-13
---------------------------	------

<b>Part Names</b> .....	1-4
-------------------------	-----

<b>Power connection</b> .....	1-4
-------------------------------	-----

<b>Power switch</b> .....	1-4
---------------------------	-----

<b>Print Media</b> .....	4-2
--------------------------	-----

Envelopes .....	4-13
-----------------	------

Storage .....	4-33
---------------	------



<b>Print media type</b>	
Envelope .....	4-6
Glossy Media .....	4-9
Label .....	4-7
Letterhead .....	4-8
Plain Paper (Recycled Paper) .....	4-4
Postcard .....	4-8
Single Side Only .....	4-10
Special Paper .....	4-11
Thick Stock .....	4-5
<b>Print quality</b> .....	13-31
<b>Print Setting</b>	
Copy Settings .....	3-15
Fax Settings .....	3-20
Machine Settings .....	3-13
Print Settings .....	3-17
Scan Settings .....	3-16
<b>Printable Area</b> .....	4-12
<b>Printer driver</b>	
Advanced Tab .....	5-7
Basic Tab .....	5-8
Cover Mode Tab .....	5-9
Displaying .....	5-5
Layout Tab .....	5-9
My Tab .....	5-8
Other Tab .....	5-11
Quality Tab .....	5-10
Uninstalling .....	5-4
Watermark/Overlay Tab .....	5-9
<b>Program</b> .....	10-34
<b>Program Address</b> .....	10-37
<b>Proof Print</b> .....	6-2

## R

<b>Rear cover</b> .....	1-4
<b>Registering a user</b> .....	15-4
<b>Right door</b> .....	1-4

## S

<b>Scan mode</b> .....	9-2
<b>Scan to E-mail mode</b> .....	10-3
Background/Density .....	10-8
Binary Division .....	10-12
Color Mode .....	10-7
E-mail .....	10-13

E-mail Encryption .....	10-12
File Setting .....	10-9, 10-10
Original Settings .....	10-5, 10-6
Original Size .....	10-5
Original Type .....	10-7
Resolution .....	10-8
Send Use Signature .....	10-12
Simplex/Duplex .....	10-4
<b>Scan to Folder mode</b> .....	10-18
Background/Density .....	10-23
Color Mode .....	10-22
File Setting .....	10-24, 10-25
FTP .....	10-29
HDD .....	10-31
Original Settings .....	10-21, 10-22
Original Size .....	10-20
Original Type .....	10-23
PC(SMB) .....	10-29
Resolution .....	10-24
Simplex/Duplex .....	10-20
URL Notification .....	10-27
URL Notification Destination .....	10-27
USB Memory .....	10-30
Web Service Settings .....	10-32
WebDAV .....	10-30
<b>Scanner lock lever</b> .....	1-4
<b>Scanner unit</b> .....	1-4
<b>Service messages</b> .....	13-47
<b>System Requirements</b> .....	1-13

## T

<b>TEL (telephone) jack</b> .....	1-4
<b>Text input</b> .....	A-8
<b>Toner cartridge</b> .....	1-4
<b>Touch panel</b> .....	2-5
<b>Transfer belt unit</b> .....	1-4
<b>Transfer roller</b> .....	1-4
<b>Tray 1 (Manual feed tray)</b> .....	1-4
<b>Tray 2</b> .....	1-4
<b>Tray 3</b> .....	1-4
<b>Tray 4</b> .....	1-4
<b>Troubleshooting</b> .....	13-1
Media Misfeeds .....	13-23
Status, error and service messages .....	13-38

**TWAIN Driver** .....9-3, 9-8

## **U**

**USB HOST port** ..... 1-4

**USB port** ..... 1-4

**User authentication** .....2-15

    Device authentication .....2-15

    External server authentication  
    .....2-15

**User Settings** .....3-10

**Using authentication device  
(IC card type)** ..... 15-2

**Utility Setting** .....3-1

## **W**

**Waste toner bottle** ..... 1-4

**When [Card Authentication +  
Password] is enabled** ..... 15-16

**When [Card Authentication] is  
enabled** ..... 15-16

**WIA Driver** .....9-7

**Working Table** ..... 1-4, 14-6